

# Owner's Manual

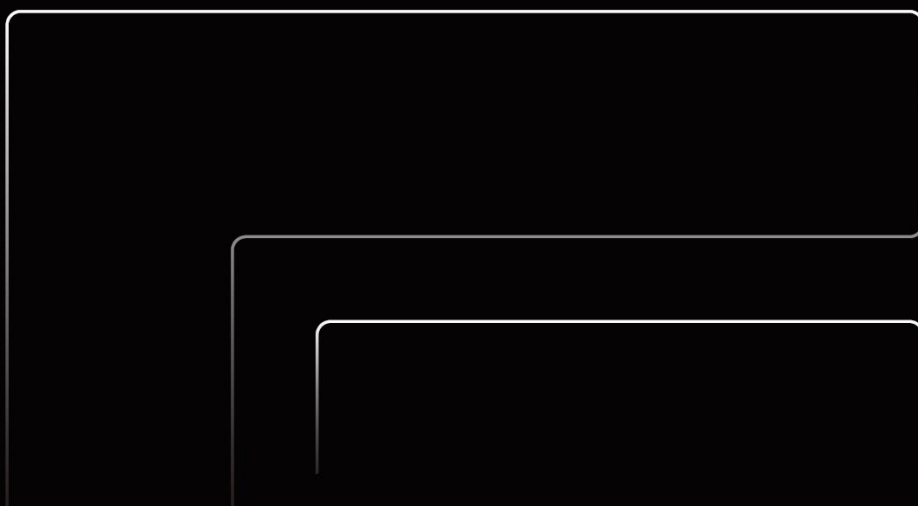

# Table of Contents

1. Introduction .....	1
1.1 Introduction .....	1
1.1.1 Introduction .....	1
2. Manual description .....	3
2.1. Manual description .....	3
2.1.1. Manual description .....	3
3. Picture index .....	4
3.1 Exterior .....	4
3.1.1 Exterior .....	4
3.2 Interior .....	6
3.2.1 Interior .....	6
4. Safety instructions .....	9
4.1 Instructions for safe use .....	9
4.1.1 Before driving .....	9
4.1.2 Safe driving .....	9
4.1.3 Seat belt .....	11
4.1.4 Airbag .....	16
4.1.5 High voltage system .....	29
4.1.6 Precautions for waste gas .....	32
4.2 Child safety .....	33
4.2.1 Child safety information .....	33
4.2.2 Child safety seat .....	34
4.2.3 Installation of child safety seat .....	40
4.2.4 Child safety lock .....	43

4.3 Range extender system .....	45
4.3.1 Range extending system feature .....	45
4.3.2 Precautions for range extending .....	46
4.4 Anti-theft system .....	47
4.4.1 Anti-theft system .....	47
5. Information display .....	48
5.1 Instrument and central control system .....	48
5.1.1 Instrument screen .....	48
5.1.2 Central control screen .....	51
6. Operation .....	55
6.1 Key information .....	55
6.1.1 Key .....	55
6.1.2 Remote key .....	55
6.1.3 Keyless entry and start system .....	57
6.2 Opening, closing and locking door .....	62
6.2.1 Doors .....	62
6.2.2 Trunk door .....	69
6.3 Seat adjustment .....	77
6.3.1 Front row seats .....	77
6.3.2 Second row seats .....	80
6.3.3 Third row seats .....	89
6.3.4 Headrest .....	91
6.4 Adjustment of steering wheel and rearview mirror .....	95
6.4.1 Steering wheel .....	95
6.4.2 Interior rearview mirror .....	100

6.4.3 Exterior rearview mirror	105
6.5 Memory function	109
6.5.1 Driver memory function	109
6.5.2 Driver welcome seat	110
6.6 Window and sunshade	111
6.6.1 Window	111
6.6.2 Sunshade	114
6.7 A/C system	118
6.7.1 Front A/C system	118
6.7.2 Rear A/C system	122
6.7.3 Steering wheel heating/seat heating and ventilation	126
6.8 Vehicle interior illumination light	129
6.8.1 Interior reading light control	129
6.8.2 Vanity lamp	131
6.8.3 Ambient light	131
6.8.4 Welcome light illumination	132
6.9 Storage device	133
6.9.1 Glove box	133
6.9.2 Storage box	134
6.9.3 Cup holder	142
6.9.4 Seat map pocket	146
6.9.5 Trunk equipment	147
6.9.6 Roof rack	150
6.10 Other onboard equipment	152
6.10.1 Sunshade	152
6.10.2 Vanity lamp	152



6.10.3 12V power socket	152
6.10.4 220V power socket	153
6.10.5 Wireless charging	155
6.10.6 USB power interface	157
6.10.7 Driving recorder	162
6.10.8 Microphone	163
6.10.9 Assist grip	163
6.10.10 Coat hook	164
<b>7. Driving</b>	<b>165</b>
7.1 Before driving	165
7.1.1 Driving vehicle	165
7.1.2 Cargo and luggage	166
7.1.3 Trailer towing	166
7.2 Driving specification	172
7.2.1 Power mode switching	172
7.2.2 Gearshift mechanism	173
7.2.3 Turn signal light control	175
7.2.4 Low-speed pedestrian warning sound	175
7.2.5 Special road condition	176
7.2.6 Tire pressure monitoring system (TPMS)	176
7.2.7 Electronically controlled adjustable suspension	177
7.2.8 Speed-sensitive variable electronic power steering	177
7.3. Driving essentials	177
7.3.1 Driving essentials for extended range vehicles	177
7.3.2 Driving essentials	180
7.3.3 Precautions for extended range vehicles	181

7.4 ROX Mode	182
7.4.1 ROX Mode	182
7.5 Operation of light and wiper	184
7.5.1 Exterior light switch	184
7.5.2 Adjust the low beam height	185
7.5.3 Automatic high beam	186
7.5.4 Automatic low beam	186
7.5.5 Brake light	186
7.5.6 Reverse light	186
7.5.7 Fog light switch	187
7.5.8 Windshield wiper and washer	187
7.5.9 Rear window wiper and washer	191
7.6 Driving assist system	191
7.6.1 Driver monitor system	191
7.6.2 Adaptive cruise control	192
7.6.3 Lane change assist	197
7.6.4 Rear collision Warning	198
7.6.5 Blind spot detection assist	201
7.6.6 Lane centering control	202
7.6.7 Front crossing traffic alert	209
7.6.8 Rear crossing traffic alert	210
7.6.9 Door open Warning	211
7.6.10 Around view monitoring	212
7.7 Brake system	215
7.7.1 Electronic handbrake (EPB)	215
7.7.2 Electronic stability program (ESP)	216

7.7.3 Anti-lock brake system (ABS) .....	216
7.7.4 Electronic brake-force distribution (EBD).....	217
7.7.5 Traction control system (TCS).....	217
7.7.6 Hydraulic brake assist (HBA).....	217
7.7.7 Roll motion intervention (RMI).....	218
7.7.8 Cornering stability control (CSC) .....	218
7.7.9 Dynamic parking brake (CDP) .....	218
7.7.10 Hill descent control (HDC) .....	219
7.7.11 Hill start assist (HHC) .....	219
7.7.12 Coordinated regenerative braking system (CRBS) .....	220
7.8 Fuel oil and charging .....	221
7.8.1 Refuel.....	221
7.8.2 Charging (Configuration 1) .....	226
7.8.3 Charging (Configuration 2) .....	235
7.8.4 External discharge (Configuration 1).....	244
7.8.5 External discharge (Configuration 2).....	246
7.8.6 Power battery .....	251
8 Maintenance and repair .....	253
8.1 Maintenance and repair .....	253
8.1.1 New car run-in .....	253
8.1.2 Vehicle cleaning .....	253
8.1.3 Vehicle maintenance .....	254
8.1.4 Anti-corrosion .....	255
8.2 Regular maintenance.....	256
8.2.1 Regular maintenance .....	256
8.3 Self-maintenance .....	257

8.3.1 Hood	257
8.3.2 Engine compartment	259
8.3.3 Battery	261
8.3.4 LIDAR	262
8.3.5 Tire	262
8.3.6 Tire pressure	265
8.3.7 Wheel	266
8.3.8 Air conditioning filter	266
8.3.9 Windshield wiper	266
8.3.10 Remote-control key battery	268
8.3.11 Check and replace the fuse	271
8.4 Vehicle long-term parking	271
8.4.1 Vehicle long-term parking	271
9 In case of fault	273
9.1 Measures to be taken in case of emergency	273
9.1.1 On-board tools	273
9.1.2 Hazard warning light	274
9.1.3 Reflective vest	275
9.1.4 Warning sign	276
9.1.5 Vehicle needs towing	276
9.1.6 Inflation pump	283
9.1.7 Tire changing operation	284
9.1.8 Power system fails to start	289
9.1.9 Battery level depleted	289
9.1.10 Vehicle overheating	289
9.1.11 In case of vehicle getting stuck	290

9.1.12 Emergency Call	291
9.2 Accident rescue	294
9.2.1 Appearance identification information	294
9.2.2 Rescue protection device	295
9.2.3 Emergency cut-off high voltage system	296
9.2.4 Vehicle fire rescue	297
9.2.5 Vehicle wading rescue	298
9.2.6 Battery leak rescue	298
9.2.7 Vehicle cutting area	298
10 Vehicle specification	303
10.1 Specification	303
10.1.1 Maintenance data (fuel, oil, etc.)	303
10.2 Main dimension parameters of vehicle	304
10.2.1 Front and back of vehicle	304
10.2.2 Vehicle side	306
10.3 Vehicle technical performance parameters	308
10.3.1 Vehicle mass parameters	308
10.3.2 Power parameter	308
10.3.3 Energy economy parameter	308
10.3.4 Vehicle model	308
10.3.5 Drive type	308
10.4 Assembly technical parameters	309
10.4.1 Range extender (engine) specifications and parameter	309
10.4.2 Tire and hub parameters	309
10.4.3 Four-wheel alignment	309
10.4.4 Drive motor performance parameters	310

10.4.5 Power battery parameter	310
10.4.6 Brake system parameters	310
10.5 Vehicle identification information	312
10.5.1 Vehicle identification number (VIN)	312
10.5.2 Range extender (engine) ID code	313
10.5.3 Drive motor identification code	314
10.5.4 Microwave window	316
10.5.5 Ex-work nameplate	317
10.5.6 Diagnostic interface	318
10.5.7 Warning and indication label	319
11 Warranty Manual	320
11.1 Warranty scope	320
11.1.1 Warranty scope	320
11.2 Warranty period	320
11.2.1 Vehicle Warranty period of whole vehicle	320
11.2.2 Special explanation on the warranty period	321
11.3 Warranty disclaimer	321
11.3.1 Warranty disclaimer	321
12 Abbreviations and terminology	323
12.1 Abbreviations and terminology	323
12.1.1 Abbreviations and terminology	323

## 1.1 Introduction

### 1.1.1 Introduction

Dear ROX owner,

Thank you for choosing ROX 01.

Please read this manual carefully before driving your ROX 01. Through this manual, you will fully understand the technical features and operation information of the vehicle. ROX reserves the right to change the contents of this manual at all times. Your vehicle may vary depending on the version or manufacture date.

This manual explains the use of the vehicle in the form of text and schematic diagram. In general, both are consistent for the use of the vehicle. If you have any inconsistent in understanding, you can operate following the schematic diagram. Nevertheless, the schematic diagram diagrams are for reference only. If it is inconsistent with the actual object, the latter shall prevail.

Please strictly follow the warning information used in this manual, which will help you use your vehicle more safely. Incorrect operation of the vehicle may cause personal injury to you or others, or cause damage to the vehicle or property loss. ROX shall not be held responsible for it therefrom.

We wish you a safe and enjoyable drive. ROX

#### I. Accessory, part and modification

For parts to be replaced, it is strongly recommended to use the original parts or approved accessories of ROX. For any non-original parts or accessories not approved by ROX, whether for replacement or installation, ROX neither bears any liability nor provides any guarantee for it. Moreover, vehicle damage and performance problems caused by the use of non-original or non-approved ROX parts are not covered by the warranty.

Improper modification of the vehicle or installation of unapproved accessories may affect the maneuverability, safety or durability of the vehicle, and may also violate laws and regulations. In addition, vehicle damage or performance problems caused by modification are not covered by the warranty.

#### II. When driving your vehicle

Be sure to abide by traffic regulations and road speed limits, and always keep in mind to drive safely.

Do not drive a vehicle when your reaction ability is reduced (drugs, alcohol and fatigue, for example, can impair your reaction ability).

Please drive carefully, and pay attention to the trends of other road traffic participants at any time, so as to respond in time to avoid accidents.

#### III. Scrapping

The airbags and seat belt pretensioner in the vehicle contain explosive chemicals. Scrapping your vehicle without removing the airbags and seat belt pretensioner may lead to an accident. Therefore, before scrapping your vehicle, be sure to have it dismantled and scrapped by a professional service shop or contact ROX Service Center.

#### IV. Environment protection

# 1. Introduction

Improper handling of used parts, waste engine oil and power batteries can lead to environmental pollution. Therefore, please consult ROX Service Center before scrapping your vehicle. If your vehicle requires exhaust gas testing, please contact ROX Service Center.

## V. Electromagnetic protection

The millimeter wave radar equipped with the vehicle works in the frequency range of 76-79 GHz, meeting the radio frequency technical requirements of the automobile radar. To protect the radio astronomy business working in the same frequency band, vehicles are not allowed to enter the relevant restricted areas. For details, please refer to the [2021] No. 181 document issued by the Ministry of Industry and Information Technology.

## VI. Precautions for driving assist function

The driving assist system of ROX 01 senses the surrounding environment through sensors such as cameras, millimeter-wave radar, ultrasonic radar, and LIDAR, and calculates and analyzes environmental information to achieve early warning of some dangerous scenes and vehicle control. Using assisted driving functions in suitable scenarios can alleviate driving fatigue and improve driving safety. However, the assisted driving system has limitations. For your driving safety, please carefully read the following content before using the assisted driving system:

- Adaptive cruise control:

After the adaptive cruise control function is activated, the system will actively control the vehicle's acceleration and deceleration, start adaptive cruise control at the current speed, or follow the vehicle in front and maintain a certain distance. The front camera of the vehicle can identify the main traffic participants on the road. But for vehicles that are close or quickly merging, as well as stationary vehicles or objects (such as cone barrels, water filled barriers, construction road signs, high-speed isolation belts, diversion signs, etc.), drivers need to be ready to take over at any time.

- Lane change assist:

The lane change assist function can assist the driver in actively merging with adjacent lanes. When using this function, the driver needs to confirm the safety of the surrounding traffic environment. In sharp bends or sections with high traffic flow, lane change assist function may be limited.

\* In addition to the above functions, ROX 01 also has other assisted driving functions. For more information on assisted driving functions, please refer to the electronic manual.



2.1. Manual description

2.1.1. Manual description

S/N	Instruction
1	Introduce the warnings. Failure to follow may lead to serious injury or even death.
2	Introduce tips to better understand the vehicle.
3	Introduce precautions. Failure to follow may lead to damage or malfunction of the vehicle or equipment.
4	Introduce environmental protection issues. Failure to follow may cause environmental pollution.

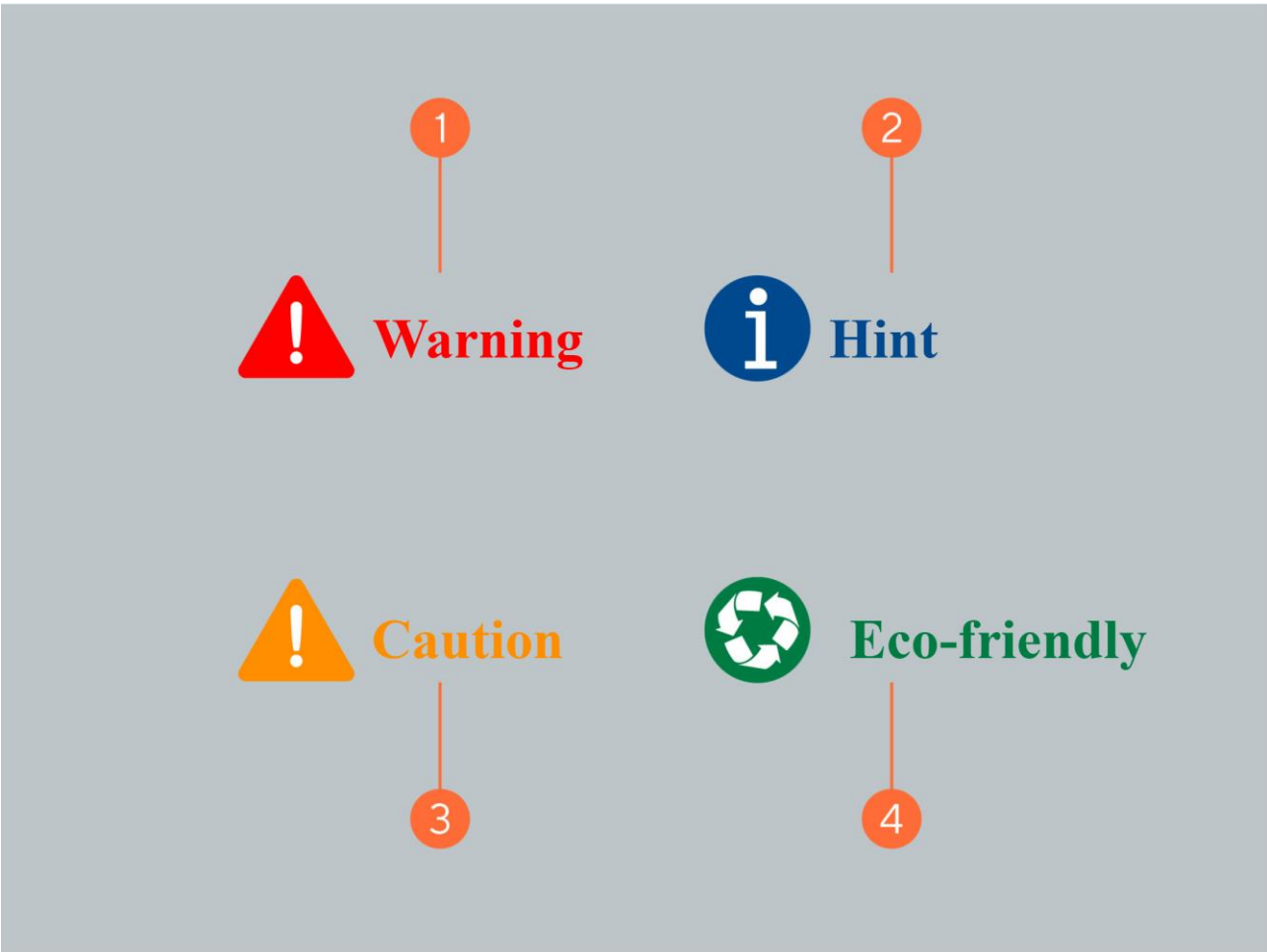

### 3. Picture index

#### 3.1 Exterior

##### 3.1.1 Exterior

S/N	Name	S/N	Name
1	Hood	2	Wiper
3	LIDAR	4	LIDAR
5	Door handle	6	Fuel filling port

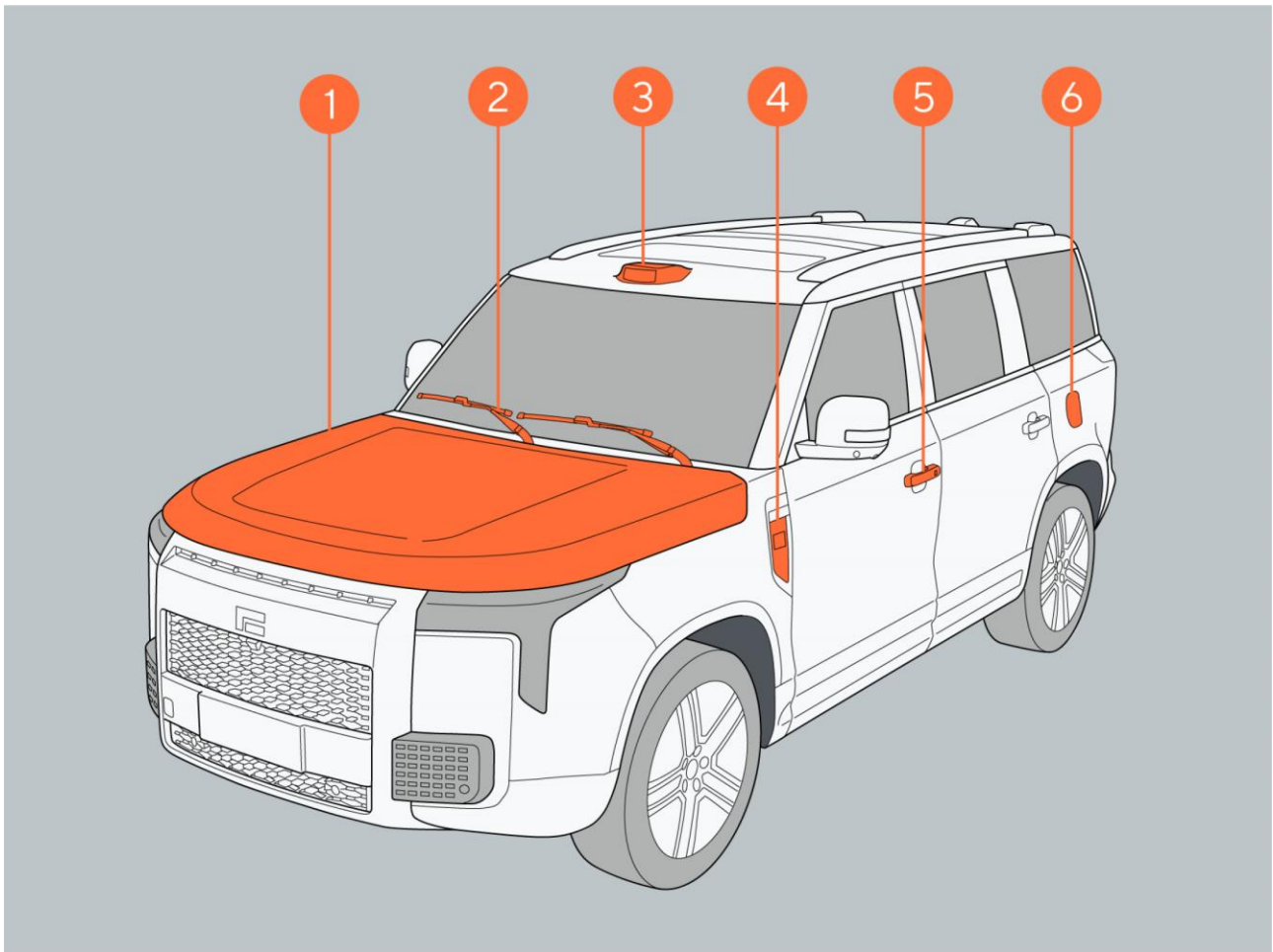

### 3. Picture index

S/N	Name	S/N	Name
1	Stream media rearview camera	2	High-position brake light
3	Rear wiper	4	Tailgate handle
5	Rear towing hook cover	6	Charging port lid

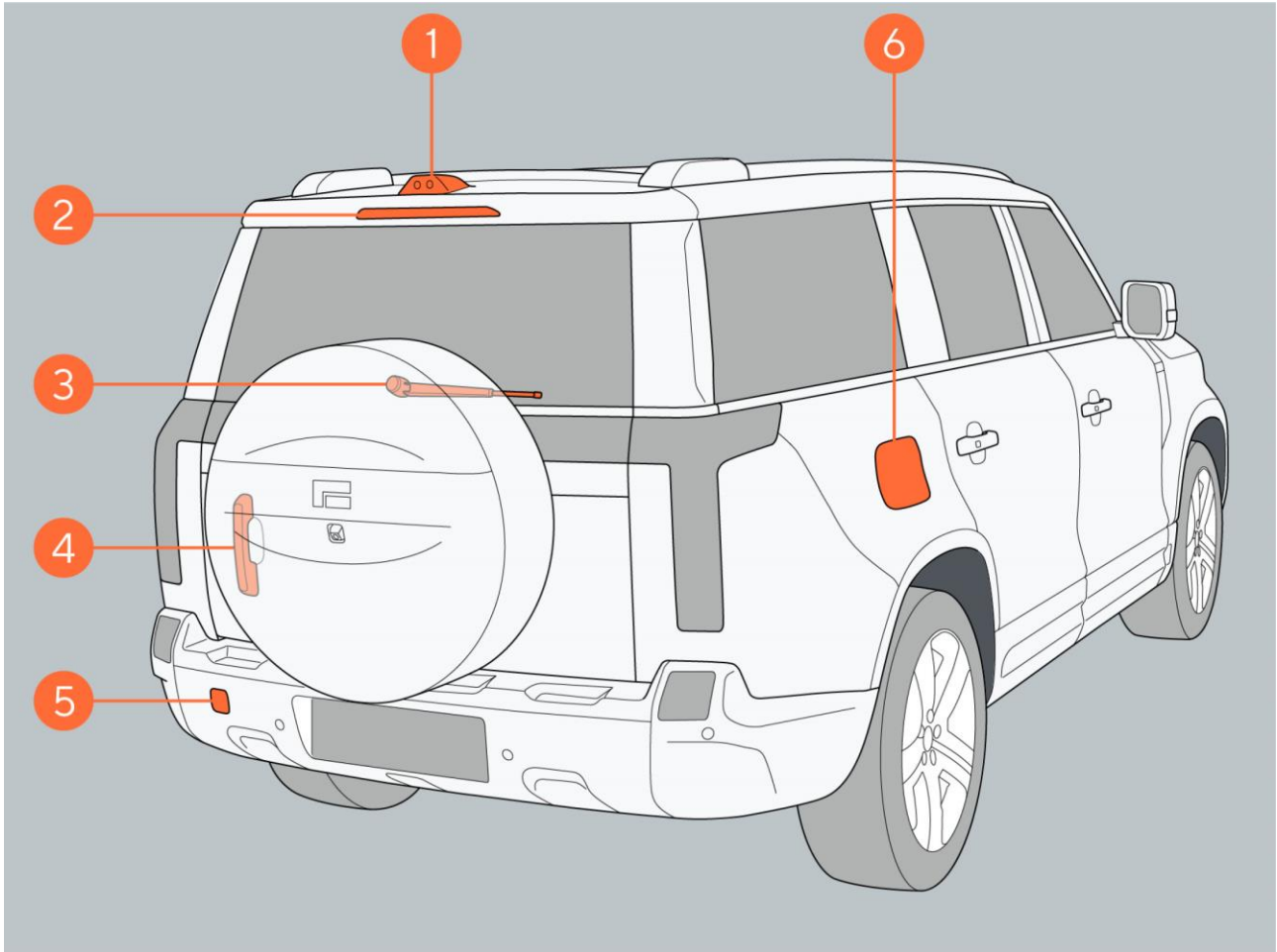

### 3. Picture index

#### 3.2 Interior

##### 3.2.1 Interior

S/N	Name	S/N	Name
1	Horn	2	Door inside handle
3	Front seat	4	Power window switch
5	Second row seat	6	Cup holder
7	Third row seat		

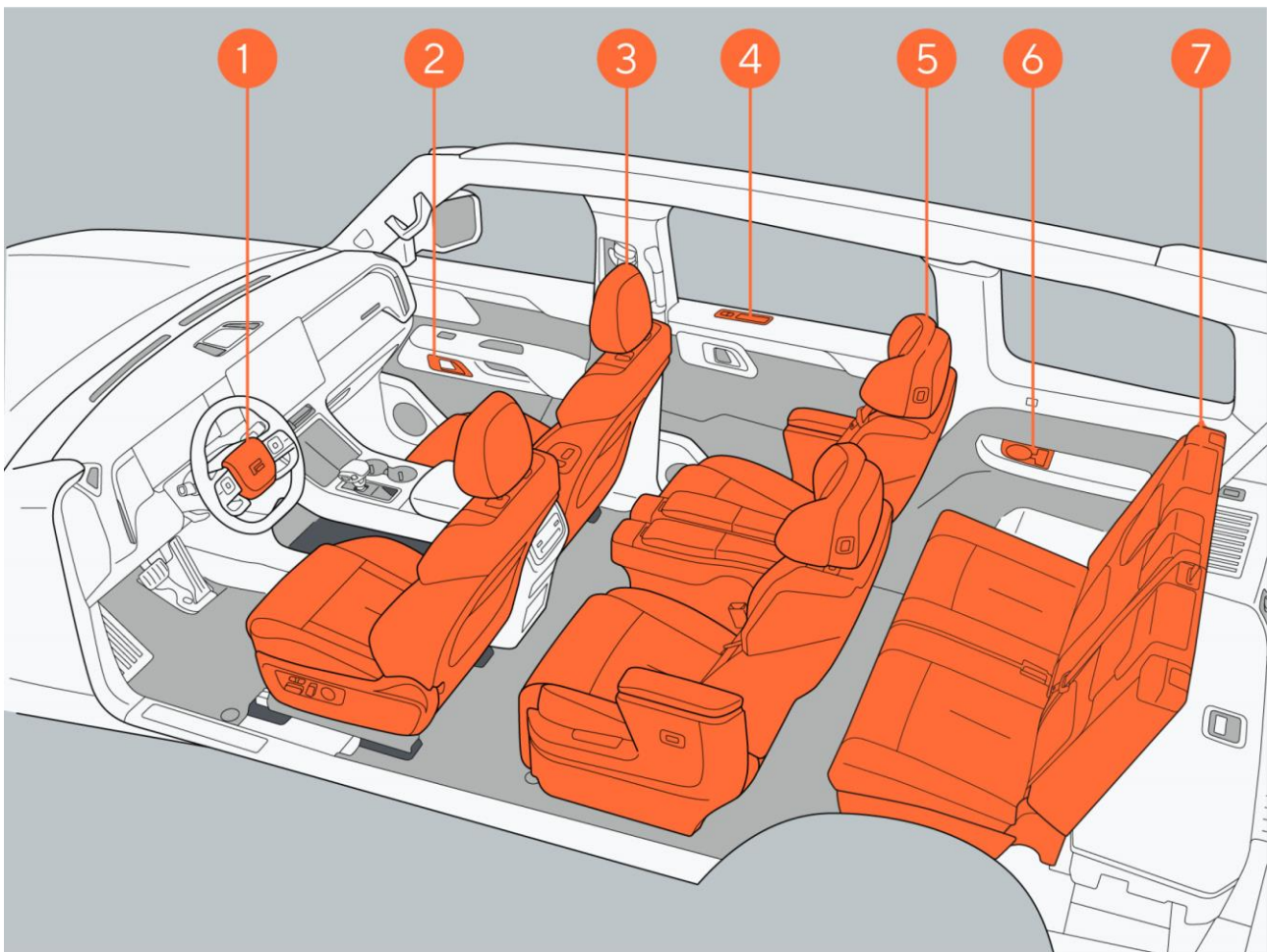

### 3. Picture index

S/N	Name	S/N	Name
1	Brake pedal	2	Accelerator pedal
3	Shift handle	4	Glove box
5	Rear row A/C control panel	6	Seat belt

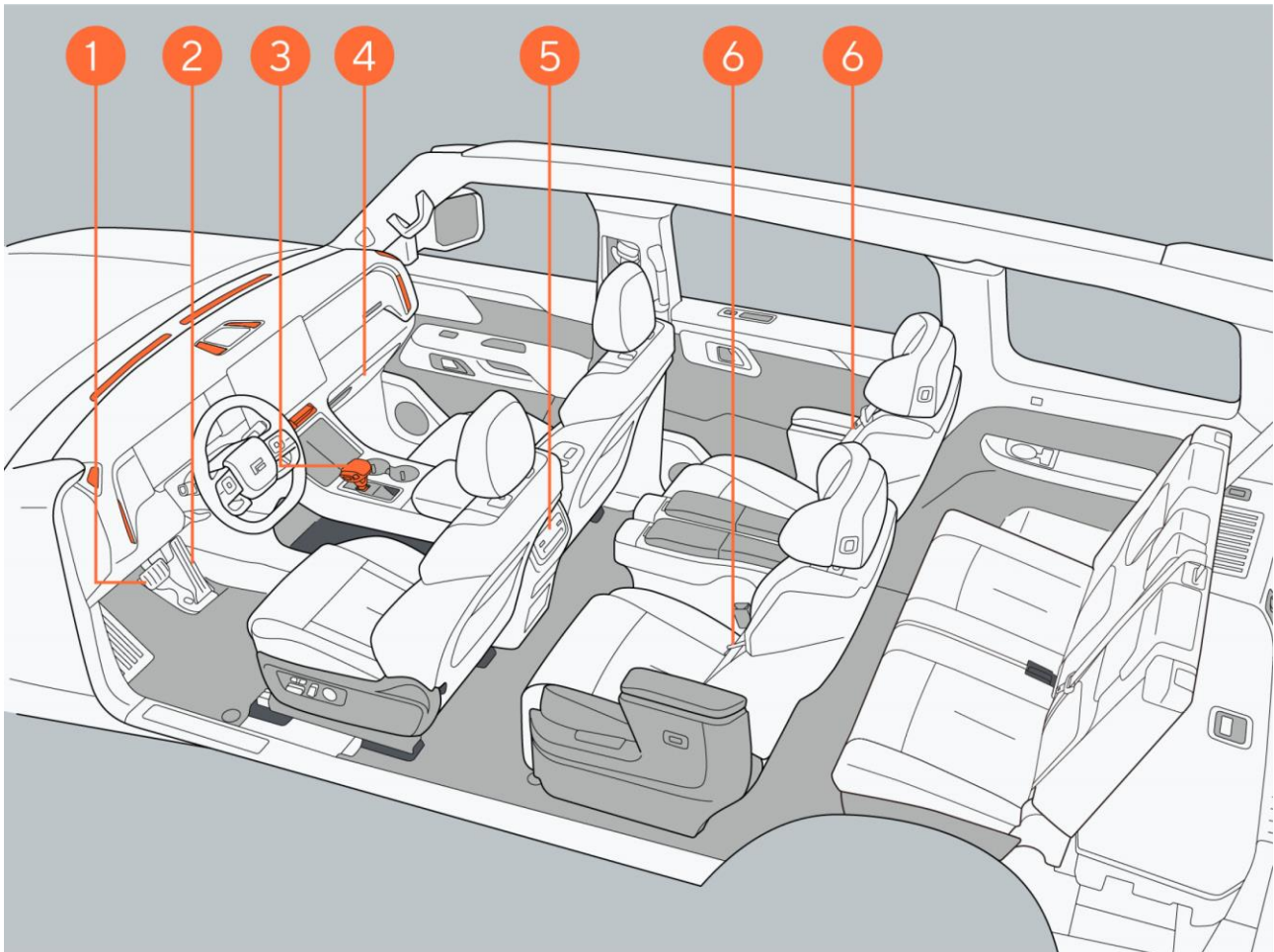



### 3. Picture index

S/N	Name	S/N	Name
1	Left steering wheel key	2	Right steering wheel key
3	Central control screen	4	Interior rearview mirror
5	Shift handle	6	Glove box

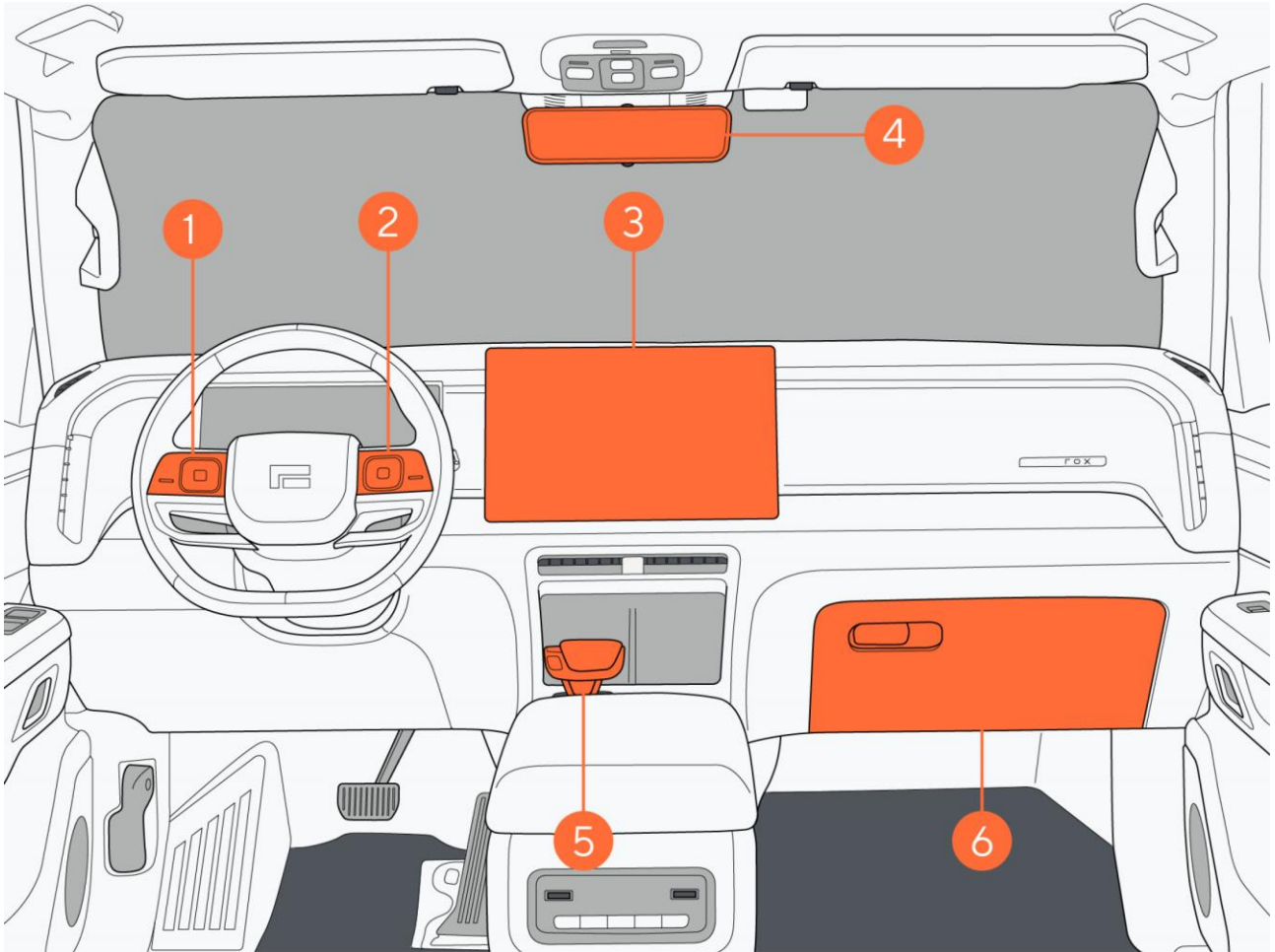

### 4.1 Instructions for safe use

#### 4.1.1 Before driving

For the safety and comfort of you and your passengers, the following checks are recommended before each drive:

- Make sure that all lights are functioning properly.
- Make sure that the fuel and electricity are sufficient.
- Make sure that there are no obstacles around the vehicle.
- Make sure that all windows are clear and have a good view.
- Make sure that there are no obstacles within the brake/accelerator pedal area, without affecting operation.
- Make sure that the tire pressure is normal.
- Correctly adjust the seats, headrests and interior/exterior rearview mirrors according to the driver's height and driving habits.

#### Warning

- Do not drive in high heels or slippers.
- Do not drive your vehicle after drinking alcohol.

#### 4.1.2 Safe driving

##### I. Adjust your sitting position

- Adjust the seat position to ensure that all pedals can be easily operated by your feet while driving. The distance between the steering wheel and your chest shall not be less than 250 mm.
- Adjust the seat backrest to ensure that the driver's back fits perfectly with the seat backrest.
- Adjust the seat headrest to make the ears flush with the center of the headrest, ensuring that the entire head is well supported.
- Pull out the seat belt and pass it from the front of the body, make the upper part of the seat belt close to the shoulder, and the lower part of the seat belt close to the hip, and then insert the seat belt lock tongue into the seat belt socket of the corresponding seat.

## 4. Safety instructions

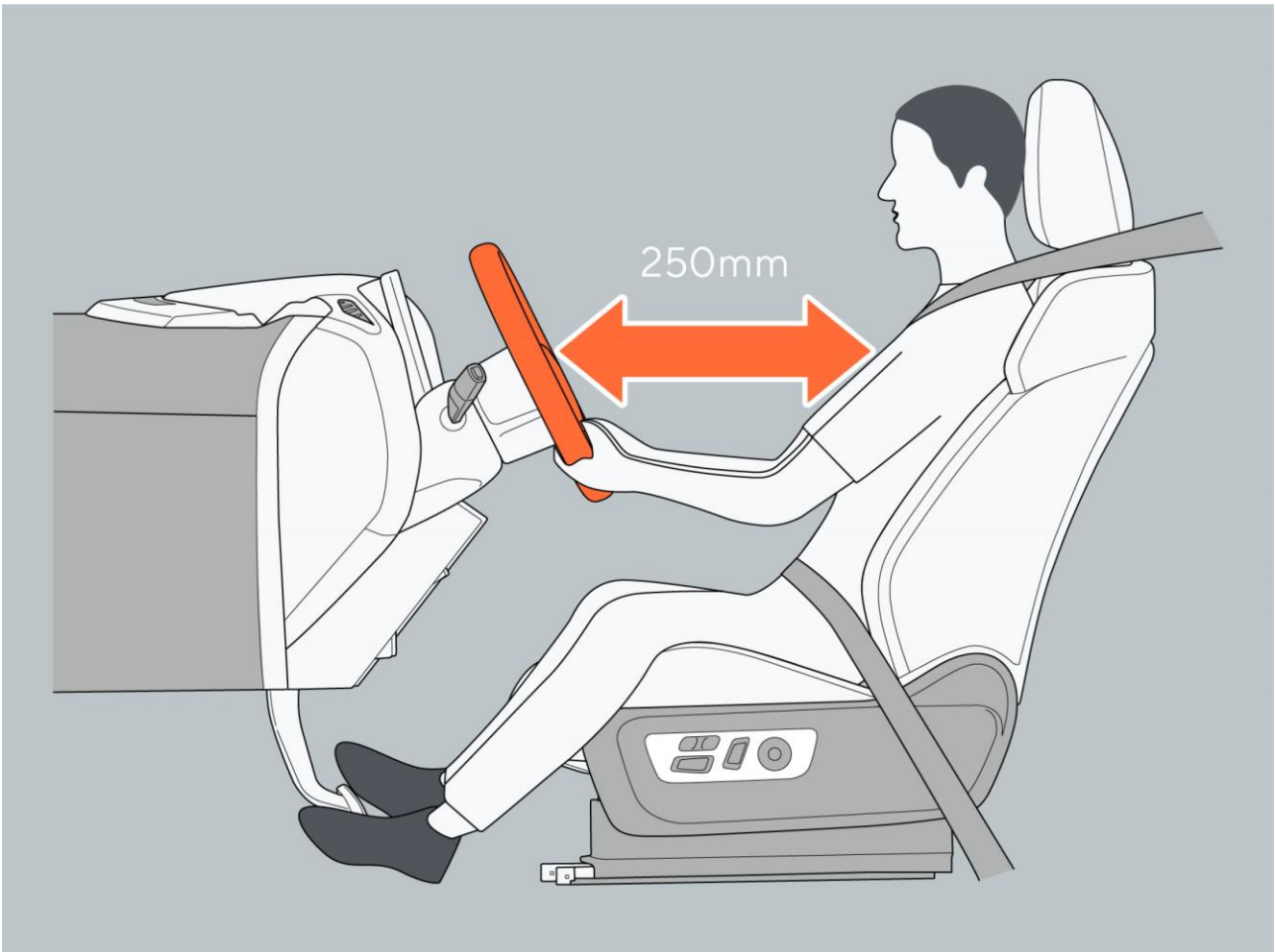

### II. How to use the seat belt

Before driving the vehicle, all driver and passengers of the vehicle should fasten their seat belts.

If there are children in the car, appropriate child safety seats should be used according to the age and size of the child.

### III. Adjustment of rearview mirror

Correctly adjusting the interior/exterior rearview mirrors before driving the vehicle can reduce blind spots and improve driving safety.

### IV. Prohibited items

- To ensure the safety of the vehicle and drivers and passengers, please do not store flammable and explosive items such as lighters, hairspray, perfume, alcohol, etc. in the vehicle. In summer or other high-temperature environments, flammable and explosive items in the car may cause a fire.
- Do not place items on the instrument panel. Items placed on the instrument panel will block the driver's view. Moreover, in case of a vehicle collision, the airbag will pop up, and the items placed on the instrument panel may pop up following the airbag, causing harm to the occupants in the car.
- Do not install ornaments on the windshield or window glass. Ornaments installed on the windshield will hinder the driver's vision. Moreover, when the vehicle is driving on bumpy roads, the ornaments may shake and break the glass.



## 4. Safety instructions

- Do not place items in the driver's foot space. During driving, items may move forward to the pedal area due to inertia, affecting the pedal movement and causing safety accidents.

### Warning

- Do not adjust the driver's seat while driving to avoid suddenly tilting your body that could cause the vehicle out of control.
- Do not adjust the exterior mirrors during driving to avoid blind spots, causing accidents or resulting in serious personal injury in accidents.
- Do not place anything under the driver's seat that may affect operation.
- Do not drive while fatigued or under the influence of alcohol.
- Please drive your vehicle strictly in accordance with the traffic rules.

### 4.1.3 Seat belt

#### I. Use seat belt correctly

1. Maintain a correct sitting position.
2. Pull the seat belt, and place the shoulder seat belt between your neck and shoulders.
3. Keep the waist seat belt as low as possible across your hips.
4. Do not twist seat belts.

## 4. Safety instructions

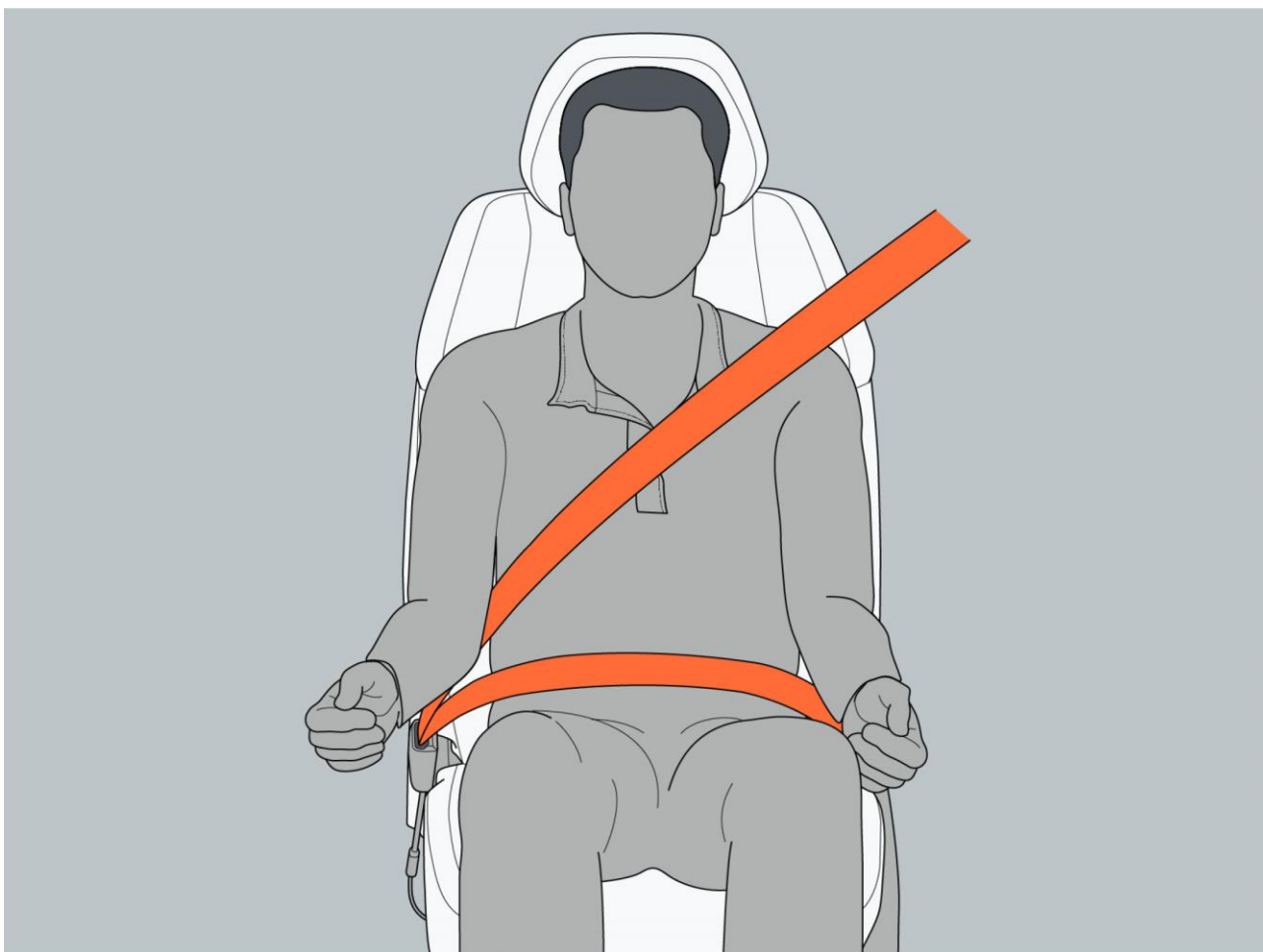

### II. Use a seat belt

When using the seat belt, slowly pull the seat belt out to an appropriate position, insert the seat belt tongue 1 into the buckle 2, until you hear a “click” sound. Then pull the seat belt to ensure that it is locked. When releasing the seat belt, press the red unlock button 3 to unlock the seat belt, and slowly retract the seat belt after unlocking.

### Warning

- Do not use one seat belt by multiple people to avoid failure to protect you in the event of an accident.
- Failure to wear seat belts or incorrect use of seat belts may result in casualties in the event of an accident.
- Do not drive the vehicle when the seat belt is severely worn and distorted. Be sure to replace the seat belt in time to avoid failure to protect you in the event of an accident.

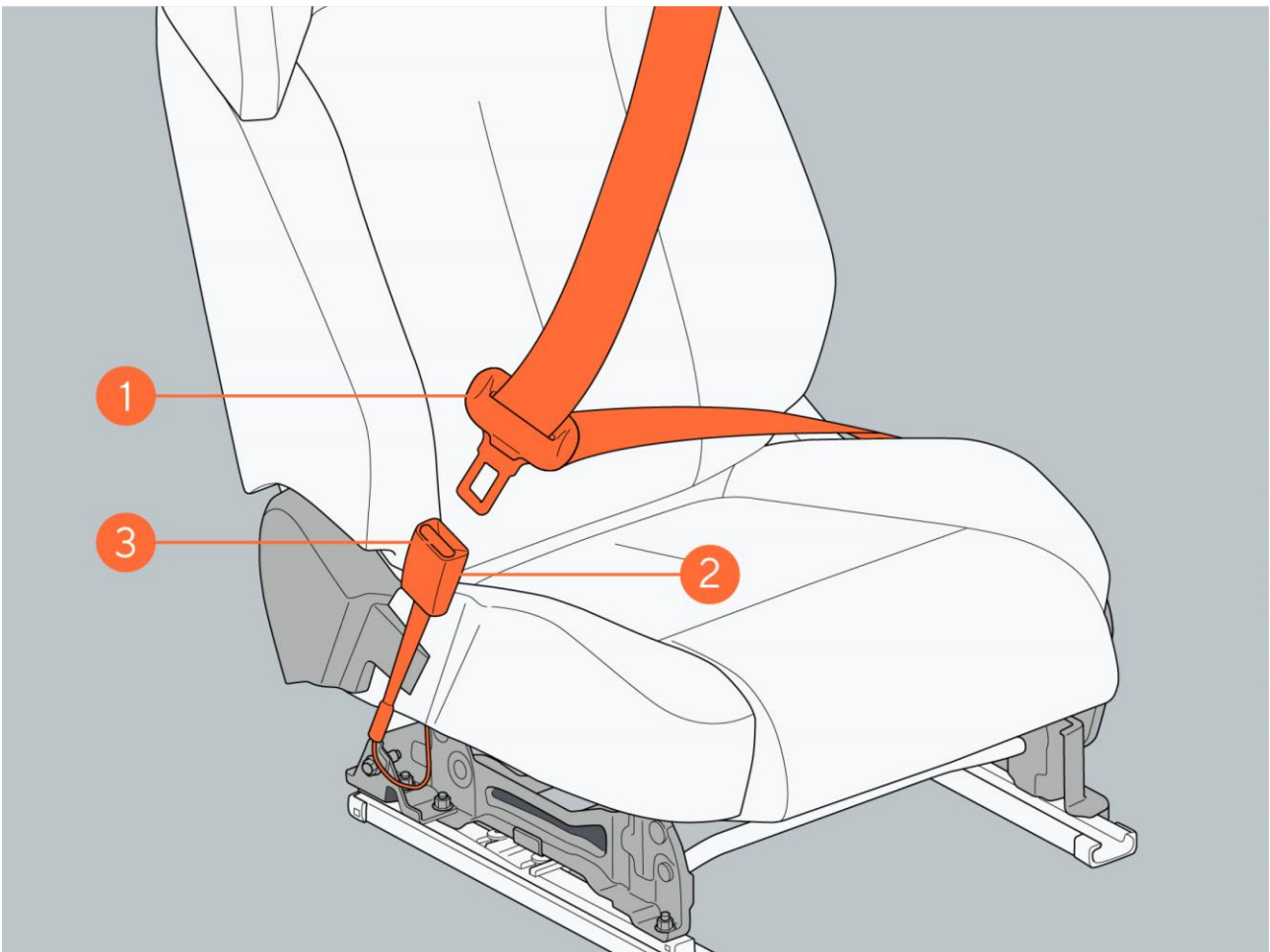

### III. Use seat belt correctly during pregnancy

I. The seat belt should be always be worn and used correctly during pregnancy.

Stretch the seat belt diagonally first, then put the shoulder seat belt through the middle of the shoulder and the center of the chest. Put the waist seat belt across the hip below the abdomen and lock it correctly. During using the seat belt, avoid touching the abdomen.

## 4. Safety instructions

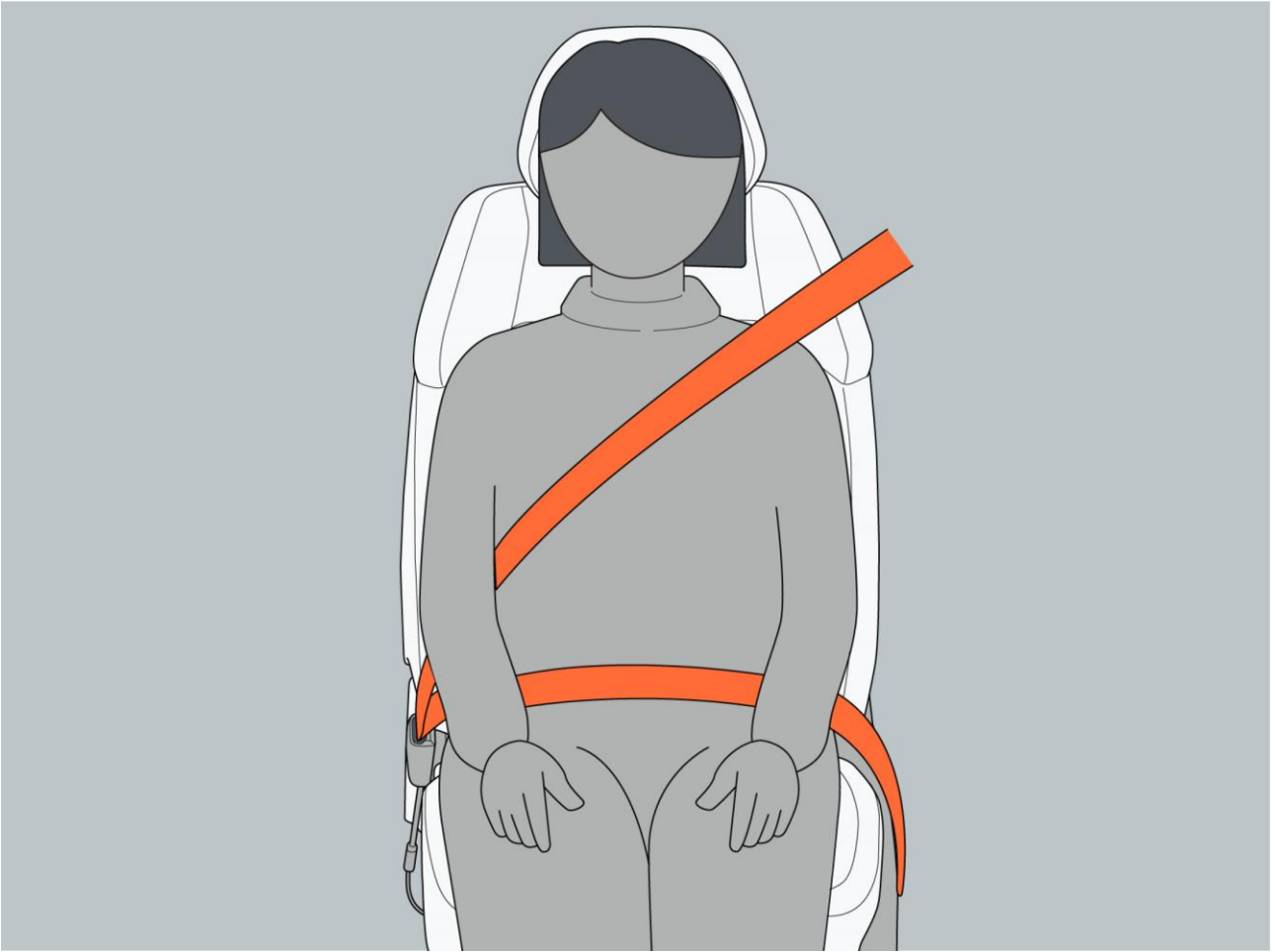

### IV. Seat belt height adjustment

Press the seat belt height unlock button, and adjust the shoulder belt height by sliding the height adjuster up or down.

#### **i** Tip

- Only front row belt height can be adjustable.

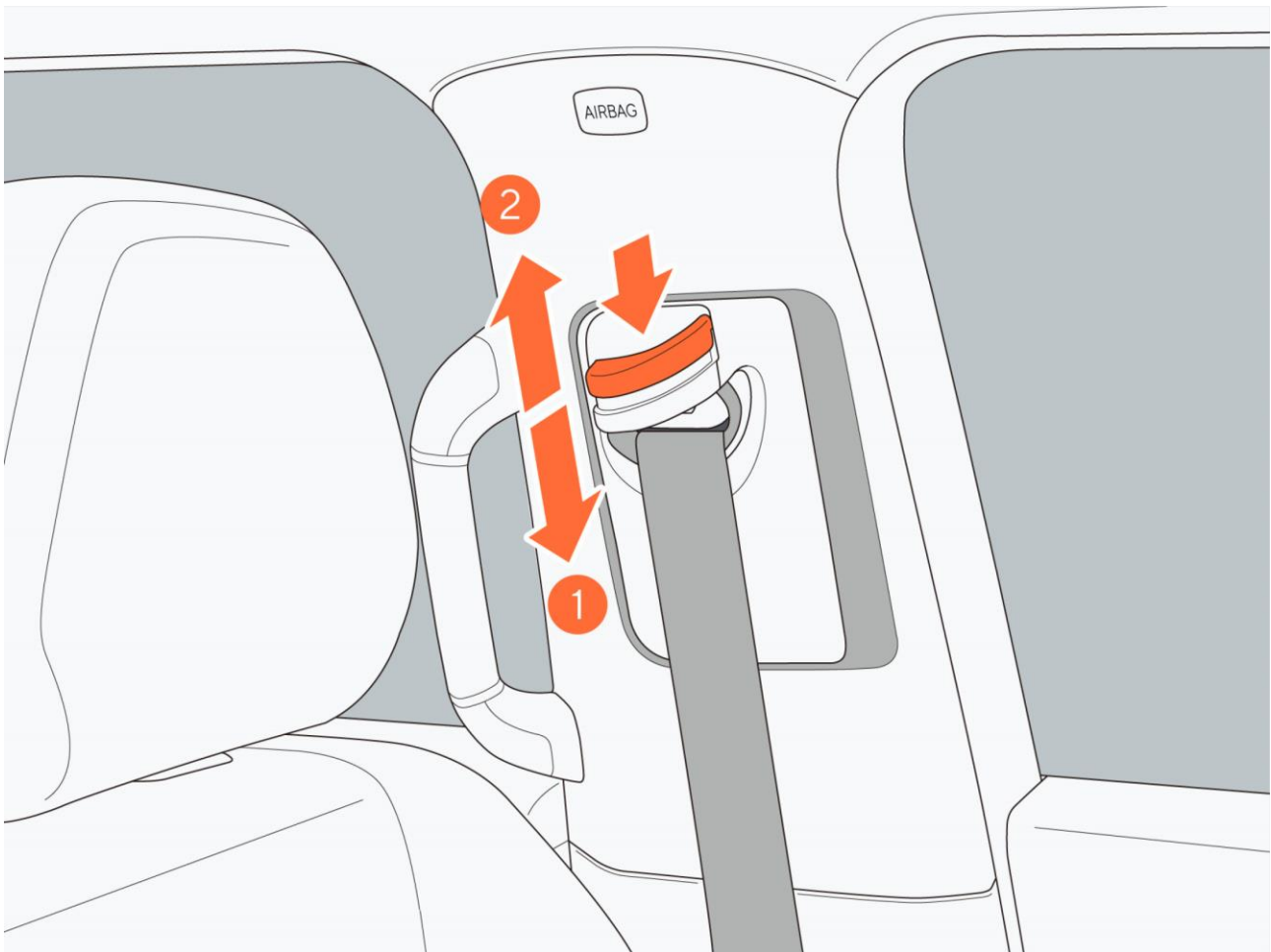

### V. Reminder for not wearing seat belts

The front and second rows of seats are equipped with occupant detection devices. If a driver or passenger is not wearing seat belts after the vehicle is started, the instrument screen will light up a warning light for not wearing seat belts.

When the vehicle has been driving for 1 min or over 500m, if the driver or the front occupant is not wearing a seat belt, the instrument screen will sound an alarm and the warning light that the seat belt is not wearing will flash. After 60s, if it is detected that the occupant in the front row is still not wearing seat belt, the alarm will continue to sound and the warning light that the seat belt is not wearing will flash. If only the occupant in the second row is not wearing seat belt, the alarm will stop after 60s. For your and occupants' safety, keep the seat belt fastened during your ride.

#### **i** Tip

- If there is still an alarm reminder after the seat belt is fastened, it indicates that the seat belt device is faulty or invalid. Please contact ROX Service Center for replacement or maintenance.
- Before driving, please do not place heavy objects on the seat to avoid false alarm of the system.

### VI. Seat belt tensioner

## 4. Safety instructions

Both the front and second row seat belts are equipped with tensioning devices. In the event of a serious collision, the tensioner will operate simultaneously the airbag. The tensioner automatically tightens the seat belt to reduce the forward lean of the driver and passengers.

### Warning

- Do not disassemble, install or modify seat belt components without authorization.
- Do not continue to use the seat belt tensioner after it is activated. Replace with a new seat belt and tensioner.
- Do not drive the vehicle when the seat belt cannot be locked, so as to prevent the seat belt from being unable to provide protection in the event of an accident.
- Do not drive the vehicle when the seat is not obviously damaged after a serious accident. Please contact ROX Service Center immediately and replace it if necessary.
- Do not tilt the seat back too far back, so as to prevent the seat belt from being unable to provide optimal protection in an accident.
- If pregnant women use seat belts, please use seat belts correctly. If the seat belts are used incorrectly, the seat belts will tighten the raised abdomen during emergency braking or collision, which may result in serious injury or even death to pregnant women and fetuses.
- For passengers with diseases, disabilities, etc., we recommend that you use seat belts. You can also get effective advice by consulting with a doctor.

### 4.1.4 Airbag

ROX 01 is equipped with 6 airbags to protect the driver and passengers.

The airbag can be quickly deployed in the event of a serious accident to protect the occupant's head and chest and reduce the degree of serious injury. However, the airbag cannot avoid injuries to the occupant's limbs and body surface. Therefore, the airbag must be used together with the seat belt to play the most protective role. There is the word "AIRBAG" at the airbag location to remind you that there is an airbag.

1. Side air curtain: Helps protect the head of the occupant in the outer seat.
2. Front airbags: Helps protect the head and chest of the driver and front occupant from hitting by the part in the car in the event of a collision.
3. Side airbags: Helps protect the torso area of the occupant in the front seat.

## 4. Safety instructions

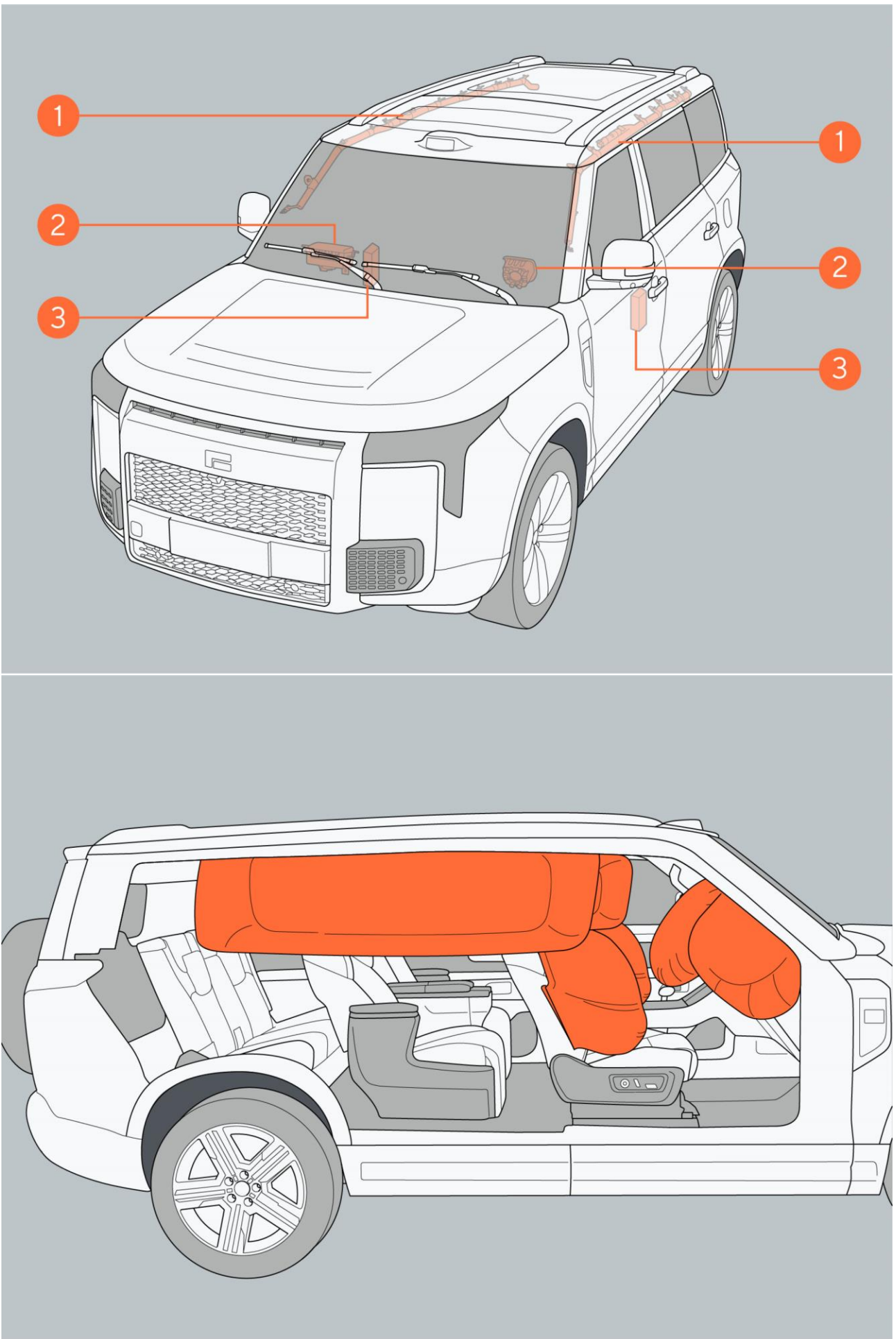

## 4. Safety instructions

### I. Deployment conditions of front airbags

When the collision of the vehicle reaches a certain degree of severity or exceeds the set critical value, the front airbag will be deployed.

### II. Airbag deployment

When the airbag is deployed, the following will occur:

- When the airbag is deployed, it may cause the driver and passengers to be bruised or scalded.
- When the airbag is detonated, it can generate smoke and dust.
- After the airbag is deployed, the airbag and seat parts will become hot.
- Windshields may be broken.

### III. Deployment conditions of side air curtain and side air bag

- When the collision reaches a certain degree of intensity or exceeds the set critical value, the side air curtain and side air bag will be deployed.
- Side airbags and side air curtains can also be deployed in the event of a serious head-on collision or rollover.



## 4. Safety instructions

### IV. Possible deployment of airbags except for collisions

If the bottom of the vehicle suffers a serious collision or the vehicle quickly drives through a deep pit, etc., the front airbag, side airbag and side air curtain may also be deployed, such as:

- Hitting the hard roadbed.
- Falling into a deep ditch.
- Hard landing of wheels or falling of the vehicle.

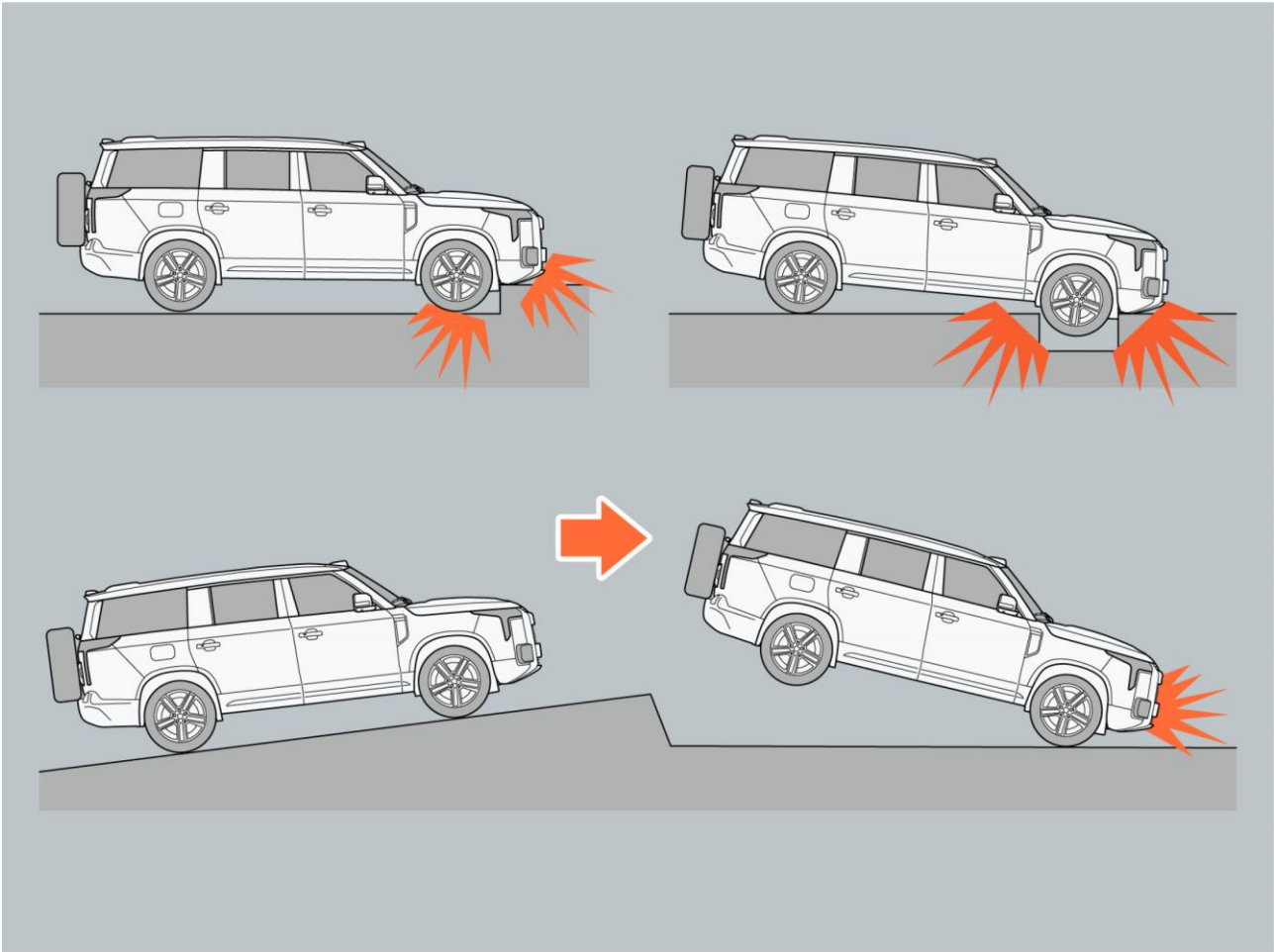

## 4. Safety instructions

### V. Impossible deployment of front airbags

When the vehicle suffers a low-speed head-on collision, side collision, rear collision, or rollover, the front airbag generally will not be deployed, such as:

#### 1. Side collision.

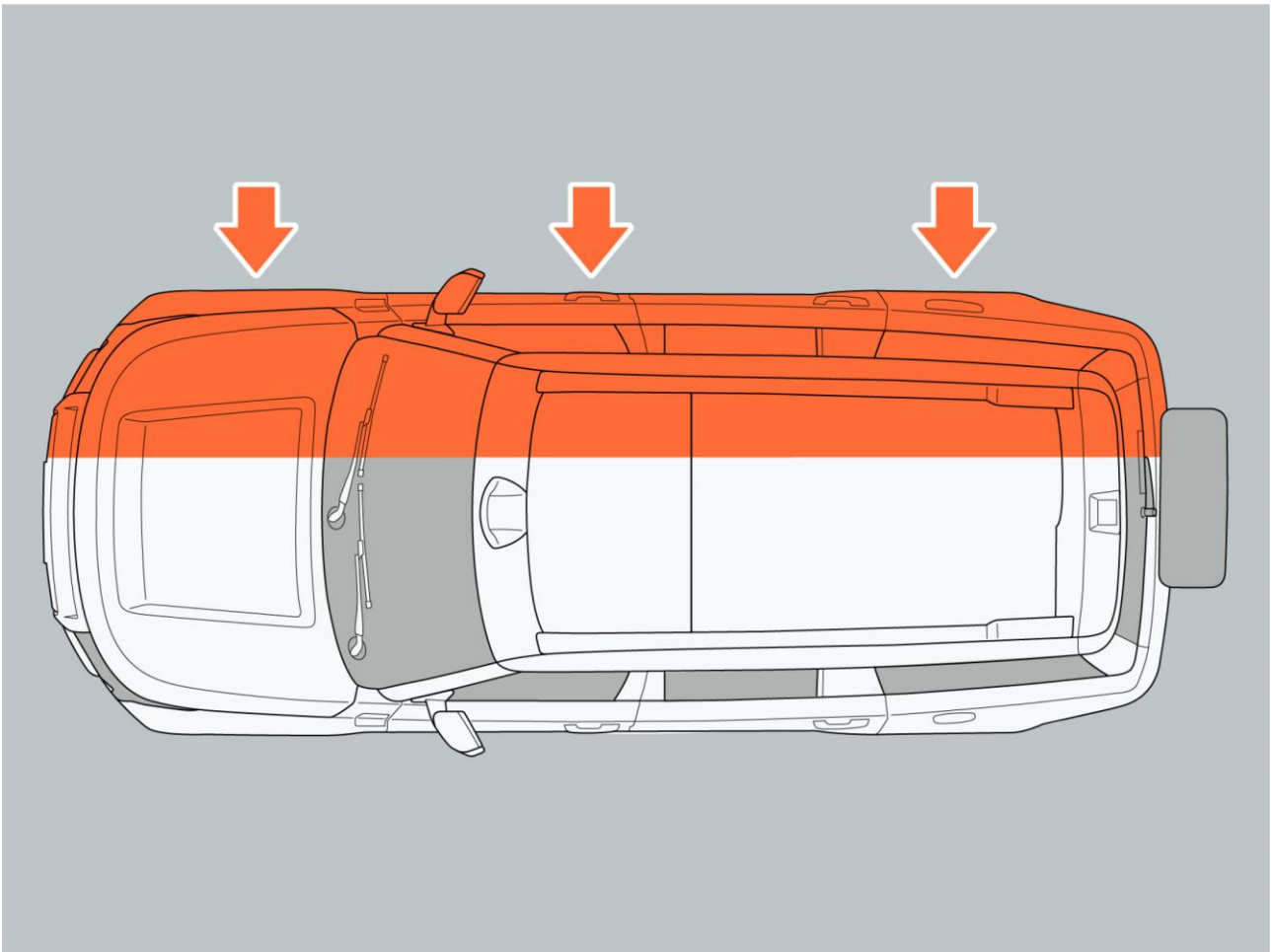

## 4. Safety instructions

### 2. Rear collision or rear-ended.

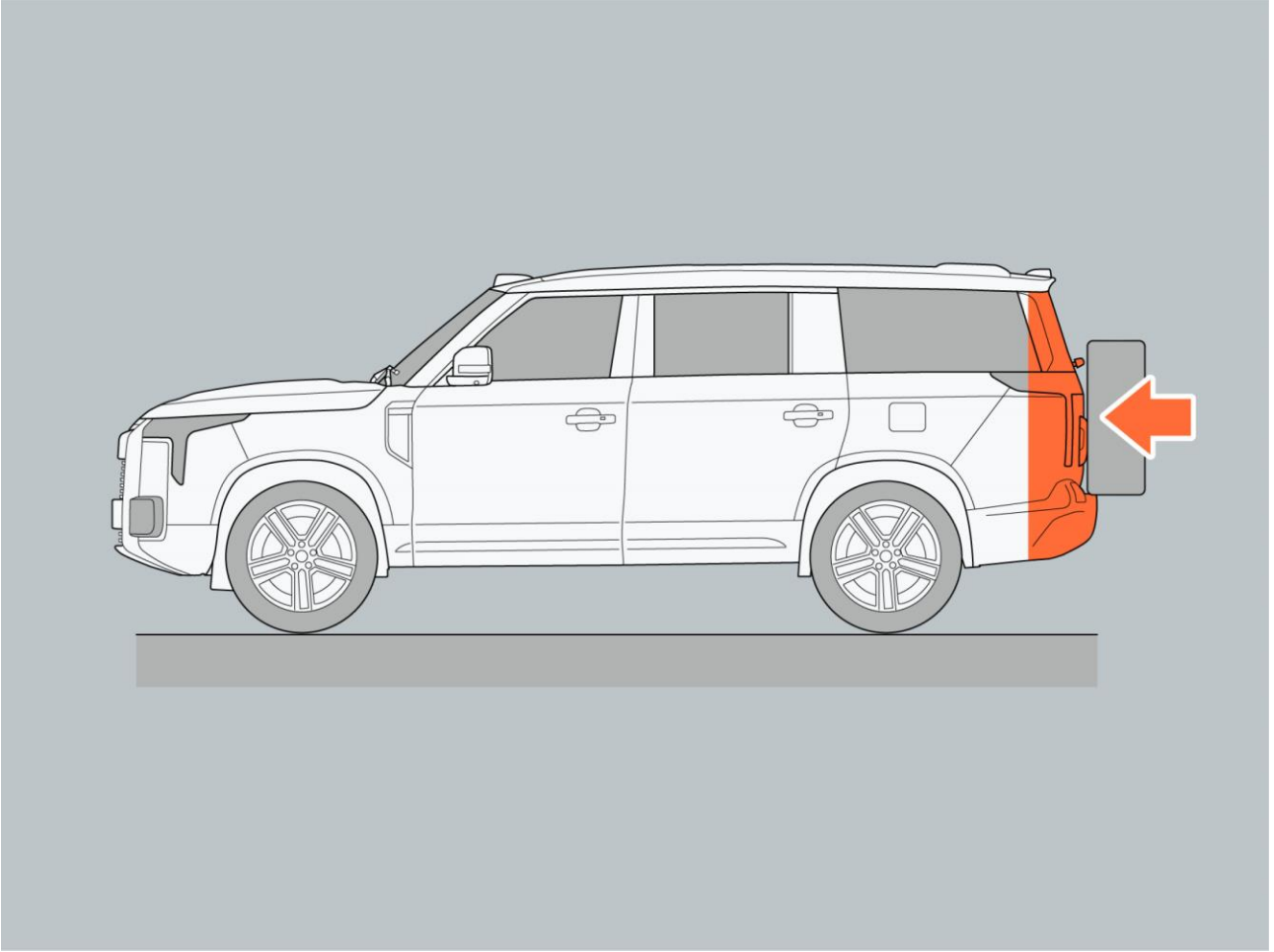

## 4. Safety instructions

### 3. Rollover.

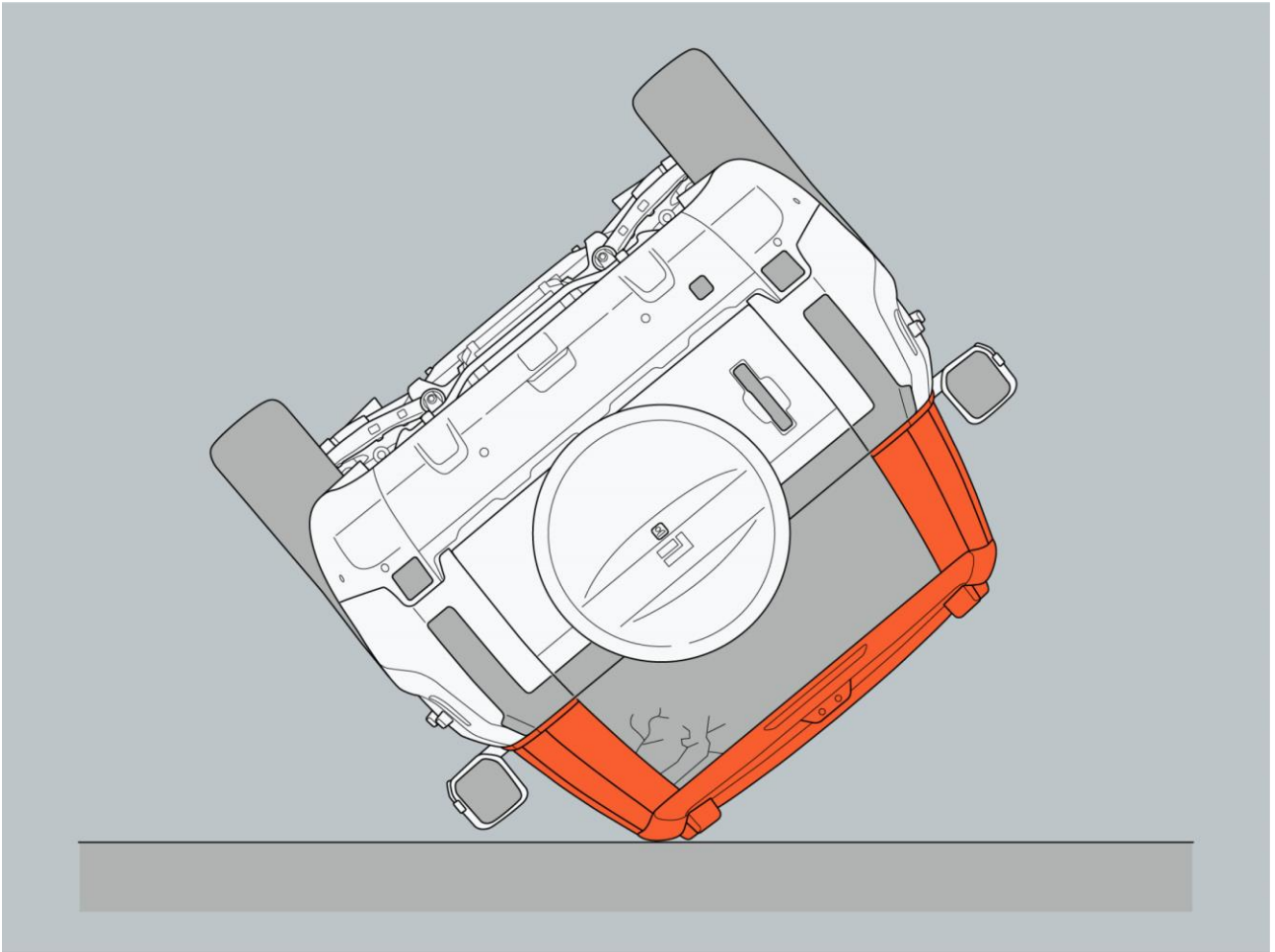

## 4. Safety instructions

4. When the vehicle hits an object with small area such as a utility pole or a small tree at a low speed, the airbag may not be deployed.

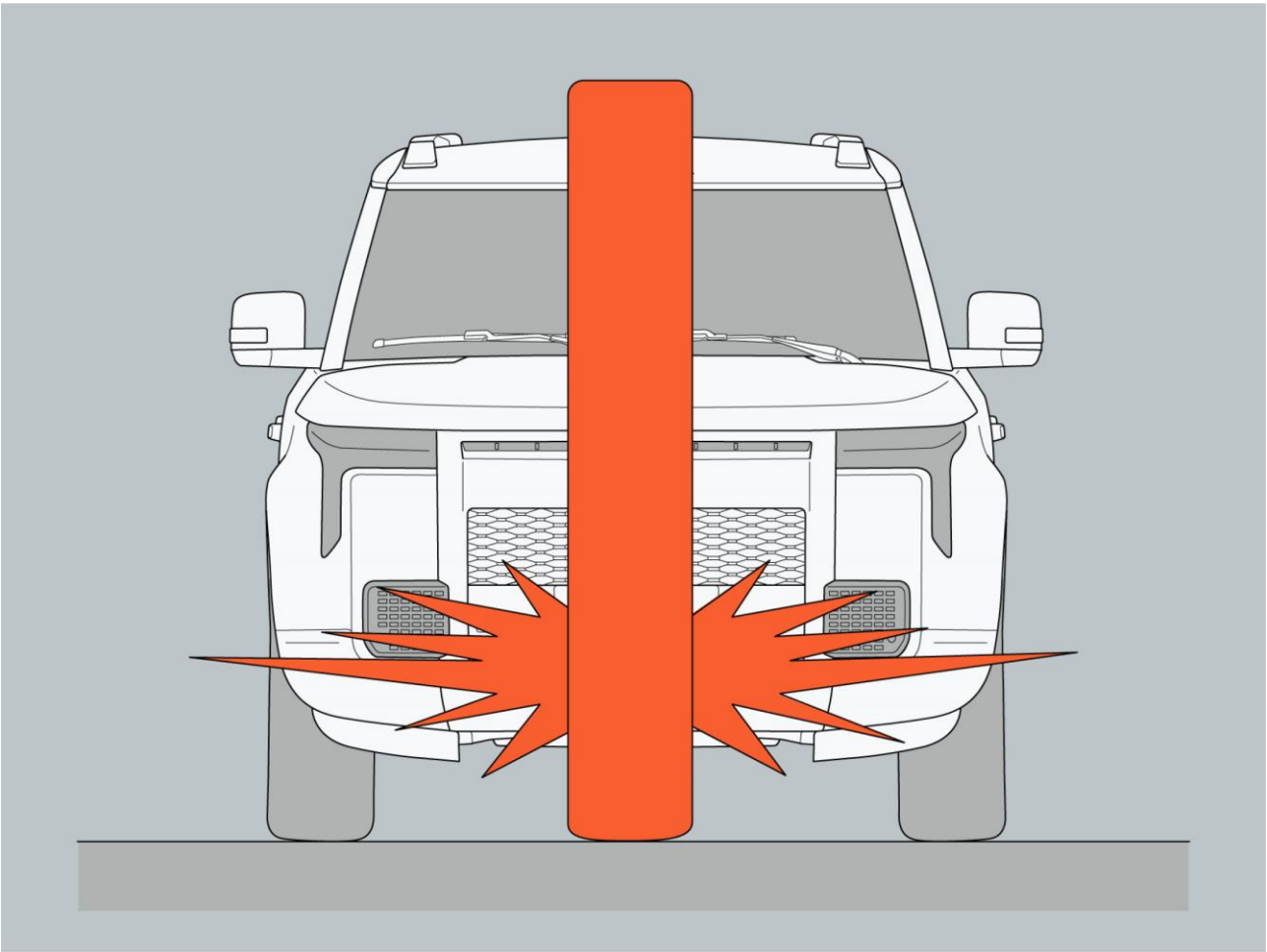

## 4. Safety instructions

5. When the vehicle rear-ended underneath the rear of a truck, the airbag may not be deployed.
6. If the collided object deforms or moves, the impact force caused by the collision will be reduced, and the airbag may not be deployed.

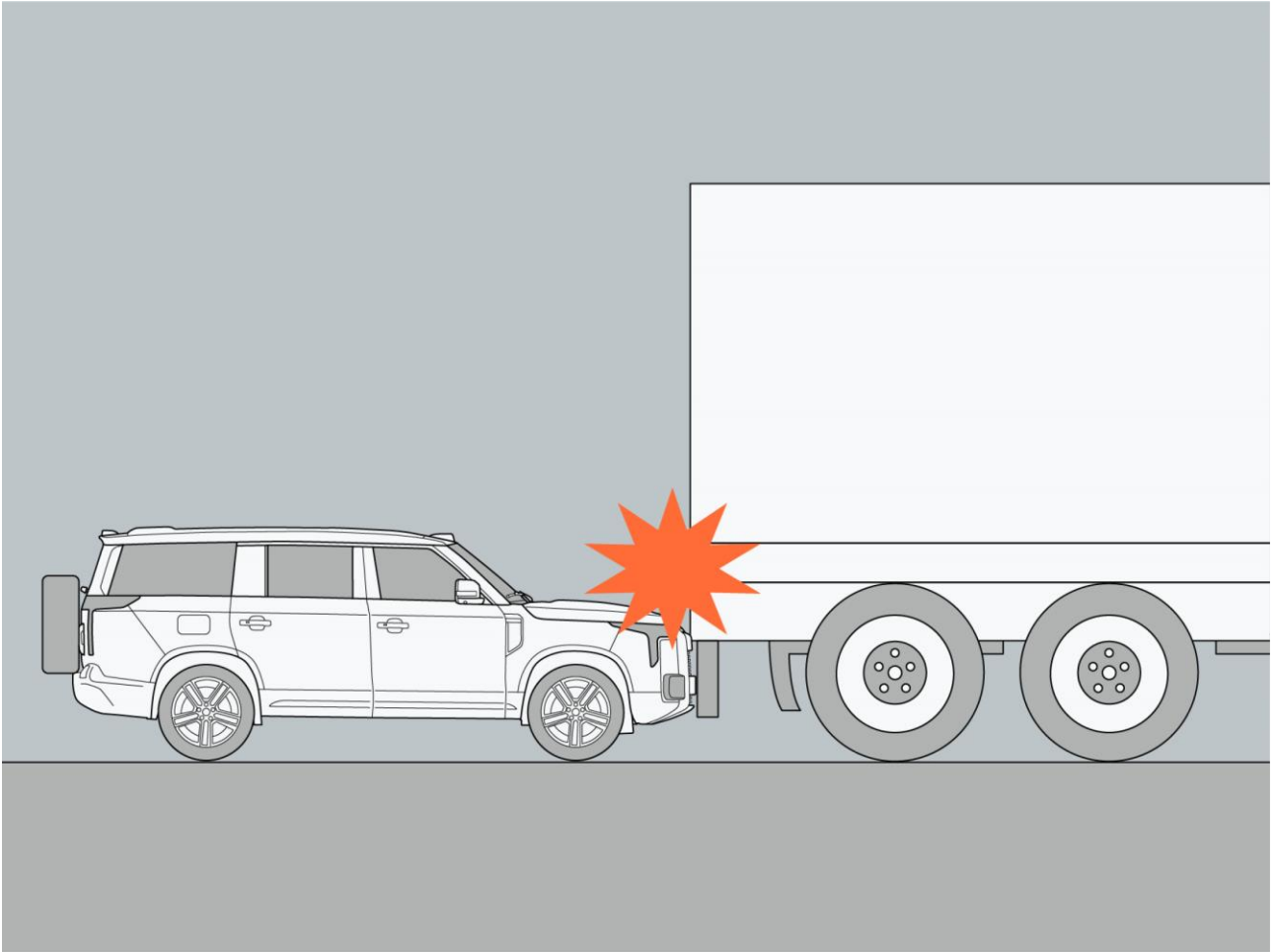

## 4. Safety instructions

VI. Impossible deployment of side air curtains and side airbags

1. When the vehicle suffers a low-speed side collision or rear collision.

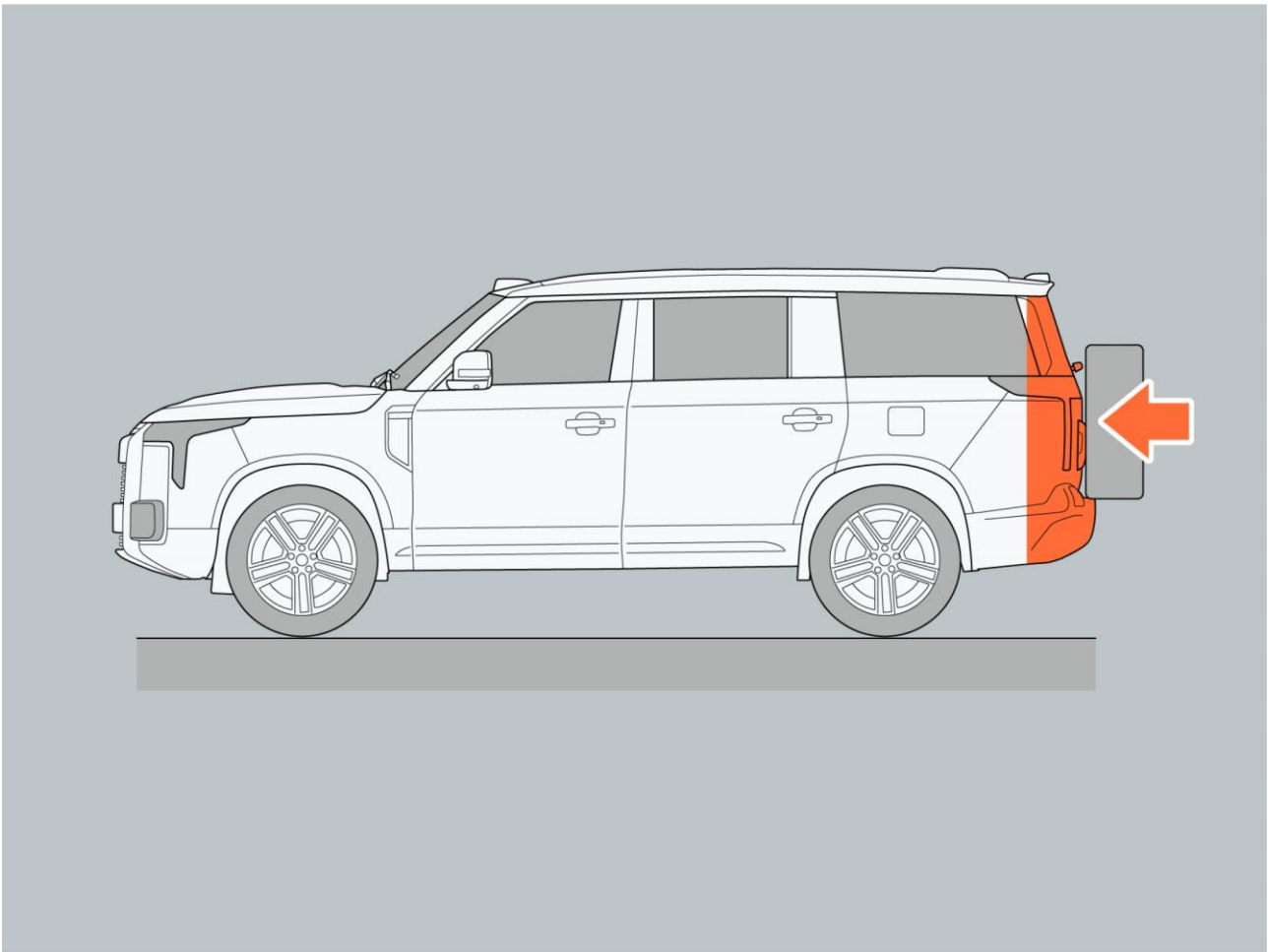

## 4. Safety instructions

2. The side is scratched.

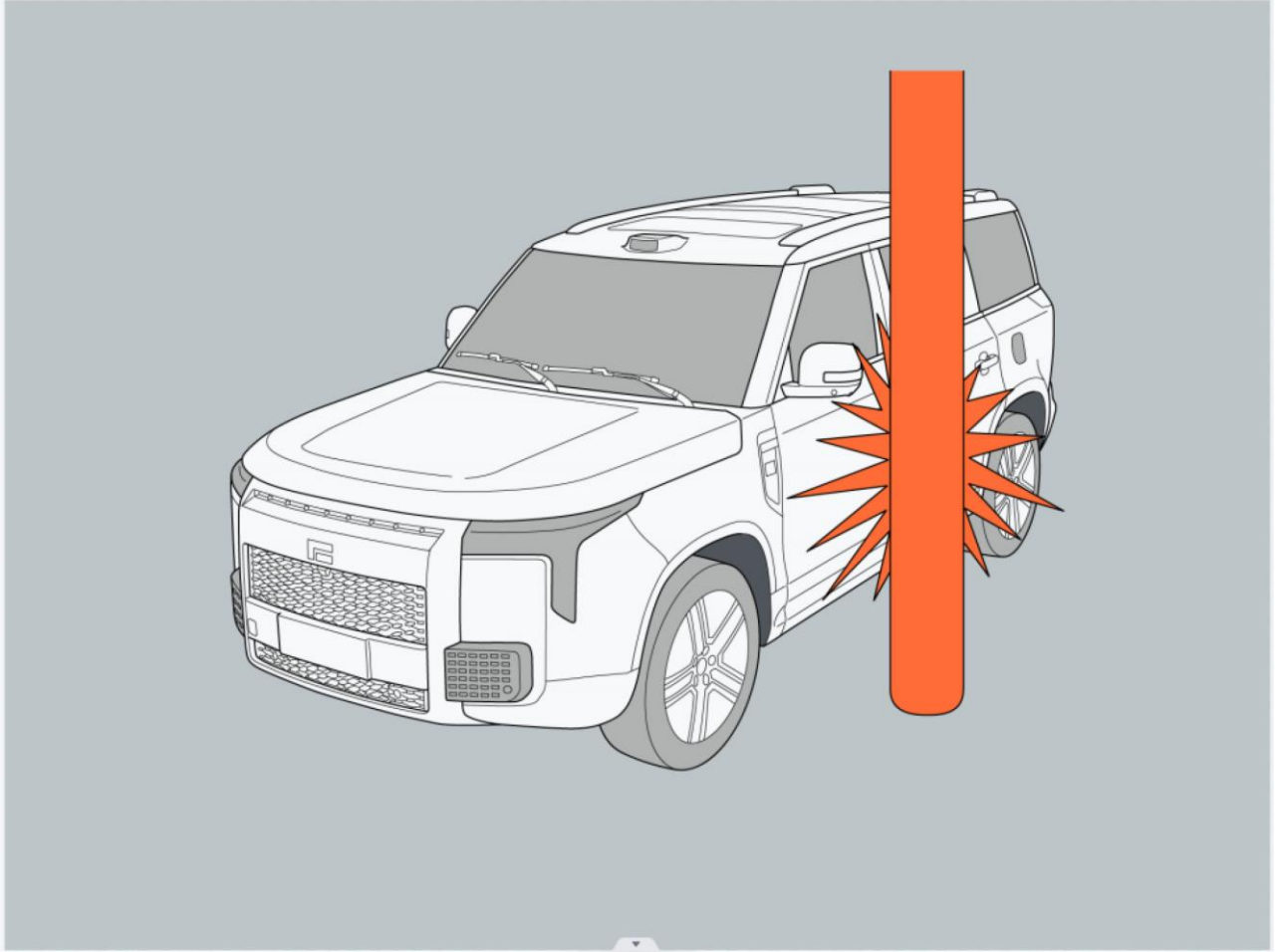



## 4. Safety instructions

3. The body of a non-passenger car suffers a side collision.

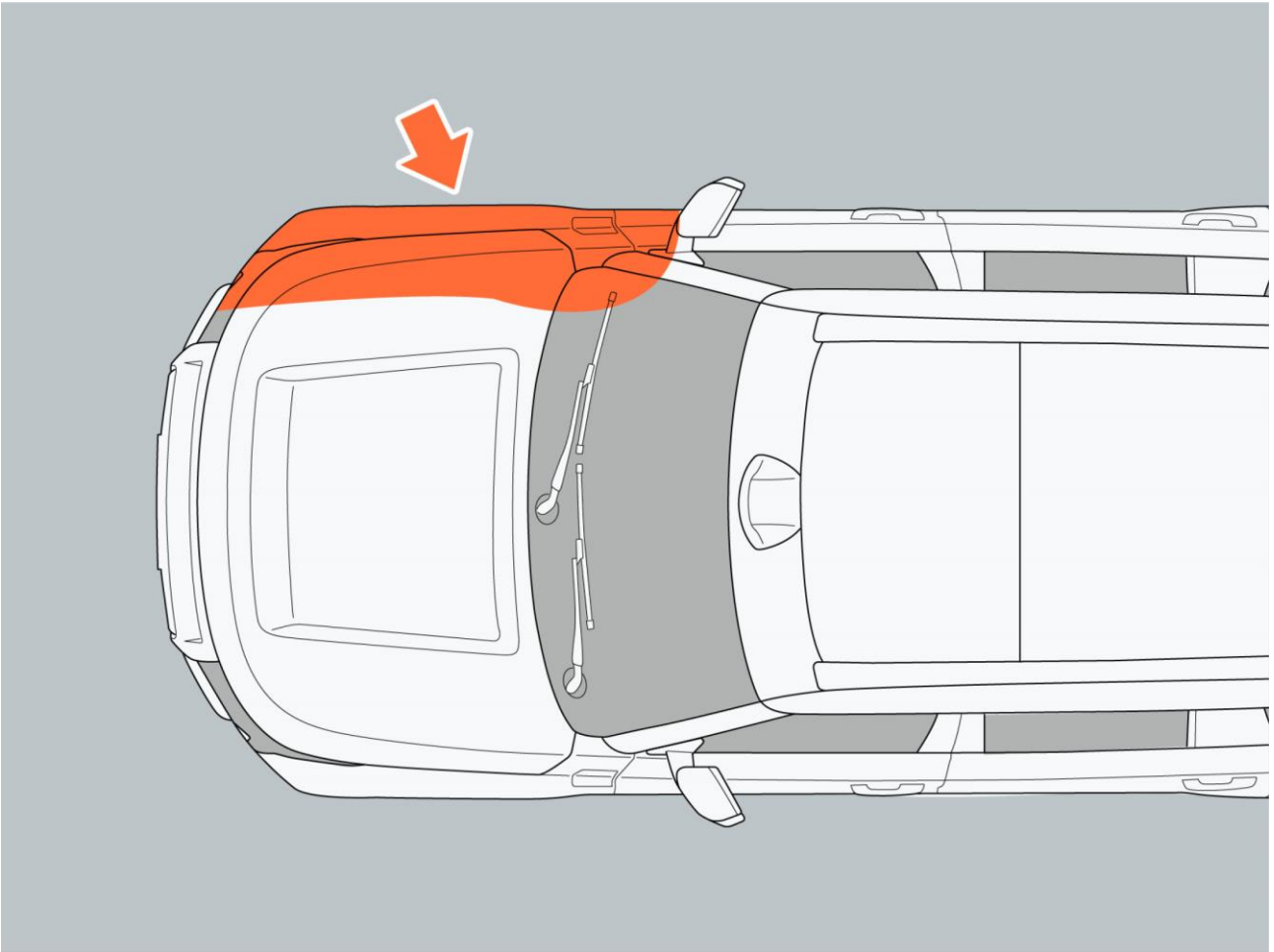

## 4. Safety instructions

### VII. Install seat covers on the seats

Do not install seat covers and other items on the vehicle seats. The seat covers may affect the normal deployment of the side airbags in case of a collide, thus failing to effectively protect the drivers and passengers.

#### Warning

- Do not touch the accessories of the airbag after its deployment to avoid burns.
- The protection function of the airbag system can only be triggered once. If the airbag has been triggered, be sure to replace it. It can prevent from failing to play a protective role in case of a collision.
- Do not drive the vehicle when the airbag (such as the steering wheel trim cover) is damaged or cracked, so as to avoid serious personal injury caused by the sudden deployment of the airbag or the failure to deploy in an accident.
- Do not hit the airbag assembly hard to avoid accidental deployment of the airbag.
- Do not install accessories and other items on the instrument panel to avoid secondary damage caused by the deployment of the airbag.
- Do not hang any hard objects (such as clothes hangers, glass bottles, etc.) at the coat hook to prevent secondary damage caused by the detonation of the side air curtain.
- Do not place your feet or other parts of your body on the airbag during driving, so as to prevent secondary injury caused by the deployment of the airbag in an accident.
- Do not disassemble or install airbag components without authorization.
- Do not hold an infant or a child on your knees. Otherwise, the infant or the child will be seriously injured or even killed in a collision. All infants and children should be properly protected by child safety seats or seat belts in the rear seats.

#### Caution

- If the airbag is not activated at the time of collision, it does not indicate that the airbag is faulty. The strength or type of collision is not enough to activate the airbag.









#### Tip

- As a supplemental safety system, the airbag cannot replace the seat belt in respect of protection. It must be used together with the seat belt to provide the best protection for the driver and passengers. Therefore, all driver and passengers in the car must fasten the seat belt and maintain the correct sitting position.

## 4. Safety instructions

### 4.1.5 High voltage system

#### I. Emergency rescue information

Icon	Name	Icon	Name
	High voltage part		Airbag controller
	Seat belt pretensioner		Stiffener
	Side air curtain cylinder		Fuel tank
	Air spring		Airbag
	Low voltage battery		

Configuration 1

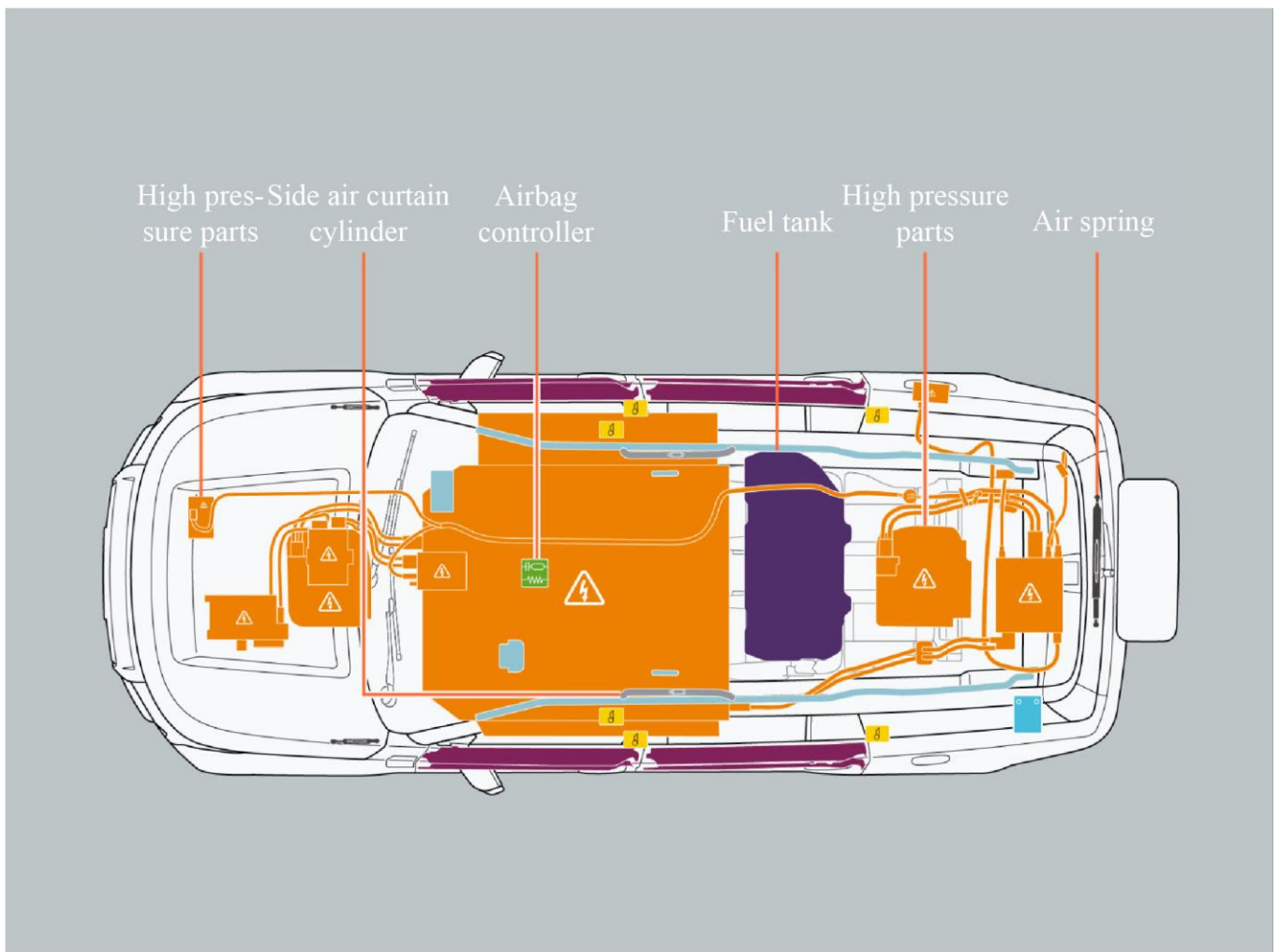

## 4. Safety instructions

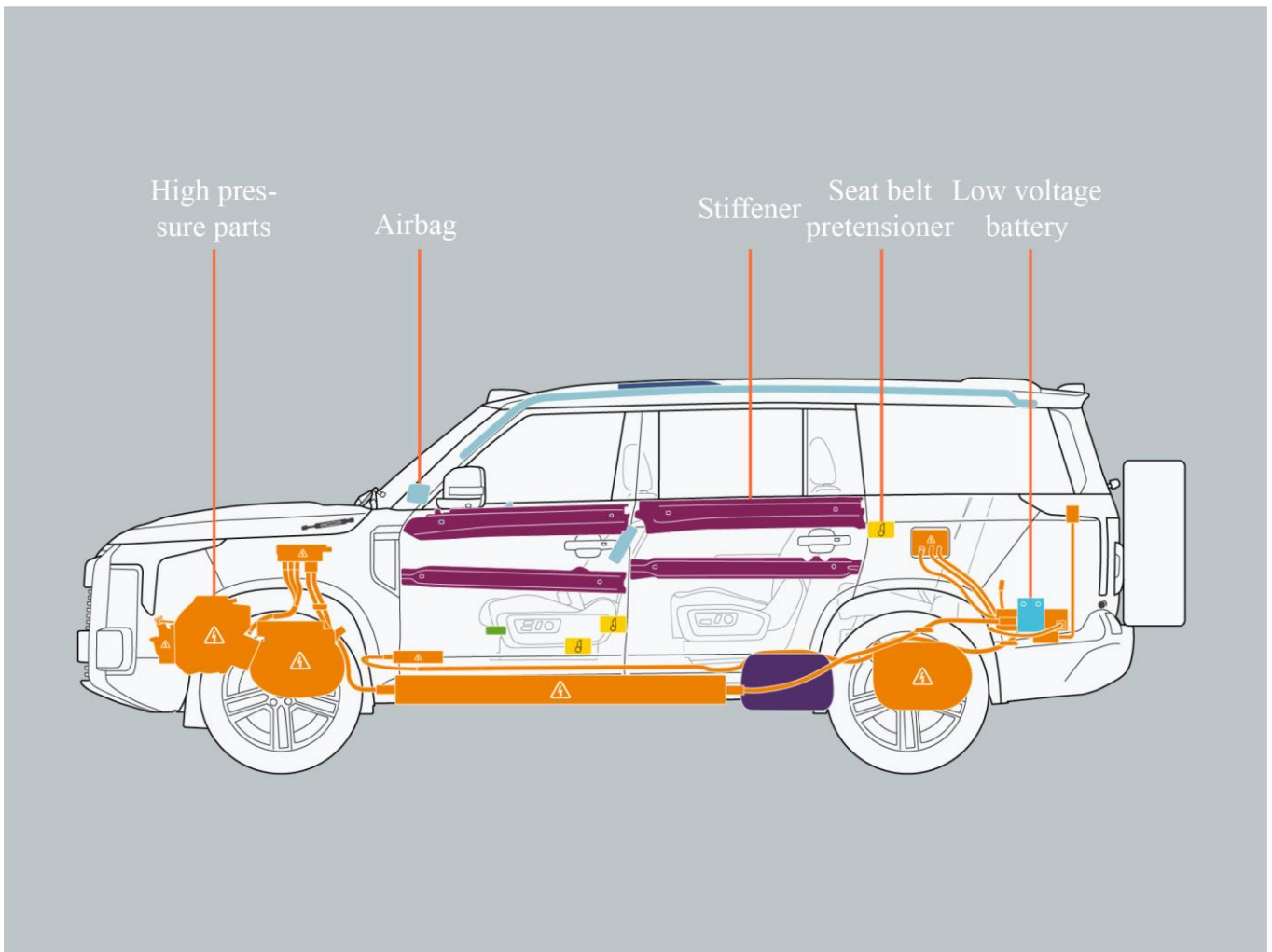

## 4. Safety instructions

Configuration 2

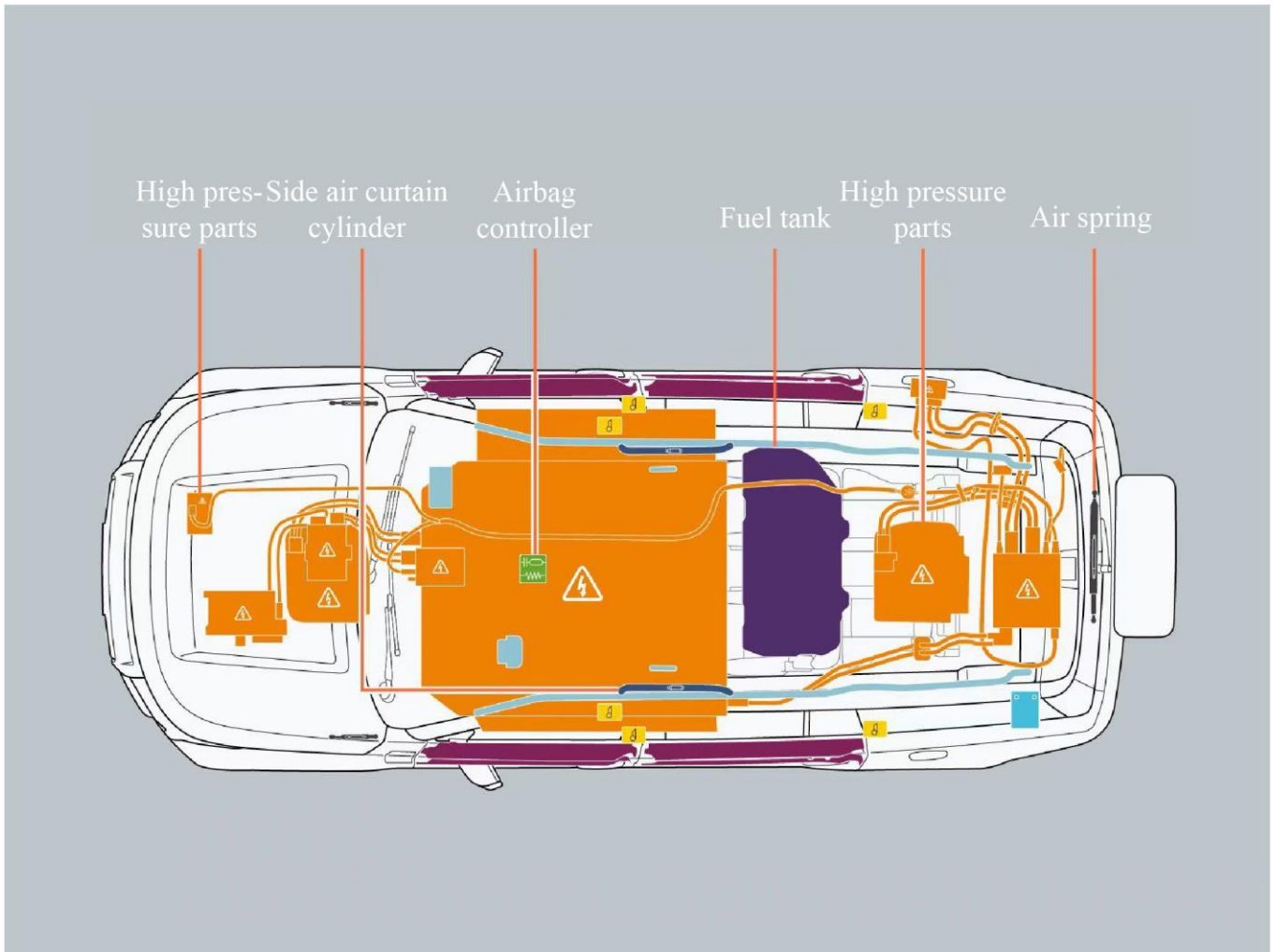

## 4. Safety instructions

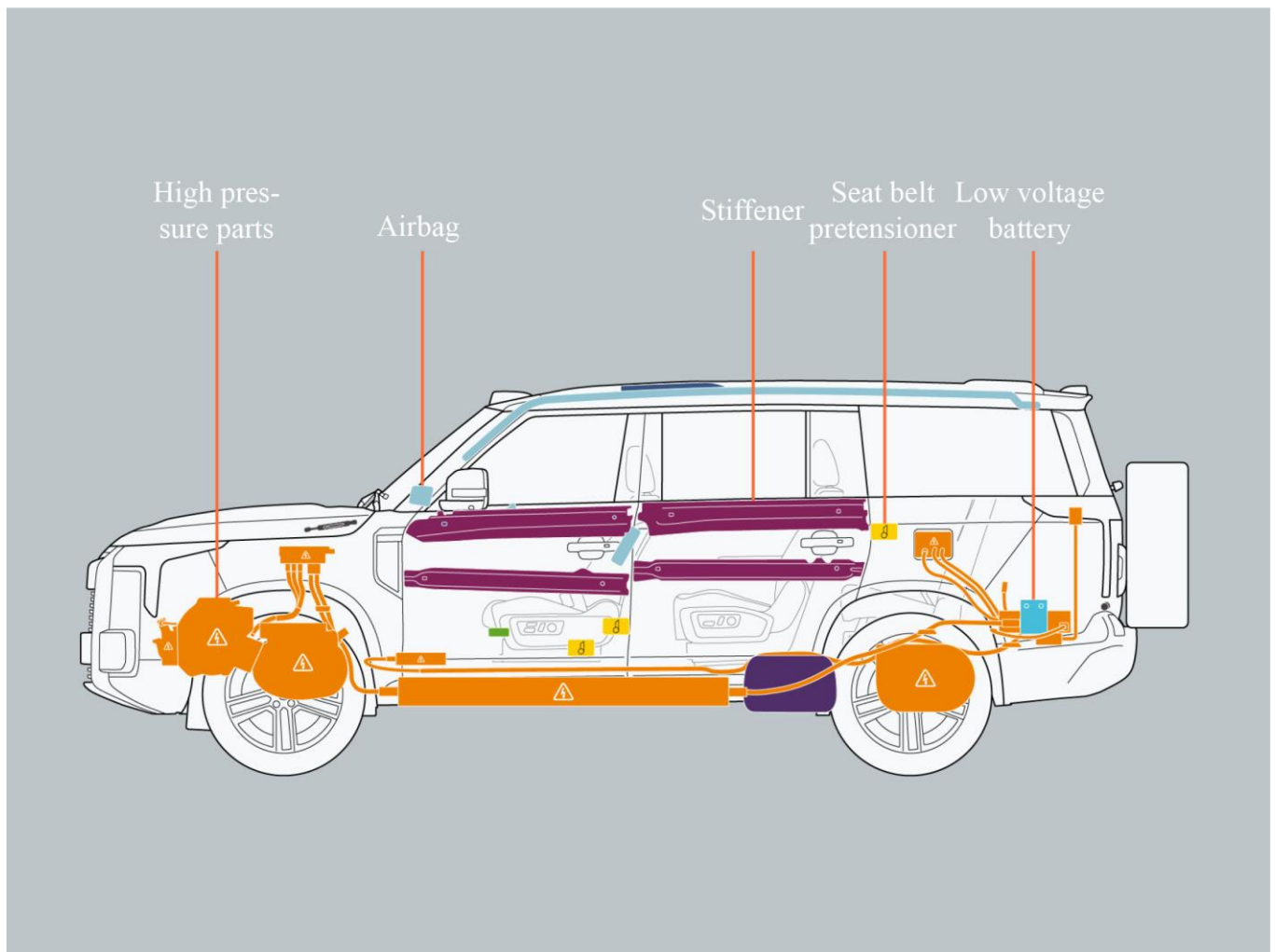

### II. Automatic shutdown of high-voltage system

In the event of a serious collision, the high-voltage system will be cut off urgently to avoid threatening the driver, passengers and other traffic participants.

#### 4.1.6 Precautions for waste gas

The exhaust gas emitted by the vehicle contains colorless and odorless harmful substances, such as carbon monoxide (CO), particulate matter, etc. Staying in an environment with high exhaust gas content for a long time will endanger health and even lead to death due to inhalation of too many harmful substances. If you are uncomfortable due to inhalation of too much exhaust gas, you should move to an open area as soon as possible. If it is serious, please seek medical attention in time.

### Warning

- Carbon monoxide gas is poisonous. Inhalation in large quantities will lead to loss of consciousness and even death.
- Do not operate the range extender system for long time in a poorly ventilated environment.
- When the car doors and trunk doors are closed and the car exhaust can still be smelled, it is necessary to open the windows in time for ventilation and contact ROX Service Center for timely maintenance.
- When the vehicle is stationary, please do not run the range extender system for a long time in a place with deep snow or in snowing.
- The exhaust pipe may have small holes or cracks due to corrosion, damaged joints or abnormal exhaust noise, etc. In this case, do not continue to drive, and contact ROX Service Center.

## 4.2 Child safety

### 4.2.1 Child safety information

#### I. When the child is in the car

1. When traveling with a child under the age of 12 or under 1.5 m in a car, be sure to install a child safety seat or safety seat cushion for the child. Allow the child to sit on the child safety seat or safety seat cushion instead of hugging or sitting on the knee, so as to fully protect the safety of children in the car.
2. For installation details, please strictly follow the manual attached to the child safety seat. This manual provides general installation instructions.
3. Child safety seats should be installed on the rear seats to prevent children from mistakenly touching the shift system, etc., and ensure to have children's seat belts fastened throughout the vehicle.
4. For the sake of safety, install the child safety seat at the second/third row of seats.
5. When children are in the car, please open the rear door child safety lock to avoid children opening the windows or doors while driving.
6. Do not allow children to operate any equipment, such as windows, doors, sunshades, etc., that may jam or clamp the body.
7. Do not leave children in the vehicle alone.

#### II. Forbidden to install child seats in the front passenger seat

Do not install a child seat on the front passenger seat, and avoid children being too close to the airbag. In case a collision, the deployed airbag may cause serious injury or even death to the children.

### Tip

- A warning sign is affixed to the right sunshade, reminding front occupants of the dangers of front airbags. Be sure to read and follow the instructions on the sign.

## 4. Safety instructions



### 4.2.2 Child safety seat

I. Applicable information for child safety seats in different seating positions

Quality group	Seating position				
	Front seats	Second row seat		Third row seat	
		7-seater	6-seater	7-seater	6-seater
Group 0: < 10 kg	x	U	U	x	U
Group 0+: < 13 kg	x	U	U	x	U
Group I: 9 kg ~ 18 kg	x	U	U	x	U
Group II: 15 kg ~ 25 kg	x	U	U	x	U
Group III: 22 kg ~ 36 kg	x	U	U	x	U

Note: The meaning of the letters in the above table:

- U: Applicable to the universal child safety seat approved by the quality group.
- X: This seat is not applicable to the child safety seats of the quality group.

#### Caution

- When using a non-universal child safety seat, please carefully verify the adaptability of the device



## 4. Safety instructions

with the relevant child safety seat manufacturer or such seat retailer.

### II. Applicable information for child safety seats in different seating positions

Quality group	Size type	Fastener	Installation position				
			Front seats	Second row seat		Third row seat	
				7-seater	6-seater	7-seater	6-seater
Portable bed	F	ISO/L1	×	×	×	×	×
	G	ISO/L2	×	×	×	×	×
Group 0: < 10 kg	E	ISO/R1	×	IL	IL	×	IL
Group 0+: < 13 kg	E	ISO/R1	×	IL	IL	×	IL
	D	ISO/R2	×	IL	IL	×	IL
	C	ISO/R3	×	IL	IL	×	×
Group I: 9 kg ~ 18 kg	D	ISO/R2	×	IL	IL	×	IL
	C	ISO/R3	×	IL	IL	×	×
	B	ISO/F2	×	IUF	IUF	×	IUF
	B1	ISO/F2X	×	IUF	IUF	×	IUF
	A	ISO/F3	×	IUF	IUF	×	IUF
Group II: 15 ~ 25 kg	-	-	×	IL	IL	×	IL
Group III: 22 ~ 36 kg	-	-	×	IL	IL	×	IL

Note: Letters in the above table have the following meanings:

- IUF: Applicable to the forward-facing general ISOFIX child restraint system approved by the quality group.
- IL: Applicable to the child safety seats in the list of recommended child safety seats or cars and seats that are included in the list of vehicles recommended by manufacturers of child protective devices
- X: ISOFIX position inapplicable to ISOFIX child safety seats of the quality group or in the size category.

### Caution

- When using a non-universal child safety seat, please carefully verify the adaptability of the device with the relevant child safety seat manufacturer or such seat retailer.

### III. Child safety seat

It is recommended to use intelligent child safety seats. Refer to the following connection method of Babyfirst R542C intelligent child safety seat to connect the intelligent child safety seat: Click "Vehicle Settings → Accessories → Child Seat" through the central control screen to add a Bluetooth child seat.

## 4. Safety instructions

1. When using the child seat, ensure that the Bluetooth of the child seat is turned on. Click “Add Seat” on the child seat interface of the central control screen. Click “Device List” to connect the child seat after searching for a device.

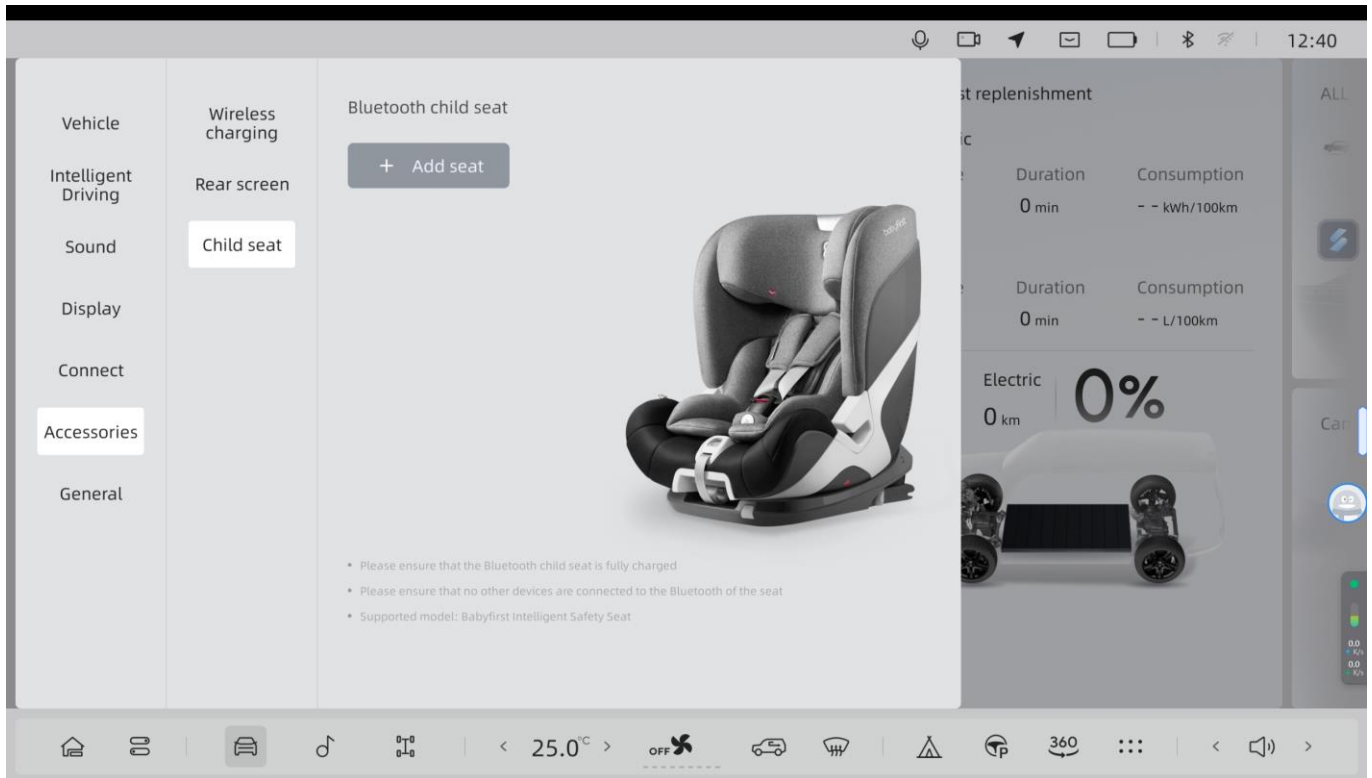

2. After successfully adding a child seat, the child seat interface will display information such as seat connection status and seat power level.

3. If you need to disconnect the connected child seat, first click the connected device, a prompt message will pop up on the central control screen, and then click “Disconnect” to disconnect the connection. If you need to reconnect the child seat, click the device information again to display the status of the child seat.

### ⚠ Caution

- After each restart of the vehicle, the vehicle will not automatically connect the child seat equipment. It needs to be manually reconnected.

4. When installing the child seat, if the ISOFIX fixed anchor is not installed in place, the central control screen will send out a prompt message and an alarm sound after the device is connected. At this time, it is necessary to check and reinstall the child seat. If it is normal after the reinstallation, the prompt message will disappear.

### VI. Fixing methods used for child safety seats

This vehicle provides a variety of fixing methods for the child safety seat. You can choose to use one or multiple methods to fix the child safety seat or cooperate with multiple ways to fix it according to the requirements of the manual attached to the child safety seat.

## 4. Safety instructions

### 1. Fix the seat belt



## 4. Safety instructions

### 2. ISOFIX anchor

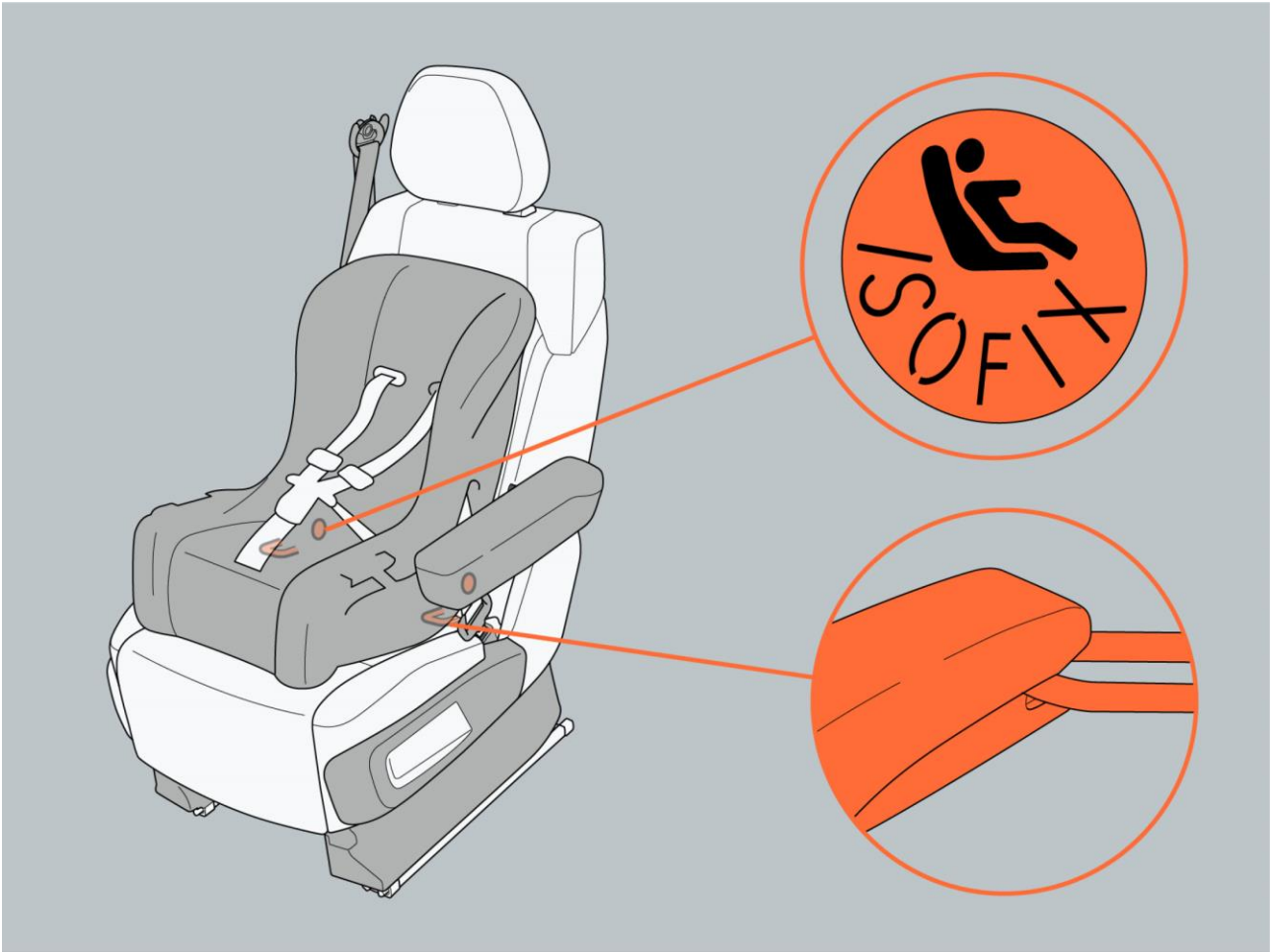

## 4. Safety instructions

### 3. ISOFIX pull-up strap anchor

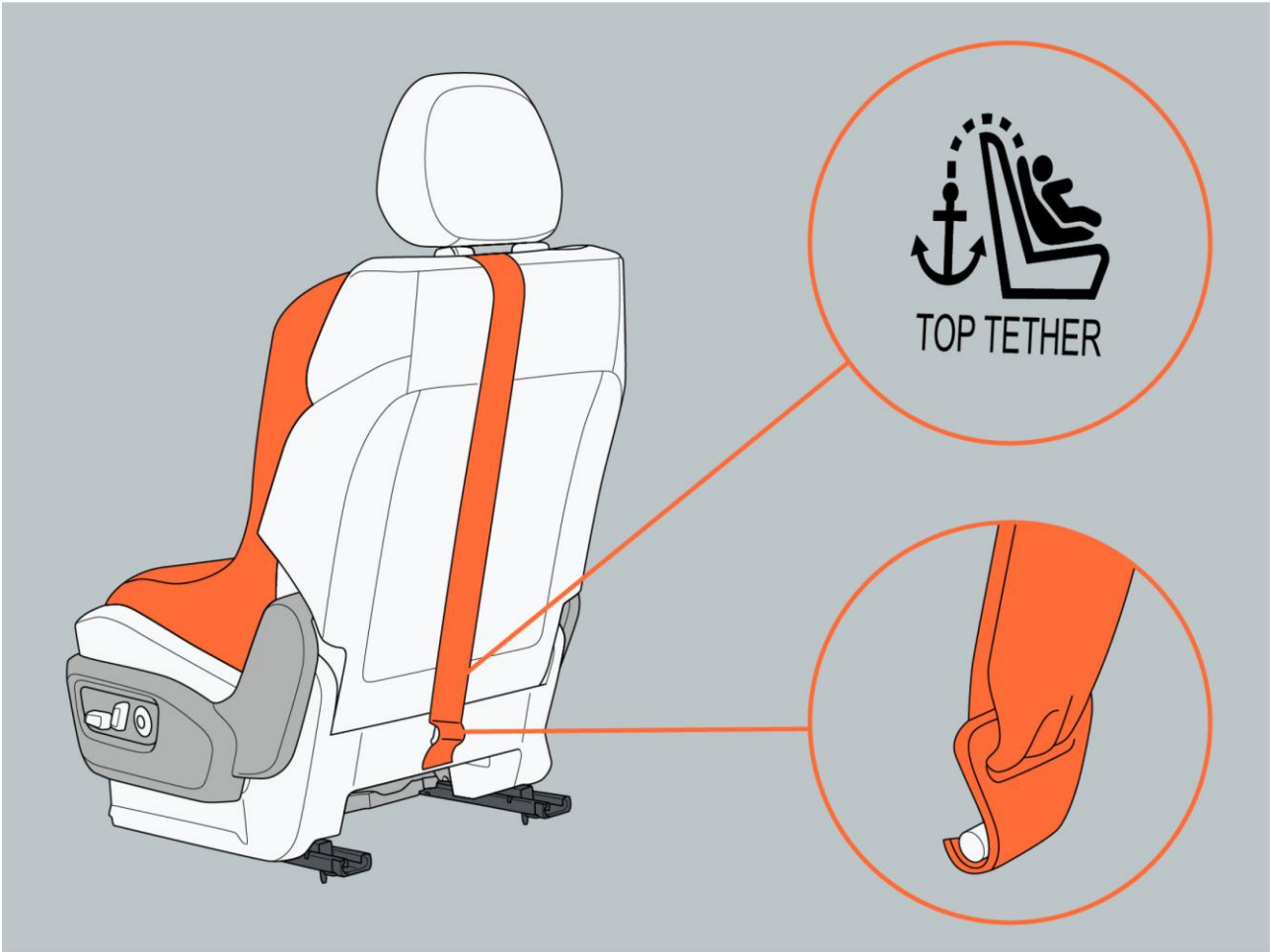

## 4. Safety instructions

### 4.2.3 Installation of child safety seat

It is recommended to use the Globlekids Talent PLUS child safety seat for children weighing no more than 18 kg (approx. 3 years old). When using the child safety seat, the reverse installation method must be used.

Please install the child safety seat according to the manual attached to the child safety seat. This manual provides general installation instructions.

#### I. Install child safety seat with seat belt

1. If the headrest interferes with installation of child safety seat, remove it or raise it to the highest position.
2. Adjust the position of the second-row seat: When installing in the second-row seat, adjust the second-row seat to the rearmost position; When installing in the third-row seat, please adjust the second-row seat to the foremost position.
3. Place the child safety seat facing the front of the vehicle in the second/third-row seat.



## 4. Safety instructions

4. Adjust the backrest angle of the second/third-row seat. The backrest of forward-facing child safety seat must fit as much as possible on the seat backrest.
5. Pass the untwisted seat belt through the child safety seat and insert it in the seat belt buckle.
6. Shake child safety seat to ensure that it is firmly installed.



## 4. Safety instructions

### II. Install child safety seat with ISOFIX anchor

1. If the headrest interferes with installation of child safety seat, remove it or raise it to the highest position.
2. Adjust the position of the second-row seat: When installing in the second-row seat, adjust the second-row seat to the rearmost position; When installing in the third-row seat, please adjust the second-row seat to the foremost position.
3. Connect the ISOFIX connector of the child safety seat to the ISOFIX anchor of the seat and ensure that the ISOFIX connector is firmly secured.

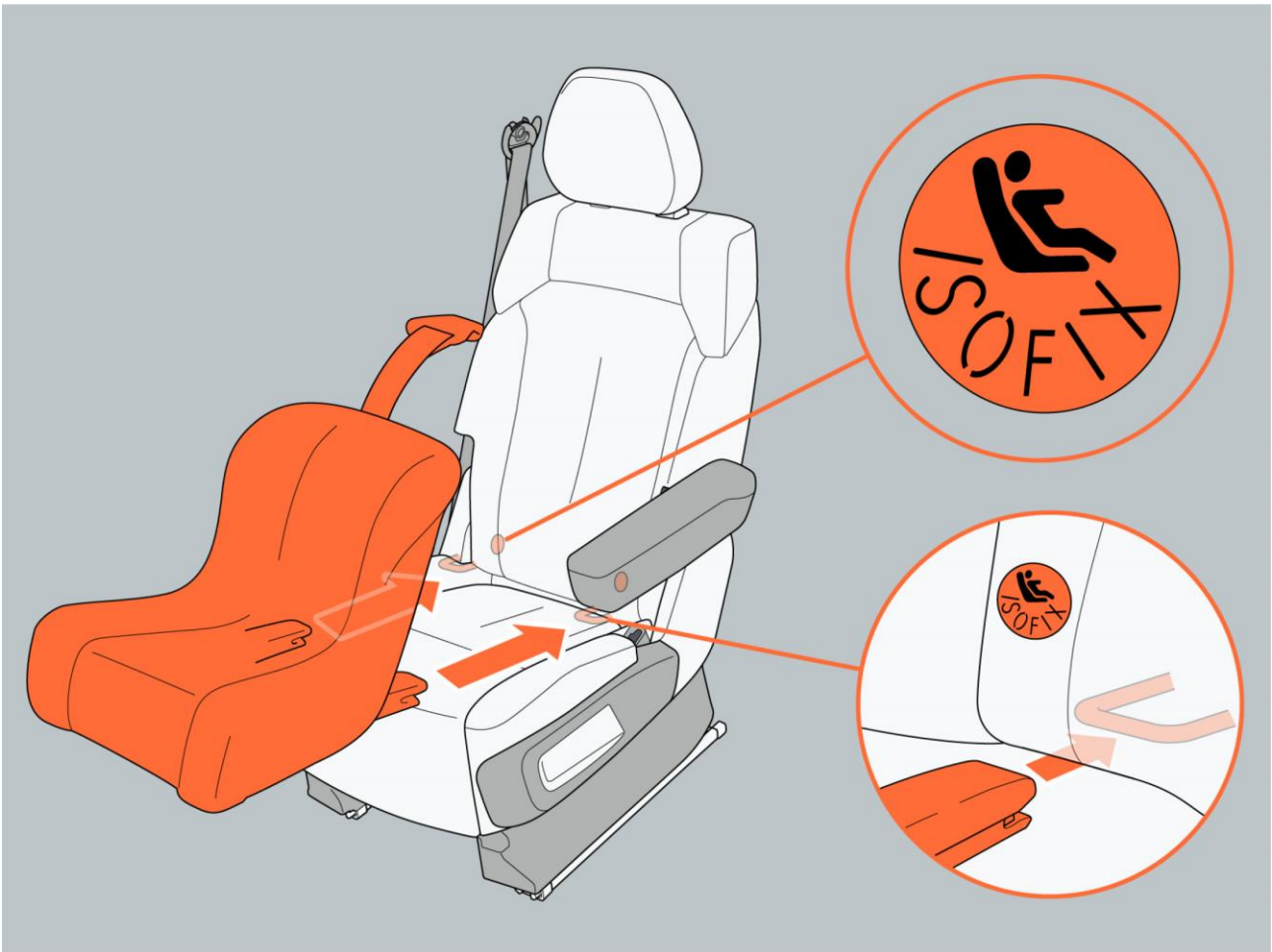

4. Adjust the backrest angle of the second/third-row seat. The backrest facing the front of the child safety seat must fit as much as possible on the seat backrest.
5. Pass the untwisted child safety seat pull-up strap through between the two headrest bars under the headrest and fix it on the ISOFIX pull-up strap anchor. Tighten the pull-up strap of the child safety seat to avoid loosening.
6. Shake child safety seat to ensure that it is firmly installed.



## 4. Safety instructions

### Warning

- Install the child safety seat correctly. Be sure to install the child safety seat according to the installation instructions provided by the manufacturer, so as to prevent the child safety seat from being unable to provide protection the event of an accident.
- After the child seat is installed, do not continue to adjust the seat to avoid displacement of the seat. This would prevent the child safety seat playing its role.

### Caution

- ISOFIX rearward-facing child safety seat can only be installed on the second-row seat.
- For children weighing no more than 18 kg, the child safety seat must be rearward-facing installed.



### 4.2.4 Child safety lock

The rear door of the vehicle is equipped with a child safety lock. After the child safety lock is activated, the corresponding door cannot be opened from the inside. This can prevent children from accidentally opening the door and reduce the risk of car accidents.

## 4. Safety instructions

### I. Activate/deactivate

The child lock key is located at the driver's side window.

Activation: Press the button of the child safety lock, the button indicators up, and the child safety lock is activated.

Deactivation: After the child safety lock is activated, press the child safety lock button, the button indicator goes out, and the child safety lock is deactivated.

#### Caution

- When there are children in the car, please activate the child safety lock.

#### Tip

- After actuating the child safety lock, the door cannot be opened from inside. At this time, unlock and open the door from outside.
- After activating the child safety lock, the corresponding door cannot lift the window.

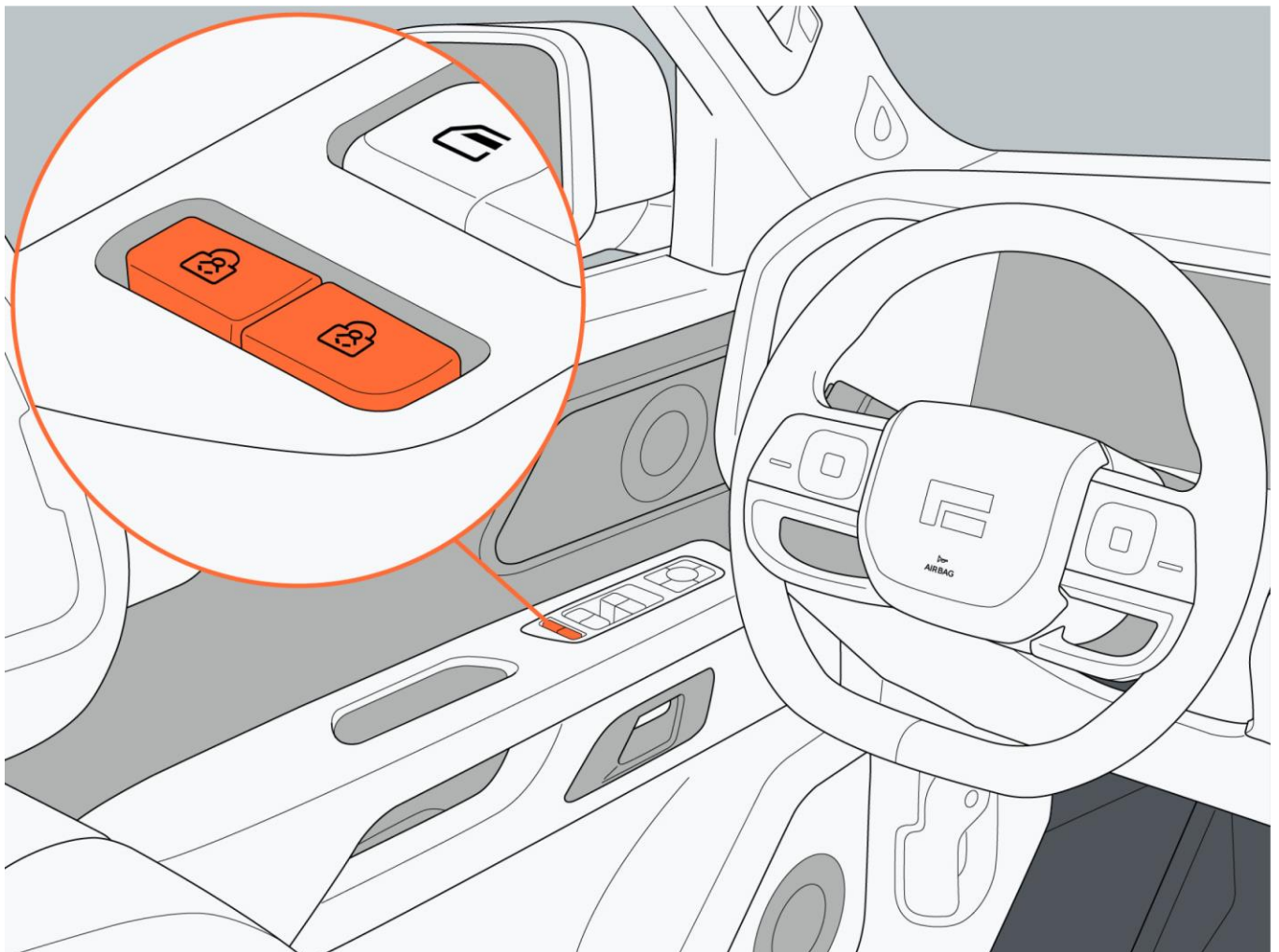

### 4.3 Range extender system

#### 4.3.1 Range extending system feature

Range extend electric vehicles are driven only by motors, not by range extenders. The only function of the range extender is to power the drive motors and the battery.

S/N	Name	S/N	Name
1	Range extender	2	Front drive motor
3	Power battery	4	Rear drive motor

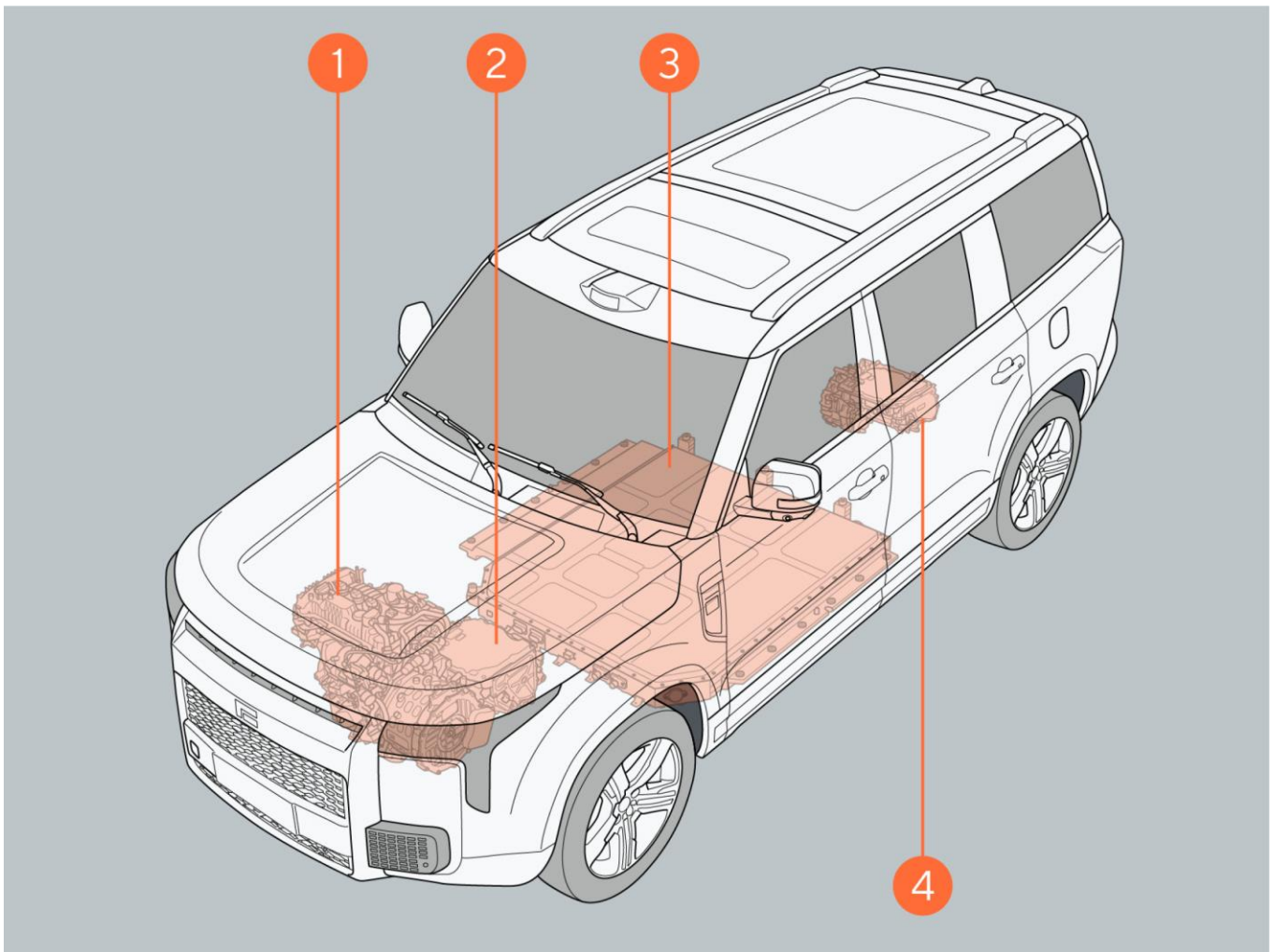

#### I. Energy mode

Three energy modes are provided for this car: pure electric priority, fuel priority and hybrid.

Click the option under “Vehicle Settings → Vehicle → Driving → Energy Mode” through the central control screen to switch the energy mode.

- Pure electric priority: The vehicle gives priority to driving with the energy provided by the power battery. When the power battery level is consumed to a certain value, the range extender will replenish the energy to maintain the appropriate power battery level. After selecting the pure electric priority mode, you can set the ultra-long pure electric function. Turning on the ultra-long

## 4. Safety instructions

pure electric power can use more power battery level and increase the pure electric mileage of the vehicle.

- Fuel priority: When the power battery level is lower than a certain value, the vehicle gives priority to driving with the energy provided by the range extender, which has a high power battery level retention capacity. After selecting the fuel priority mode, you can set the forced power generation function.
- Hybrid: The vehicle intelligently distributes the energy use of the power battery and range extender to maintain an appropriate power battery level.

### Tip

- Low-battery level will weaken the vehicle power. It is not recommended to use the ultra-long pure electric function frequently.
- After activating the forced power generation function, the fuel consumption will increase. It is recommended to use the function when there is a temporary demand for driving charging.
- When the fuel is exhausted or the range extender cannot be started, the power battery will continue to be consumed. Please replenish the fuel in time.

•

### II. Power mode

This car provides four power modes: comfort, standard, sport, and sport+. Users can choose the appropriate power mode according to driving habits. Click the option under “Vehicle Settings → Vehicle → Driving → Power” to switch the power mode.

- Comfort: gentle power response.
- Standard: moderate power response.
- Sport: faster power response.
- Sport+: best dynamic performance and optimum power response.

### 4.3.2 Precautions for range extending

Fuel and power cut-off in case of a collision

In the event of a serious collision accident, the high-voltage power supply system and fuel supply system will be cut off urgently. It can minimize the risk of accident. After a collision and cut-off of power and fuel, the vehicle will not be able to restart. Please contact ROX Service Center in time.

### Warning

- Do not touch the parts of the high voltage system to avoid electric shock.
- Do not touch the fluid leaked from the vehicle to avoid personal injury.
- Do not touch the high-voltage wiring harness exposed in or outside the car to avoid electric shock.
- Keep away from a burning vehicle.

### 4.4 Anti-theft system

#### 4.4.1 Anti-theft system

If the anti-theft system is enabled, when the vehicle is detected to be abnormally invaded, the vehicle will enter the anti-theft alarm state. At this time, the turn signal light flashes and the horn continues to sound for 30 s. If it is re-triggered during the alarm process, it will still last for 30s. If it is triggered again after the alarm is ended, the turn signal light will continue to flash and the horn will continue to sound for 30s. It can be repeated 10 times in an anti-theft cycle.

##### I. Enable anti-theft mode

Lock the vehicle from outside with the doors, trunk doors and hood closed, and the anti-theft system will be enabled. Or after unlocking the vehicle, if the door or trunk door is not opened within 30 s, the door will be automatically locked. At the same time, the anti-theft system will be enabled.

##### II. Trigger an alarm

When the anti-theft system is enabled, an alarm will be triggered when:

- Opening any door, hood or trunk door without a remote key.
- Opening the door without carrying a legal key.

##### III. Shut down the anti-theft system

Any of the following will shut down the anti-theft system:

- Unlock the door with the remote key.
- The vehicle is in "READY" mode.

#### Warning

- Do not modify the remote key without authorization to avoid that the remote key cannot unlock/lock the vehicle.
- When leaving the vehicle, do not leave the remote key in the vehicle. Otherwise, you may not be able to lock the vehicle.
- When locking the vehicle, do not leave children or pests in the vehicle alone.

# 5. Information display

## 5.1 Instrument and central control system

### 5.1.1 Instrument screen

#### 5.1.1.1 Instrument screen overview

S/N	Name	S/N	Name
1	Energy mode	2	Remaining battery mileage
3	Remaining fuel mileage	4	Endurance condition display
5	Warning light and indicator	6	Tire pressure

#### 1. Energy mode

Display the current energy mode: pure electric priority, fuel priority, and hybrid.

#### 2. Remaining battery mileage

Display the possible mileage with the current remaining battery mileage.

#### 3. Remaining fuel mileage

Display the possible mileage with the current remaining fuel.

#### 4. Endurance display condition

Display the current endurance display condition: WLTC, CLTC.

#### 5. Warning light and indicator light

Through the warning lights and indicators displayed on the instrument screen, the working status of each system is displayed for the driver.

#### 6. Tire pressure

The tire pressure information is displayed on the instrument screen. If the tire has abnormal conditions such as low pressure, high pressure, rapid deflation and high temperature, the tire pressure system warning light is on, indicating the corresponding wheel display is abnormal.

S/N	Name	S/N	Name
1	Turn signal light	2	READY indicator
3	Vehicle gear	4	Vehicle speed
5	Driving mode	6	Driving mileage

#### 1. Turn signal light

It will display when turning on the turn signal light or hazard warning light.

#### 2. READY indicator

Indicate that the vehicle is in a drivable status.

#### 3. Vehicle gear

Display the current vehicle gear information: P, R, N, and D.

#### 4. Vehicle speed

Display the current speed information.

## 5. Information display

### 5. Driving mode

Display the current driving mode: Comfort, Standard, Sport, Sport+, Snow, Mud, Rock, Sand, Wade.

### 6. Driving mileage

Display the current mileage of the vehicle.

#### 5.1.1.2 Warning light and indicator

##### I. Indicator

Illustration	Name
	Left turn signal
	Right turn signal
	Hazard
	Position light
	Rear fog lamp
	Low-beam headlamp
	High-beam headlamp
	Automatic high-beam headlamp
	Anti-theft authentication fault
	Electronic handbrake brake
	Hill descent control
	AutoHold
	READY
	Charger connecting status
	Low fuel indicator
	Low power battery level
	ACC-to-be-activated
	LCC-to-be-activated
	Excessive slope indicator
	Press the brake pedal
	Road icing
	Door ajar
	Traction mode indicator light



## 5. Information display

	Trailer mode indicator light
---	------------------------------

### II. Warning light

Illustration	Name
	Brake system fault and low brake fluid level
	Lighting system fault
	Emission system fault
	Airbag system fault
	Low oil pressure
	ABS system fault
	EBD system fault
	Electronic handbrake fault
	Serious power system fault
	Power system general fault
	Limited drive system power
	Drive motor over-temperature
	Drive motor fault
	Low battery power level and battery system fault
	Power battery over-temperature
	High-voltage disconnection
	Battery heat diffusion
	Seat belt not wearing
	Wading
	Range extender maintenance self-starting
	Abnormal tire pressure and temperature and tire pressure monitoring system fault
	Thermal management system
	ESP system fault
	Hill descent control fault
	Shock absorbing system fault
	Sensing unit fault
	Navigation function fault
	PDC system fault



## 5. Information display

	APA system fault
	AVM system fault
	HAVP system fault
	BSD function fault
	RCW system fault
	FCTA system fault
	DVR fault
	DMS system fault
	AutoHold system fault

Note: When the above warning light appears, contact ROX Service Center in time.

### 5.1.2 Central control screen

#### 5.1.2.1 Central control screen overview

S/N	Name
1	Status bar
2	Bottom function bar

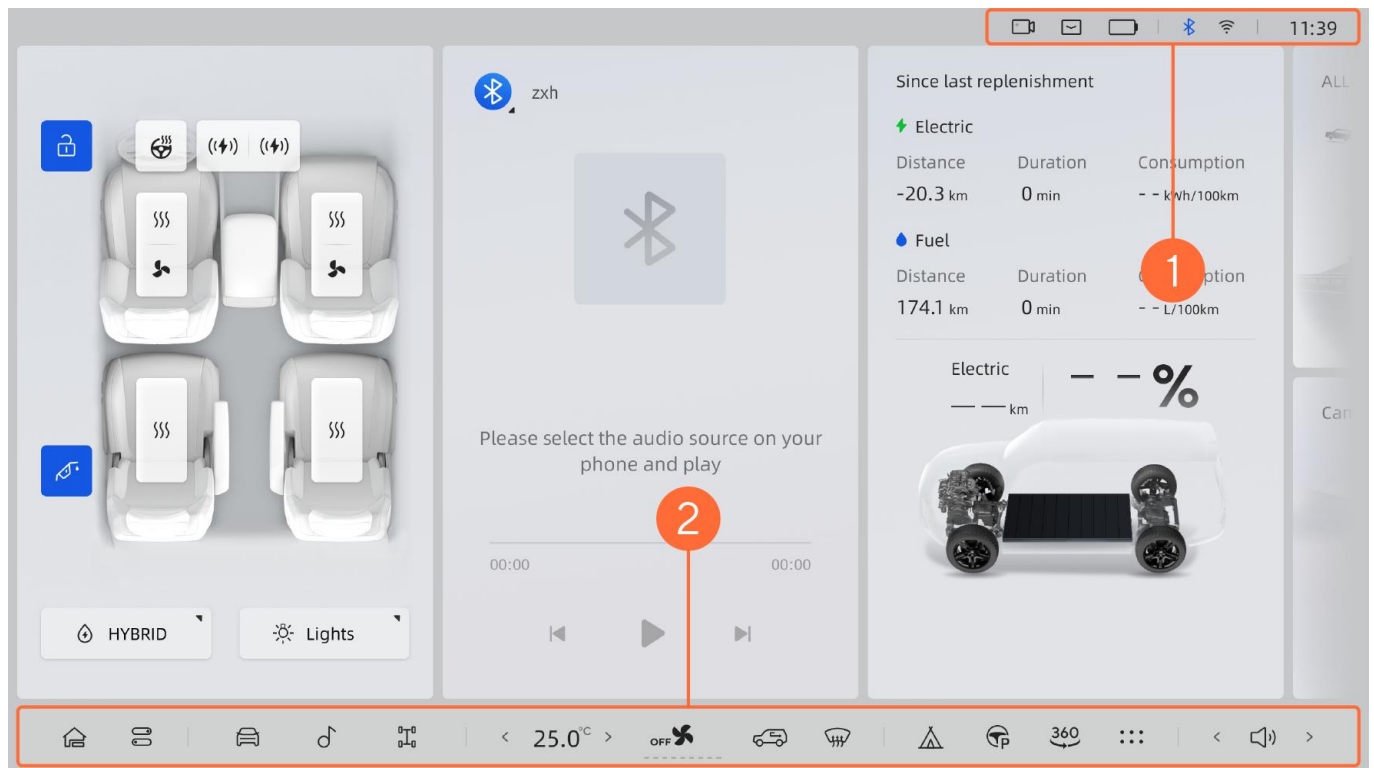

# 5. Information display

## I. Bottom function bar

S/N	Name	S/N	Name
1	Home page	2	Integrated control panel
3	Vehicle setting	4	Music
5	ROX Mode		

### 1. Home page

In other interfaces, click Icon 1 to return to the main interface of the central control screen.

### 2. Integrated control panel

Click Icon 2 to open the integrated control panel, and you can quickly select functions on the integrated control card.

### 3. Vehicle setting

Click Icon 3 to enter the vehicle settings interface.

### 4. Music

Click Icon 4 to enter the music interface.

### 5. ROX Mode

Click Icon 5 to enter the ROX Mode, and you can choose the driving mode according to different road conditions.

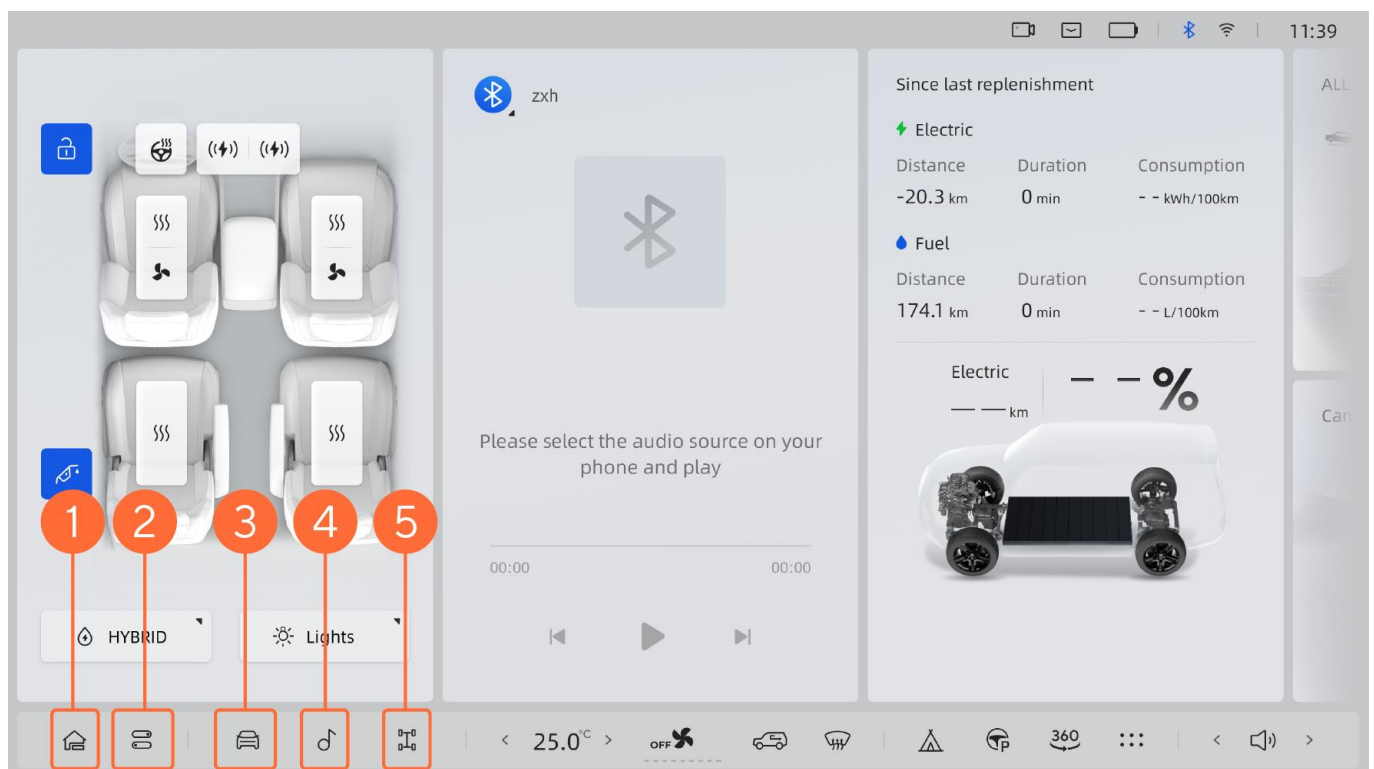

## 5. Information display

S/N	Name	S/N	Name
6	Adjustment of air conditioners	7	Windshield defogging
8	Camping mode	9	Automatic parking assist
10	Around view monitoring	11	Application center
12	Multimedia volume control		

### 6. Adjustment of air conditioners

Click Icon 6 to enter the A/C system control interface or adjust the A/C.

### 7. Windshield defogging

Click Icon 7 to turn on the windshield defogging system. Click again to turn off the windshields defogging system.

### 8. Camping mode

Click Icon 8 to turn on camping mode.

### 9. Automatic parking assist

Click Icon 9 to enter the APA control interface.

### 10. Around view monitoring

Click Icon 10 to enter the 360 image, which provides a panoramic view of the surroundings of the vehicle, including the front, rear, and side views.

### 11. Application center

Click Icon 11 to enter the application center.

### 12. Multimedia volume control

Click left and right to adjust the multimedia volume.

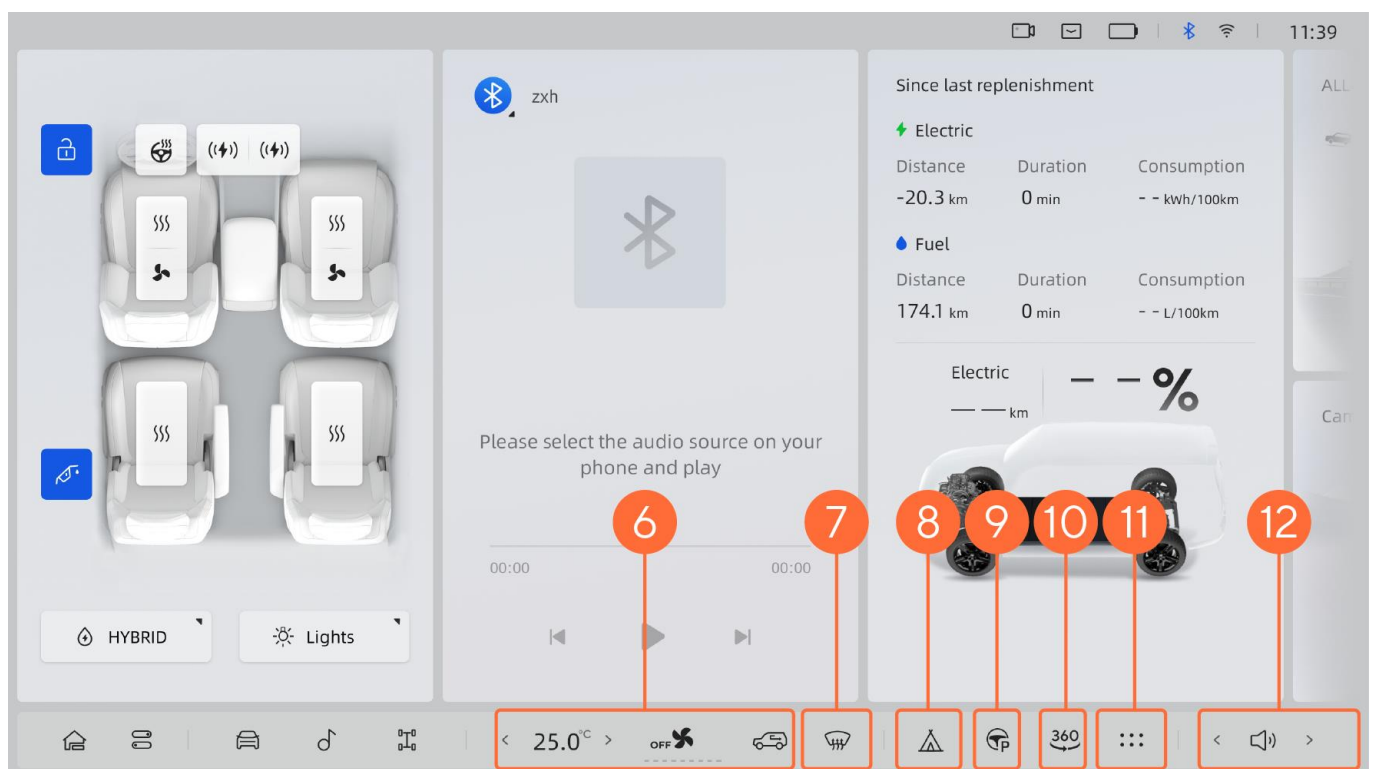

## 5. Information display

### II. Status bar

The status bar displays information such as time, network signal, driver account, Bluetooth connection status, and call status.

#### 5.1.2.2 Integrated control panel

S/N	Name	S/N	Name
1	Memory position	2	Ceiling screen settings
3	Screen off	4	Screen cleaning
5	Multimedia volume	6	One-touch sport

S/N	Name	S/N	Name
1	Nap mode	2	Low speed driving sound
3	Power-on when leaving	4	Stealth mode
5	Brightness adjustment		

## 6.1 Key information

### 6.1.1 Key

This vehicle is equipped with the following keys:

1. Remote key.
2. Mechanical key.

#### **i** Tip

- If you need to match the key, please consult ROX Service Center.

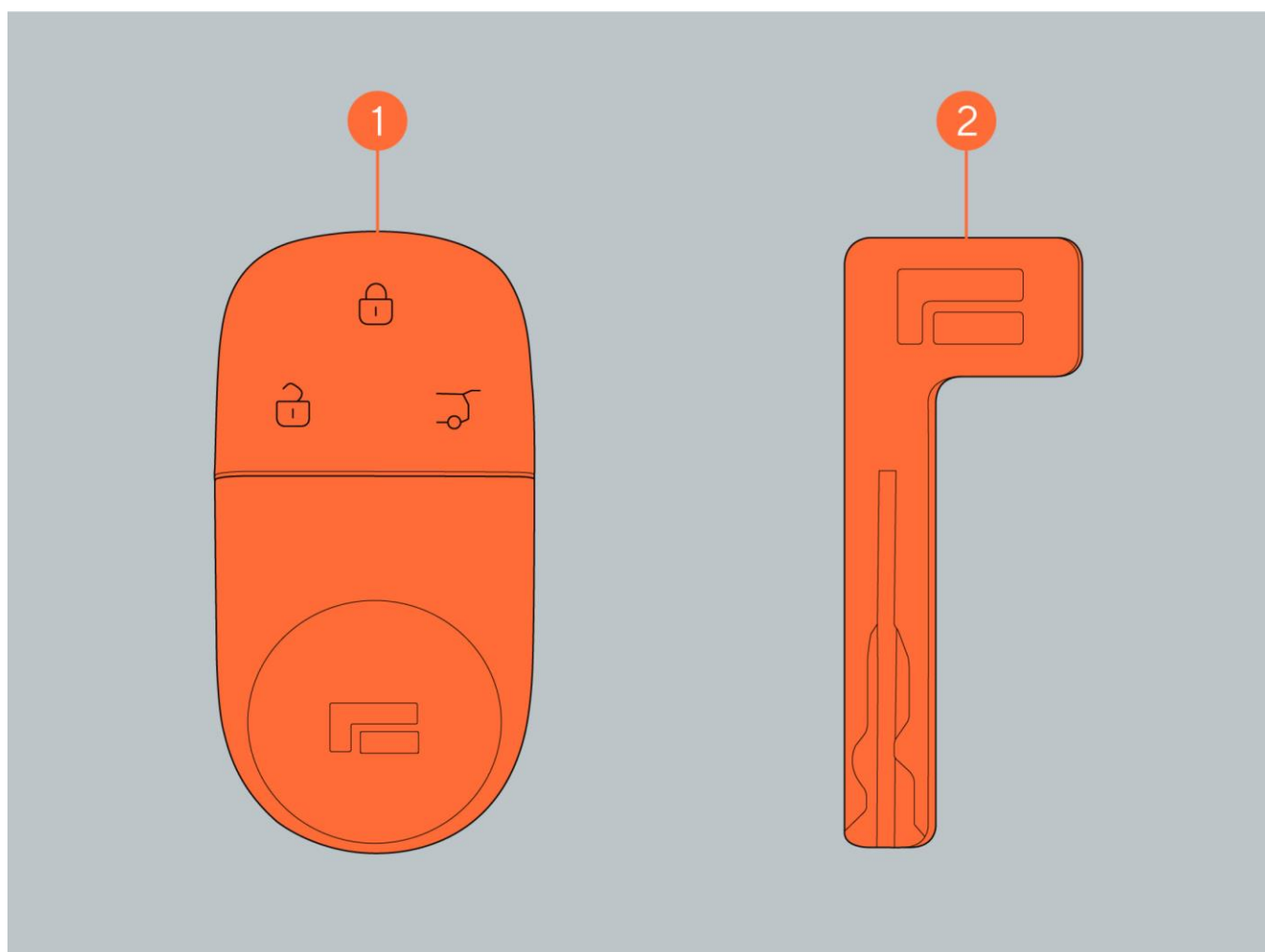

### 6.1.2 Remote key

I. Remote key

1. Unlock button.
2. Locking button.
3. Trunk door control button.

#### **!** Caution

- When getting out of the car, please carry all the remote keys with you. Otherwise the remote keys

## 6. Operation

may be locked in the car.

- The remote key is affected by electronic equipment (such as mobile phones, computers, etc.), magnetic substances, and the electromagnetic environment around the vehicle. The key signal may be interfered, resulting in temporary failure of the key function or unstable operation.
- The remote control key is an electronic component. Prevent it from knocking, disassembling or placing in high temperature, humidity and strong vibration environment.
- Do not leave the remote key in the vehicle. It may not be locked in the car by mistake.
- Do not place the remote key in the trunk. It may indicate that the fob cannot be found and cause the vehicle to fail to start.

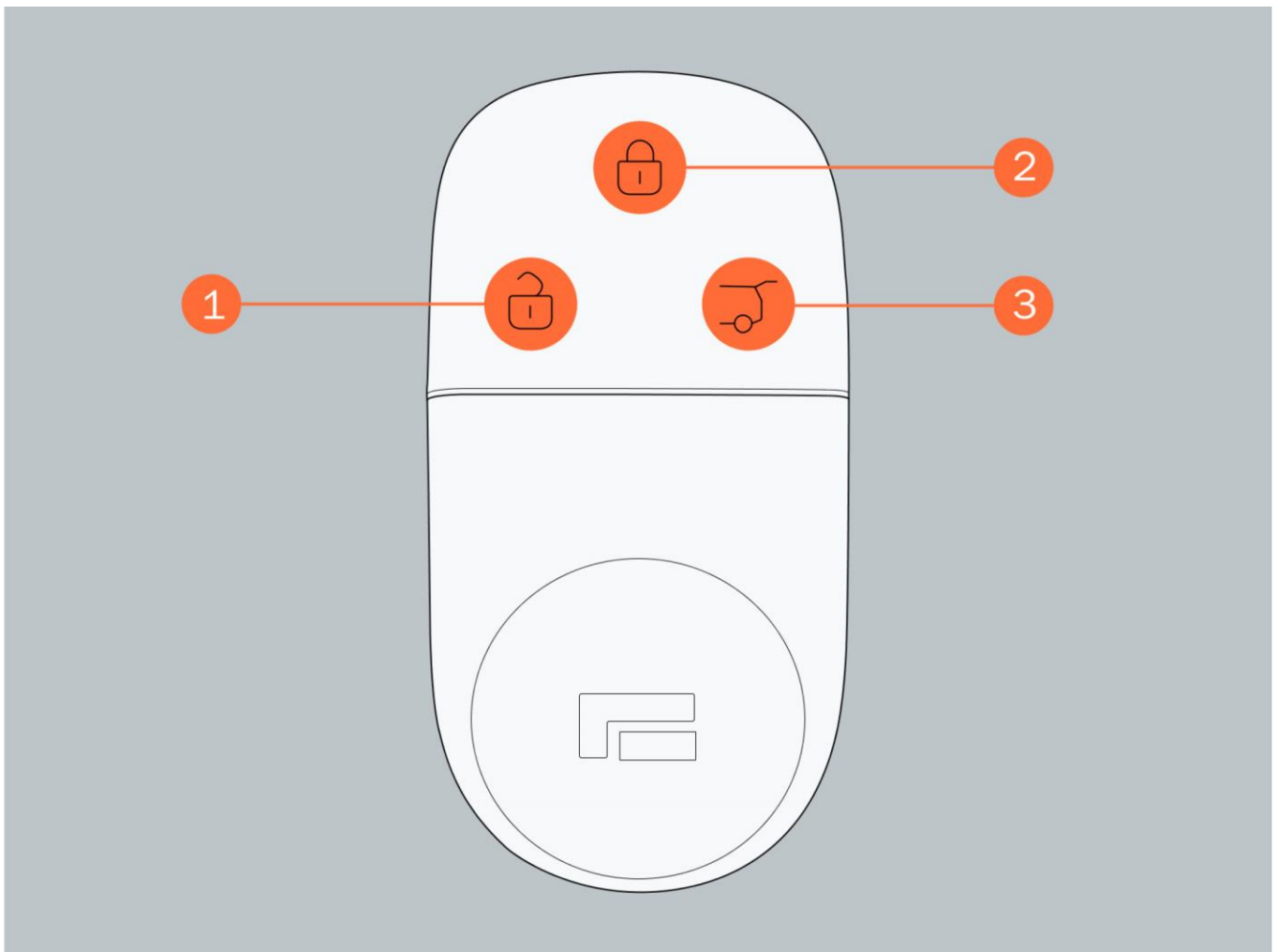

### II. Car locating

Activate the car locating function, press the lock button twice continuously in 2 s within the effective mileage, the turn signal light and low beam flash, and the vehicle honks. During the process of locating the car and honking the horn, unlock the vehicle to stop locating. Activate/deactivate the car locating system through the central control screen.

### III. Door ajar reminder

When the vehicle is locked, if any door, trunk door, hood or refueling cover is not closed, the horn will sound an alarm.

### IV. Depletion of remote battery power

If the battery power of the remote key is low, the instrument screen will display a prompt message of “low key power” .

Even if the key is not used, the remote key battery will be depleted. The key power may be depleted. If necessary, please replace the remote key battery if:

- The vehicle cannot start or the remote key function cannot be used normally, or
- Detection area becomes smaller

### V. Electromagnetic interference

The remote key receives strong electromagnetic waves for a long time. It is likely to cause the rapid depletion of the battery power. Do not place it near an electrical device that can create a magnetic field, such as:

- TV sets.
- PCs.
- Mobile phones and chargers.
- Table lamps.
- Electromagnetic ovens.

### Warning

- Do not place the remote control battery near electrical equipment that can generate magnetic fields for a long time, such as computers, electromagnetic ovens, TV sets, etc.
- Do not expose the remote key to high or low temperature for a long time.
- Do not place the remote key near or in contact with metal or magnetic materials.
- Do not change or increase the transmission power of the antenna without authorization.
- Do not connect external antennas or use other antennas without authorization.
- Do not disassemble the remote key without authorization.

## 6.1.3 Keyless entry and start system

### I. Keyless entry

Unlock or lock the door with the remote key.

### II. Keyless start

Carry the remote key, press the brake pedal, and the “READY” indicator on the instrument screen is on. At this time, the vehicle is drivable.

### III. Antenna position (subject to the real vehicle)

S/N	Name	S/N	Name
1	Vehicle exterior antenna	2	Vehicle interior antenna

## 6. Operation

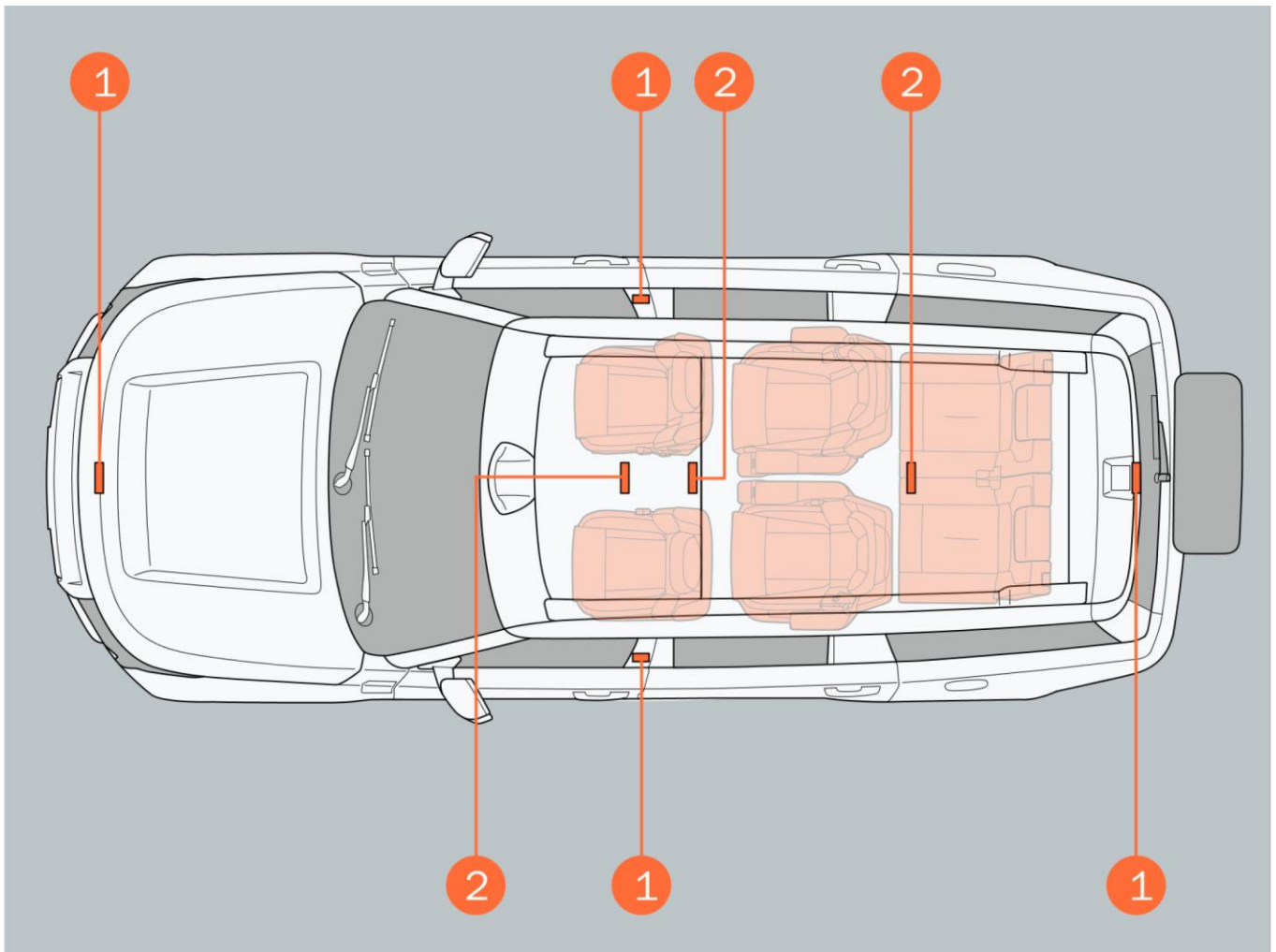

IV. Effective mileage (area where the remote key can be detected)

1. Start the vehicle

When the remote key is placed in the vehicle, you can start the vehicle.

2. Unlock or lock the door

With the remote key in the effective mileage, you can unlock/lock any side door (only the door where the key is detected can be operated).

3. Welcome function

With the remote key in the effective mileage, the welcome function can be triggered. The vehicle will make corresponding welcome actions according to the content set by the user.



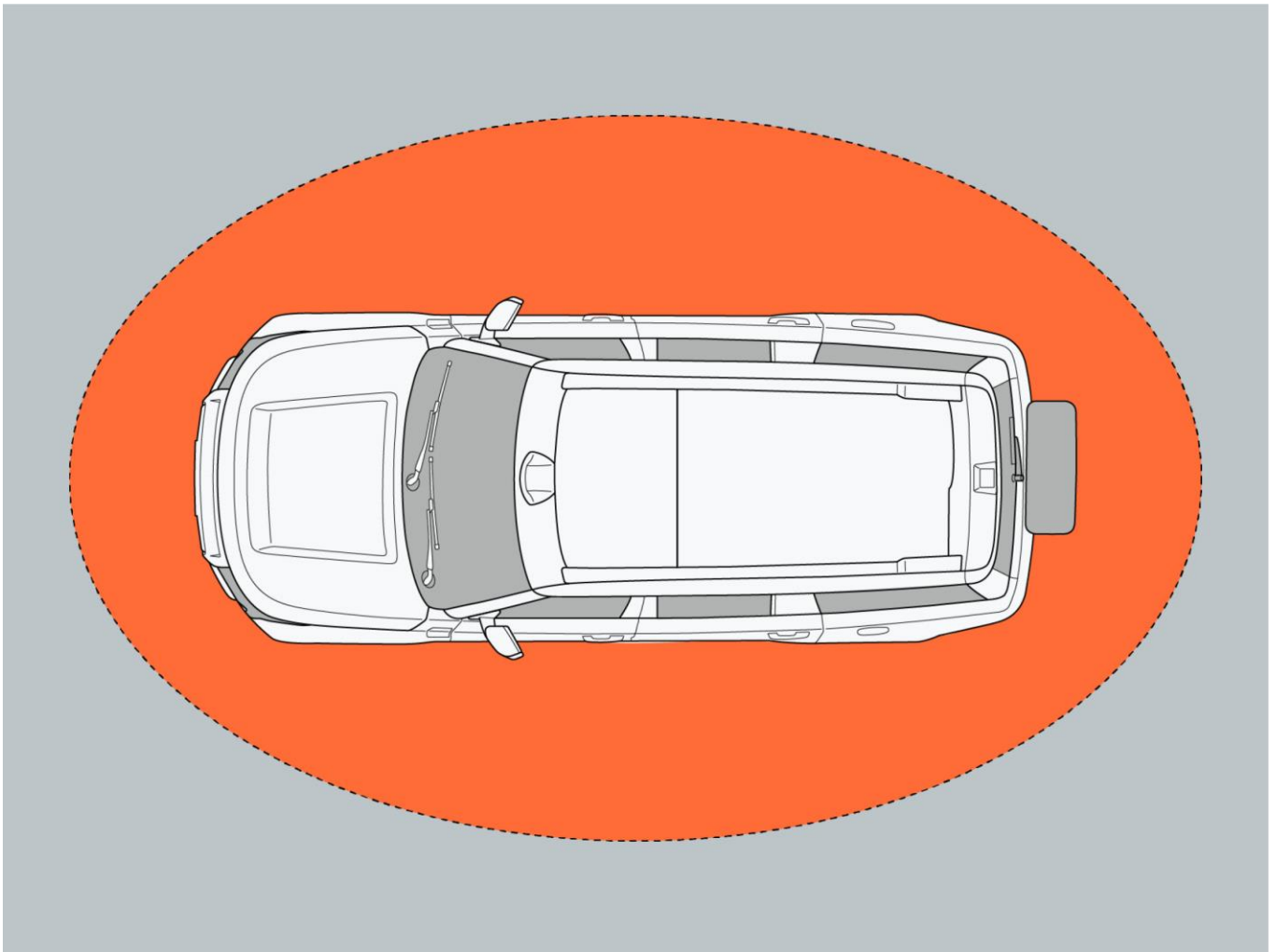

### 4. Open trunk door

With the remote key in the effective mileage of the external antenna at the trunk door, press the trunk door unlock button with the remote key to release the electricity and manually open the trunk door.

## 6. Operation

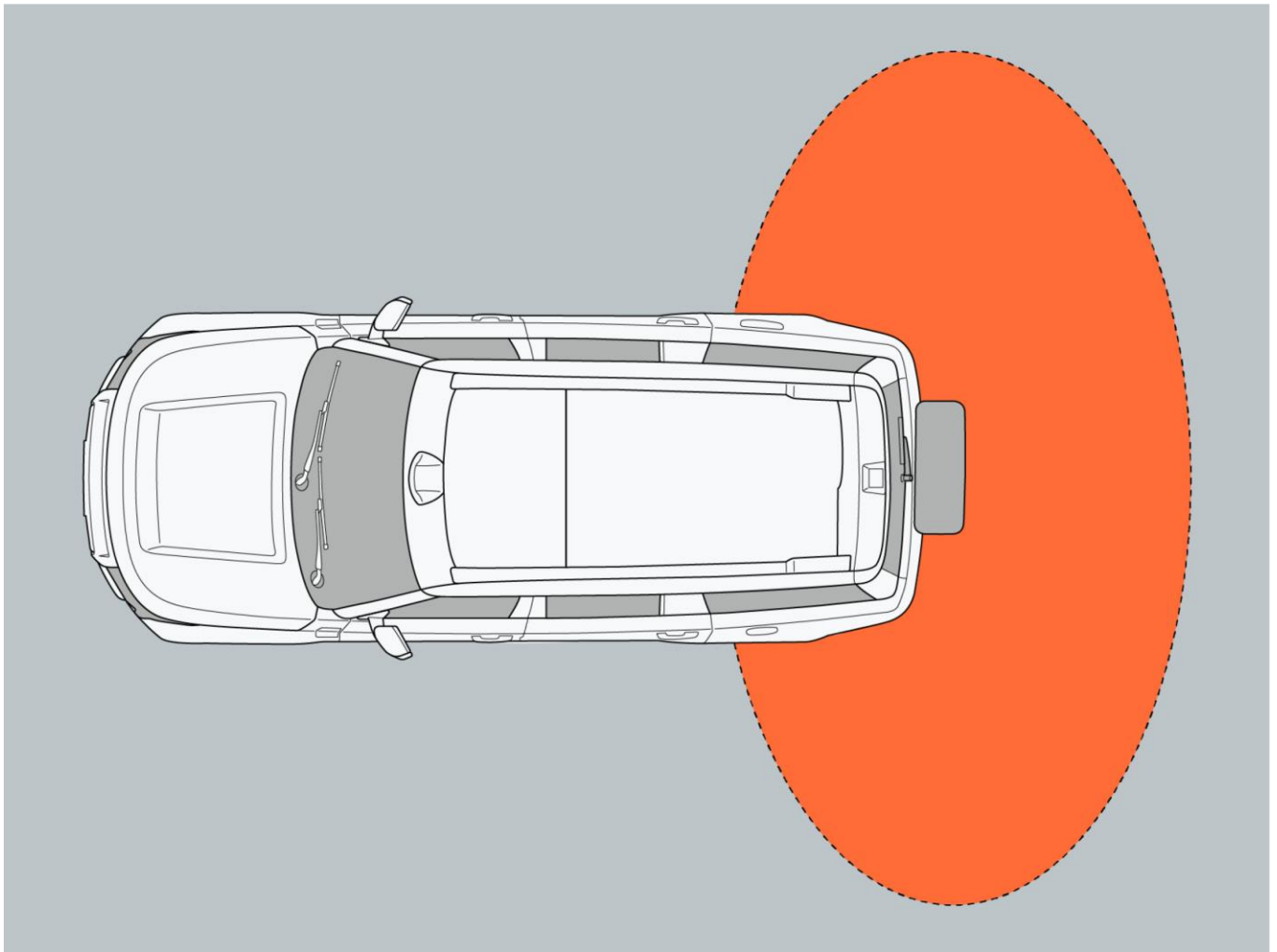

### V. Conditions affecting use

Communication between the remote key and the vehicle may be affected, thereby hampering the keyless entry function, the keyless start system, the remote key and the anti-theft system if:

- The remote key is in contact with or covered by metal objects.
- The remote battery power is depleted.
- The remote key is exposed to high or low temperature for a long time.
- The remote key is placed near the battery, charger, or other electronic device.
- It is close to television towers, power plants, petrol stations, radio stations, airports or other facilities that generate strong radio waves.
- The remote key is placed with a magnetic card (e.g. bus card, bank card, etc.).
- A film or metal object containing metal components is adhered to the window.
- Use other remote key near the vehicle.

### VI. Precautions for keyless entry

- Anyone can unlock/lock any door as long as the remote key is in the effective mileage. However, only doors with a detected remote key can be used to unlock/lock the vehicle.
- If the inductive sensor contact with ice, snow, mud, etc., it may not work properly. Please clean the sensor, and try to unlock or lock the door again.

## 6. Operation

- If there is another remote key in the detection area, it may delay unlocking/locking the vehicle.
- When the remote key is in the effective mileage, it may also unlock/lock the door if there is a large amount of water splashing on the door handle (such as raining or washing car).
- If you touch the door handle sensor while wearing gloves, the unlock/lock operation may be delayed or blocked.

### VII. Remote key failure

Unlock/ lock the door with the mechanic key.

### VIII. Parking vehicle for a long time

Do not place the remote key close to the vehicle to avoid theft of the vehicle.

## 6. Operation

### 6.2 Opening, closing and locking door

#### 6.2.1 Doors

I. Open and close the door

1. Open/close the door from outside

Open: After the vehicle is unlocked, pull the outside door handle to open the door.

Close: Push the door toward the inside until the door is closed in place.

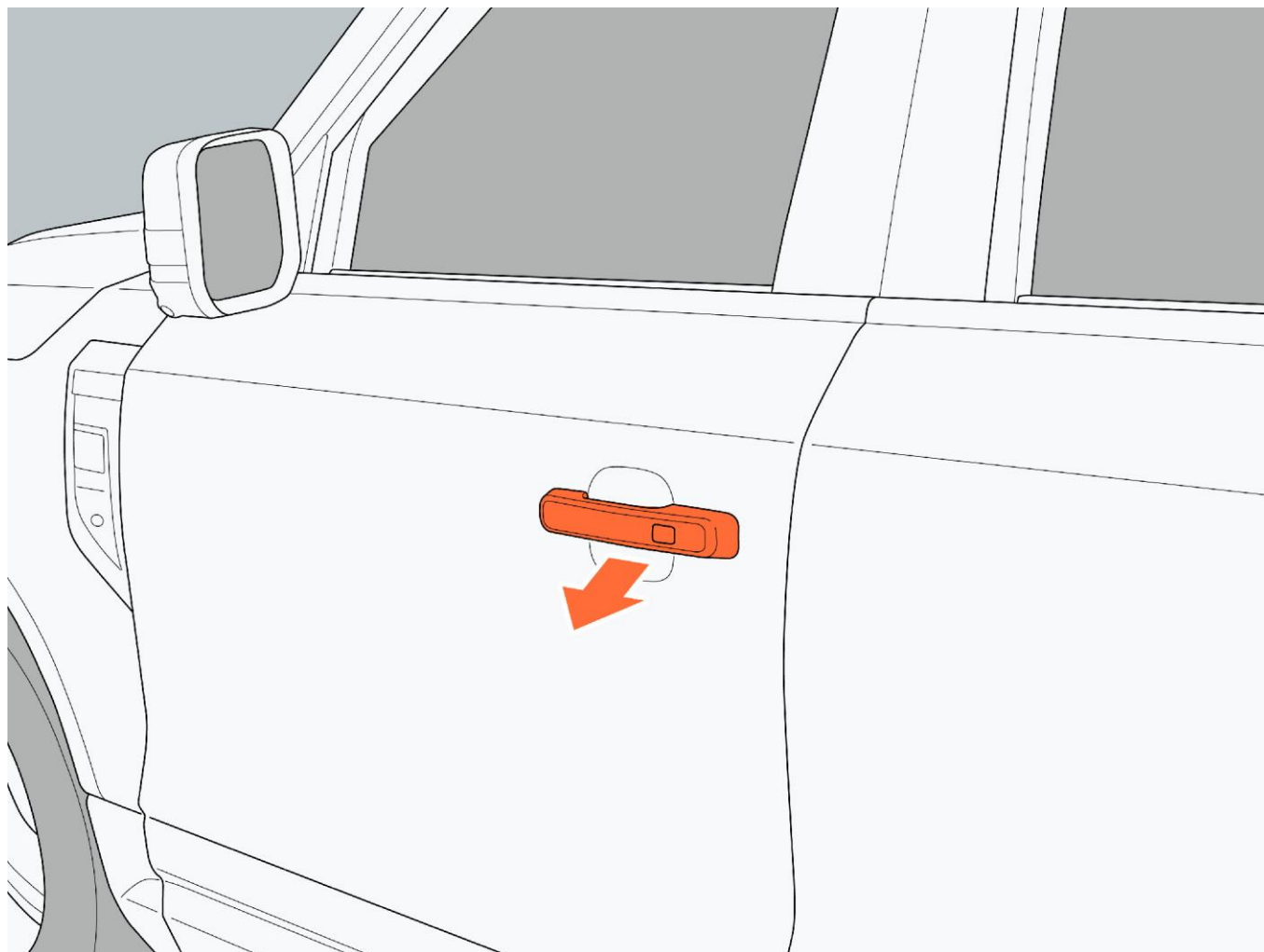

2. Open/close the door from inside

Open: When the door is unlocked, pull the inside door handle to push outward to open the door.

Close: Pull the door toward the inside until the door is closed in place.

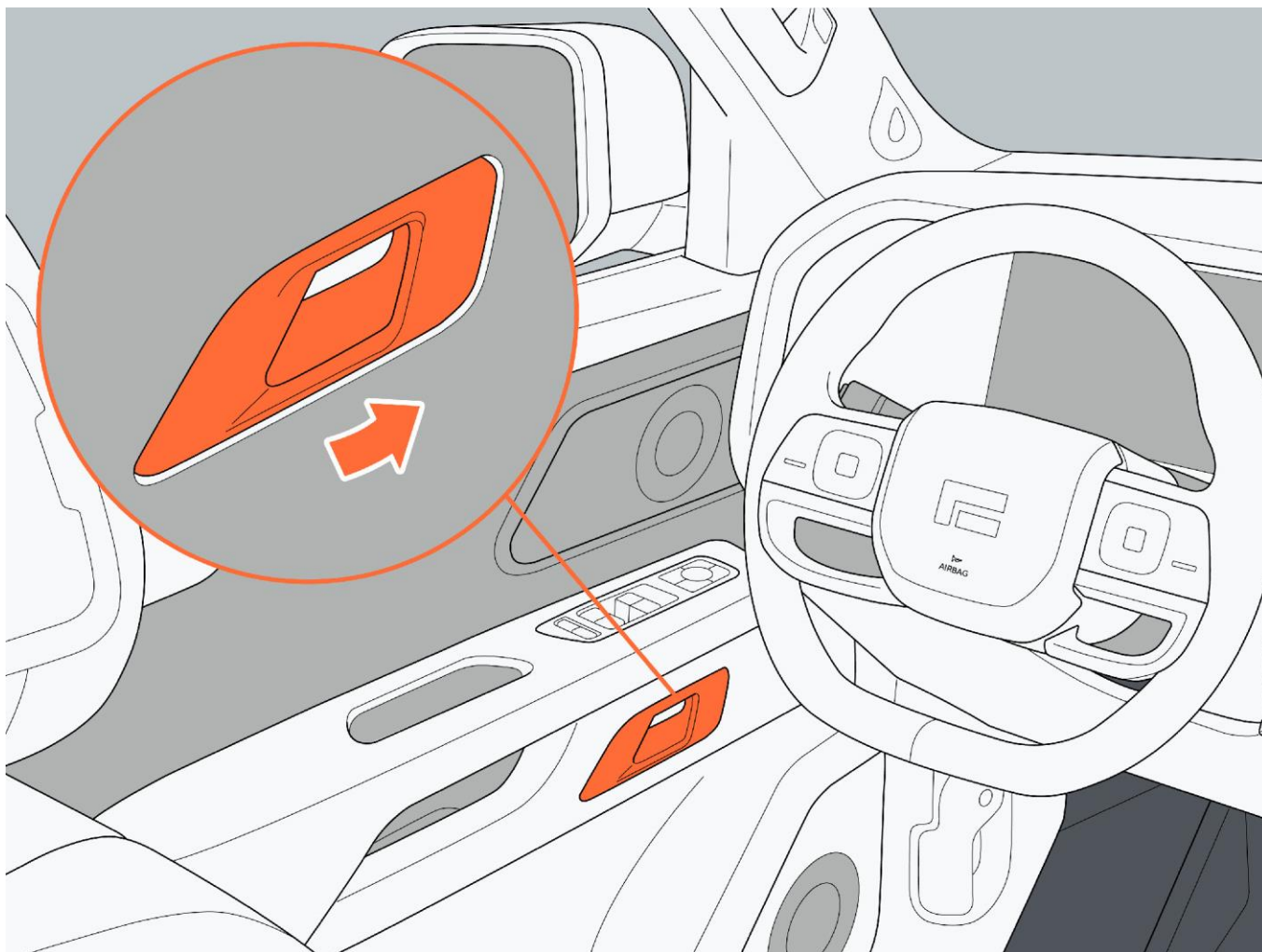

## II. Unlock/lock the door

When the door is unlocked from outside, the exterior rearview mirror automatically unfolds. When the door is locked from outside, the exterior rearview mirror automatically folds.

### 1. Unlock/ lock the door with the remote key

Unlock: When the vehicle is in a locked state, press the remote key unlock button 1 within the effective mileage to unlock all doors.

Lock: When the vehicle is in an unlocked state and all doors, hood and trunk doors are closed, press the remote key lock button 2 within the effective mileage to lock all doors.

#### **i** Tip

- When the vehicle power is in "READY" mode, the remote key unlock/lock door function will not work.

## 6. Operation

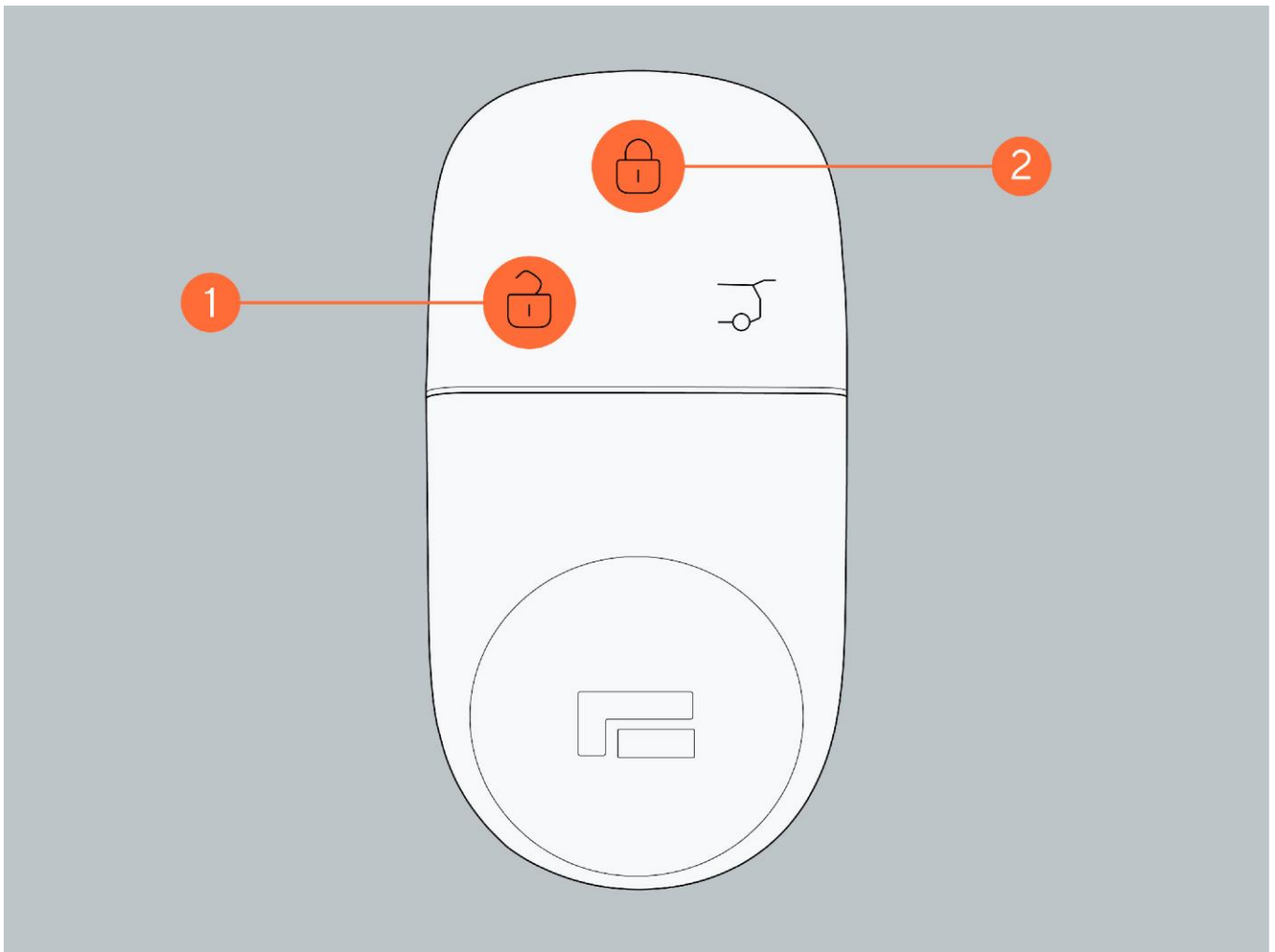

### 2. Unlock/ lock the door by keyless entry

Unlock the door:

- When the central control screen is set to only unlock the driver door, press the unlocking area on the inner surface of the driver's side door handle with carrying the remote key or Bluetooth key, to unlock the driver's side door. Touch the unlocking area on the inner surface of the driver's side outer handle to unlock the car. Press the unlocking area on the inner side of other door handle with carrying the remote key or Bluetooth key to unlock the car.
- When the central control screen is set to unlock the car, press the unlocking area inside the door handle on either side the remote control key or Bluetooth key to unlock the car.

Lock the door: When the vehicle is in an unlocked state and all doors, hood and trunk doors are closed, press the outside door handle sensor area with the Bluetooth key or remote key to lock all doors.

#### **i** Tip

- If the remote key is in the car, the door cannot be unlocked/locked by touching the door handle sensor area.

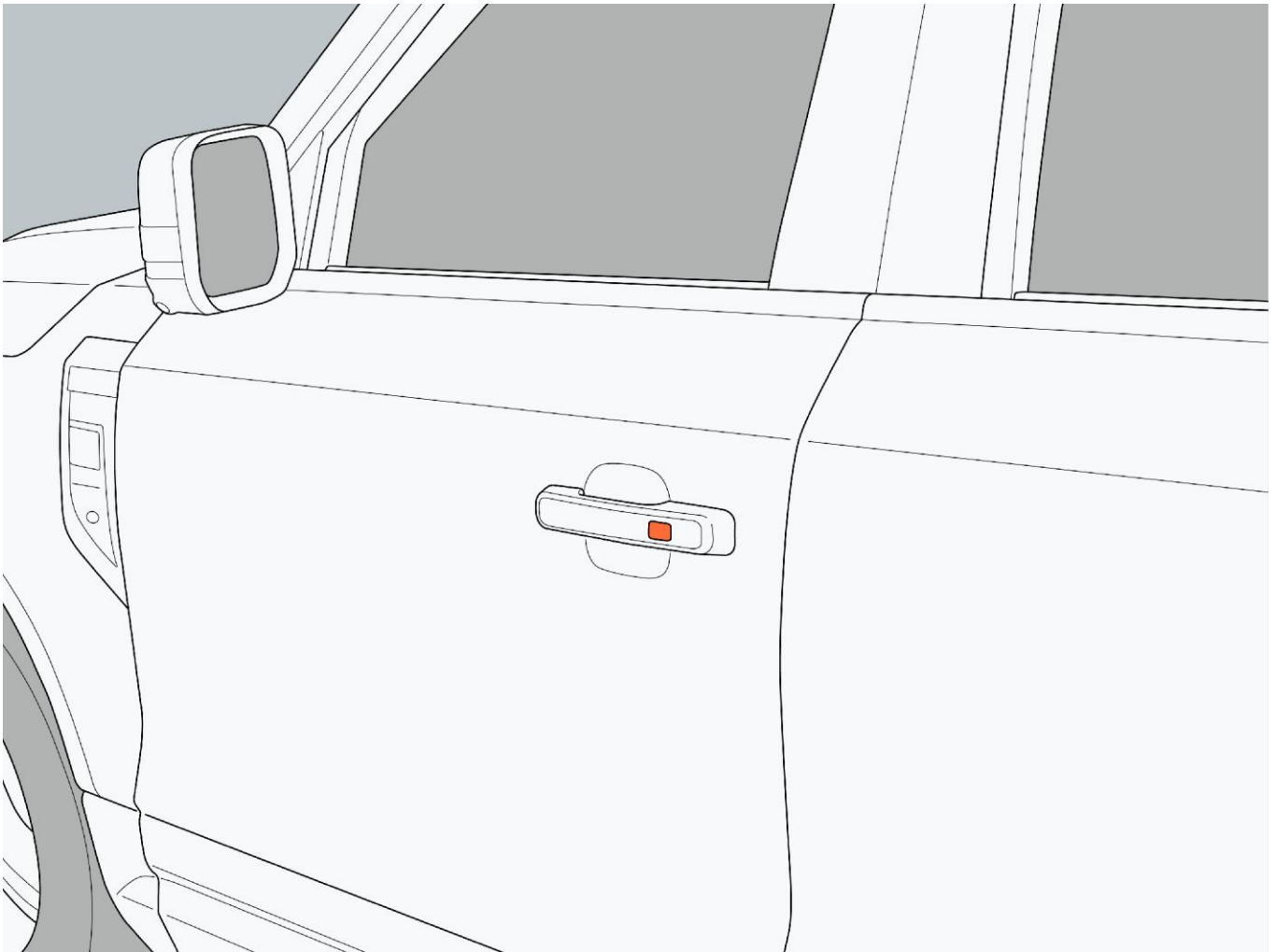

### 3. Unlock the door when approaching/lock the door when leaving

Click “Vehicle Settings → Vehicle → Door Lock → Auto-Lock When Leaving” through the central control screen, to set the activation and deactivation of unlock door when approaching/lock door when leaving.

Unlock: With the vehicle locked, approach the vehicle with carrying the remote key or Bluetooth key. All doors are unlocked automatically.

Lock: When the vehicle is in an unlocked state and all doors, hood and trunk doors are closed, all doors are locked automatically after leaving the vehicle for more than a certain distance with carrying the remote key or Bluetooth key.

#### **i** Tip

- If either door is not properly closed, there is a remote key in the car, the seat is occupied, or the camping mode is activated, the locking after leaving function will not work.
- In order to prevent continuous consumption of key battery power, after the vehicle is locked for 7 days, the function of unlock the doors when approaching/lock the door when leaving will be turned off, and the vehicle needs to be manually unlocked/locked.

### 4. Unlock/lock the door with button

Unlock: When doors are locked, press the unlock button 2 to unlock all doors.

Lock: When all doors are closed and in the unlocked state, press the unlock button 1 to lock all doors.



## 6. Operation

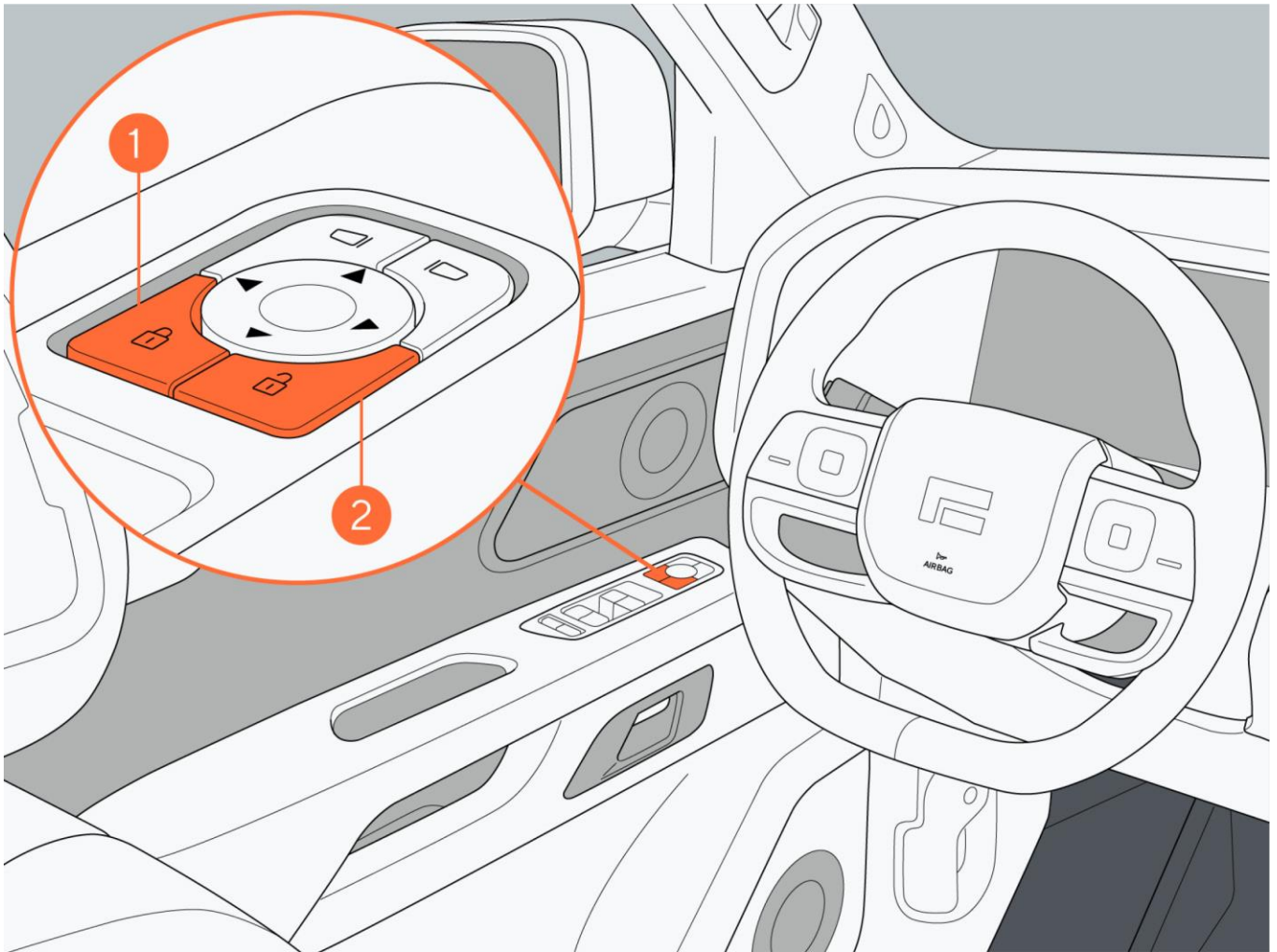

### 5. Unlock/ lock the door with central control screen

Unlock: When doors are locked, click the door lock icon on the control screen to unlock all doors.

Lock: When all doors are closed and in the unlocked state, click the door lock icon on the control screen to lock all doors.

### 6. Auto-unlock for parking

All doors will unlock when they are locked and the vehicle is shifted to P from other gears.

### 7. Auto re-locking

After unlocking the door from outside if no door or trunk door is opened within 30 s, the door will be automatically re-locked.

### 8. Auto-lock during driving

During driving, if the speed is greater than or equal to 15 km/h, all doors will be automatically locked.

### 9. Auto-unlock due to collision

The vehicle power is in "READY" or "ON" mode. When the vehicle suffered a serious collision, all doors will be automatically unlocked and the hazard warning light will be on.

### III. Emergency unlocking and locking door

When the door cannot be unlocked/locked with the remote key or keyless entry, the driver door can be unlocked/locked with the mechanical key.



1. Pull the door handle outward.

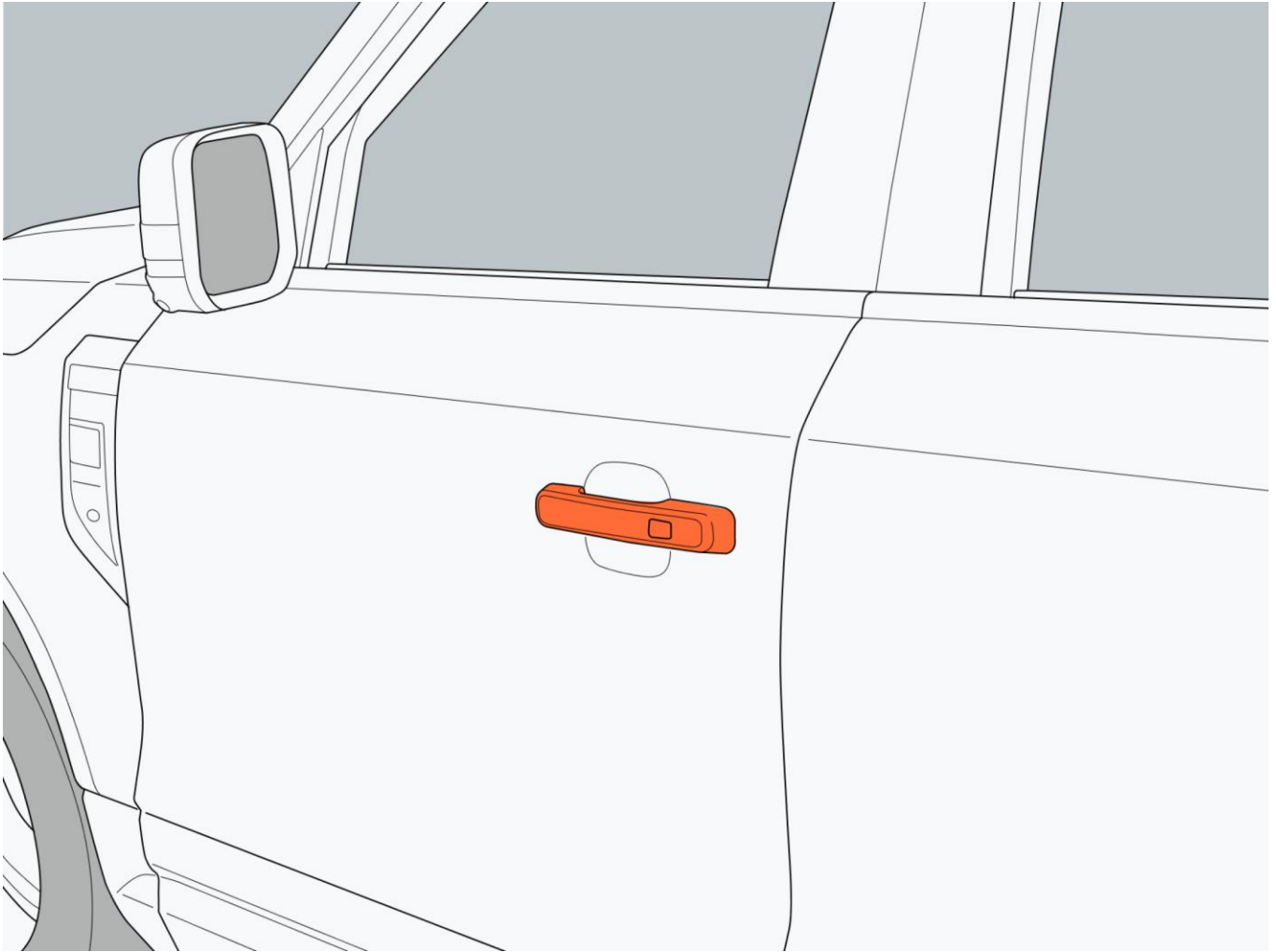

2. Insert a mechanical key into the keyhole and turn the key:

Unlock: Turn the key clockwise to unlock the driver door.

Lock: When all doors, hood and trunk doors are closed, turn the key lock counterclockwise to lock the driver door.

## 6. Operation

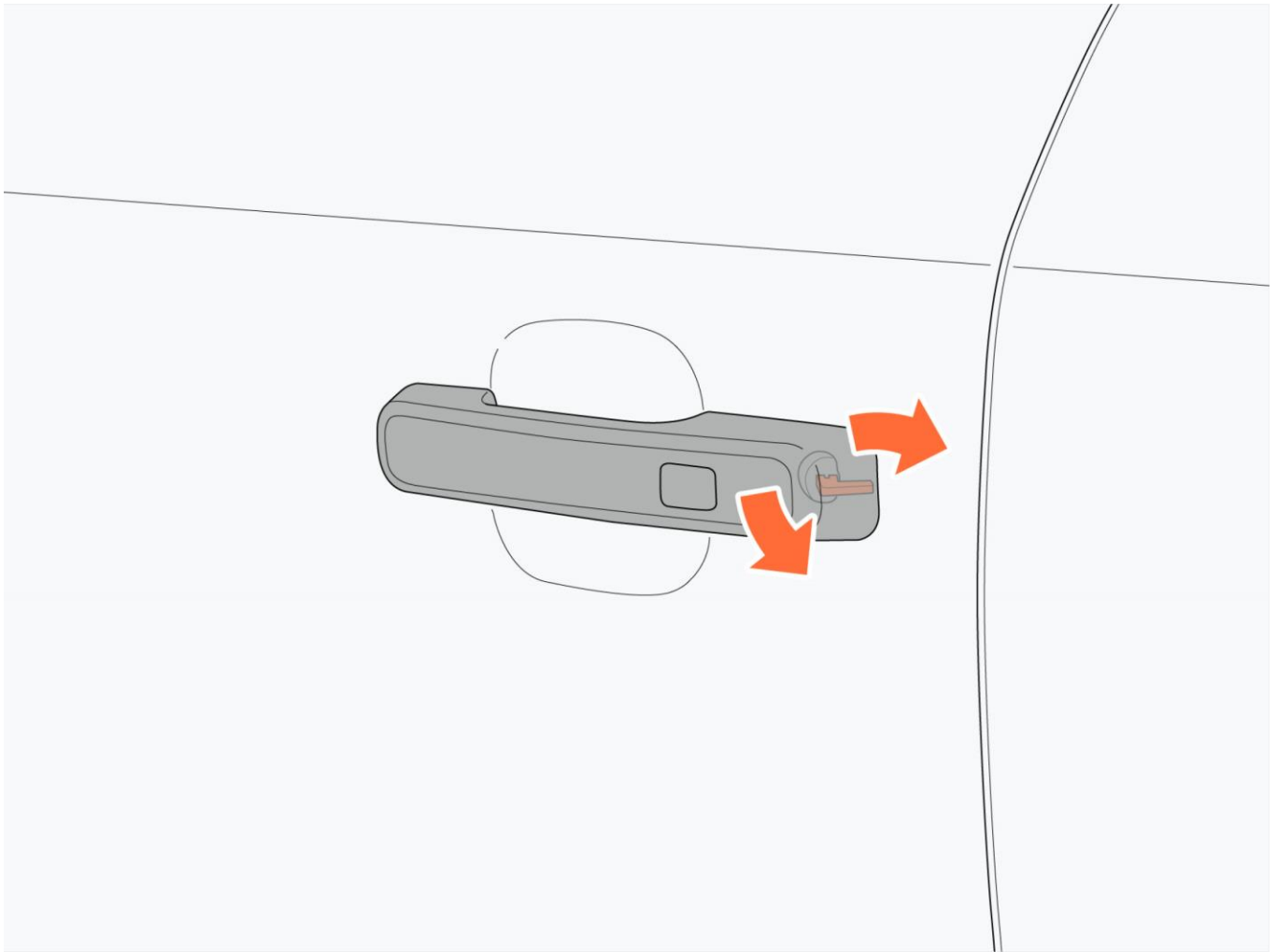

### IV. Door lock settings

#### 1. Honk on lock

Click " Vehicle Settings → Vehicle → Door Lock → Lock Whistle" through the central control screen, to set the activation and deactivation of the lock whistle prompt sound.

#### 2. Key unlock method

Click "Vehicle Settings → Vehicle → Door Lock → Key Unlock" through the central control screen, to set the key unlock method:

Unlock the driver door: When using the remote key to unlock the car, only the driver door can be unlocked.

Unlock the car: Unlock all doors with the remote key.

#### 3. Auto-unlock for parking

Click " Vehicle Settings → Vehicle → Door Lock → Auto-unlock for Parking" through the central control screen, to set the activation and deactivation of the auto-unlock for parking.

#### 4. Unlock the door when approaching/lock the door when leaving

Click "Vehicle Settings → Vehicle → Door Lock → Auto-Lock When Leaving" through the central control screen, to set the activation and deactivation of unlocking when approaching/locking when leaving.

### Warning

- After activation of the unlocking when approaching/lock when leaving function, ensure that there

are no children or pets in the car before leaving the car to avoid accidents.

- Do not open the door during driving to avoid accidents.
- When closing the door, do not put your hands on the edge of the door. Ensure that there are no other obstacles on the edge of the door to avoid being pinched or damaging the door.
- Before opening the door, be sure to check whether there are other pedestrians or vehicles on the door-side road.
- Do not leave children or pets in the car alone. Sealed vehicles can get hot. Children or animals can be seriously injured or even killed because they can't escape the vehicle. Children may be harmed by operating vehicle equipment. Children may also suffer other injuries due to intruders entering the car.

### 6.2.2 Trunk door

#### I. Unlock the trunk door

##### 1. Trunk door open switch button

Applicable to models without spare tires: Press the trunk door open switch button with carrying the remote key or Bluetooth key to unlock the trunk door.

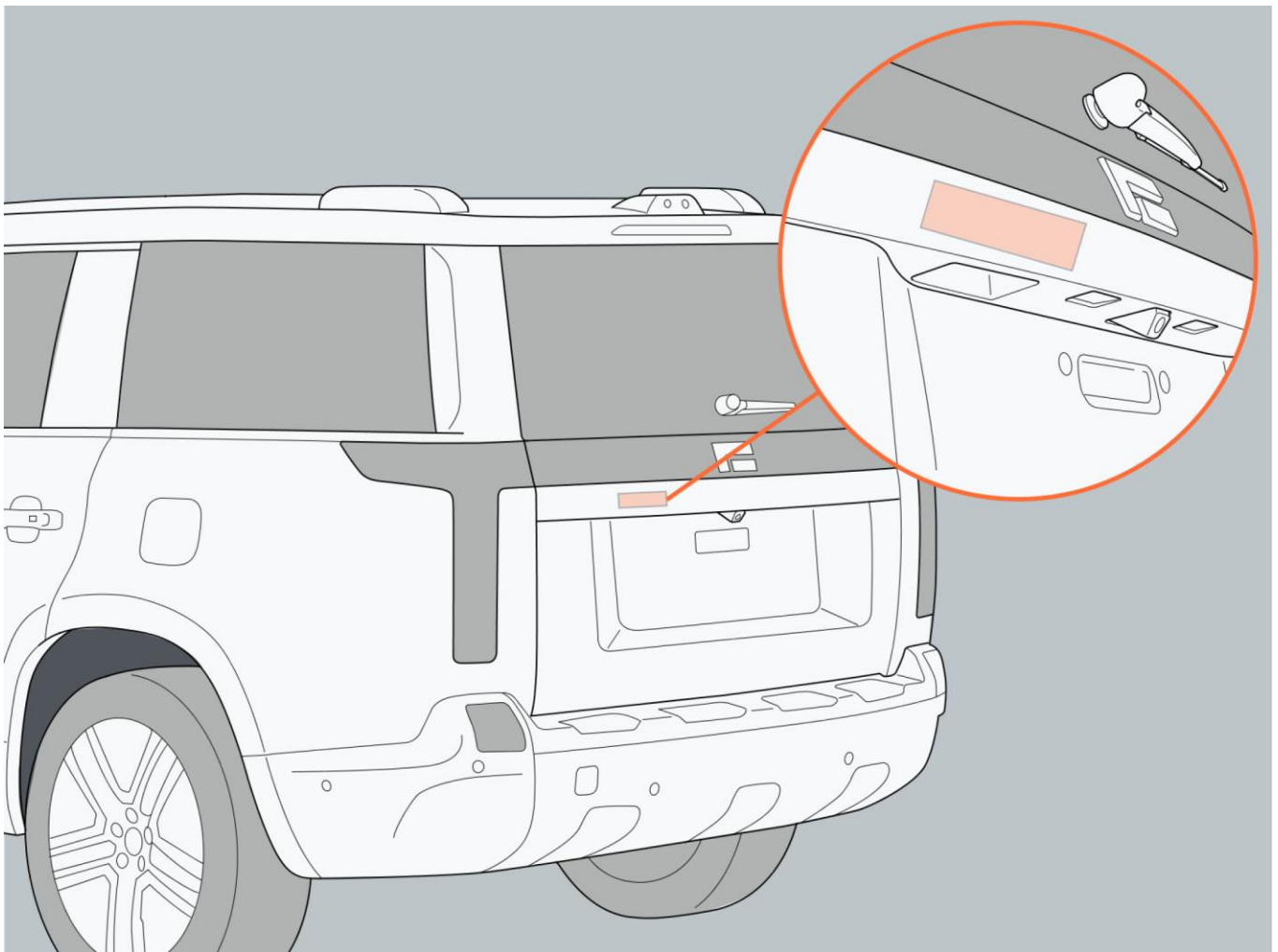

## 6. Operation

Applicable to models with spare tire: Pull the trunk door to open the switch handle with carrying the remote key or Bluetooth key to unlock the trunk door.

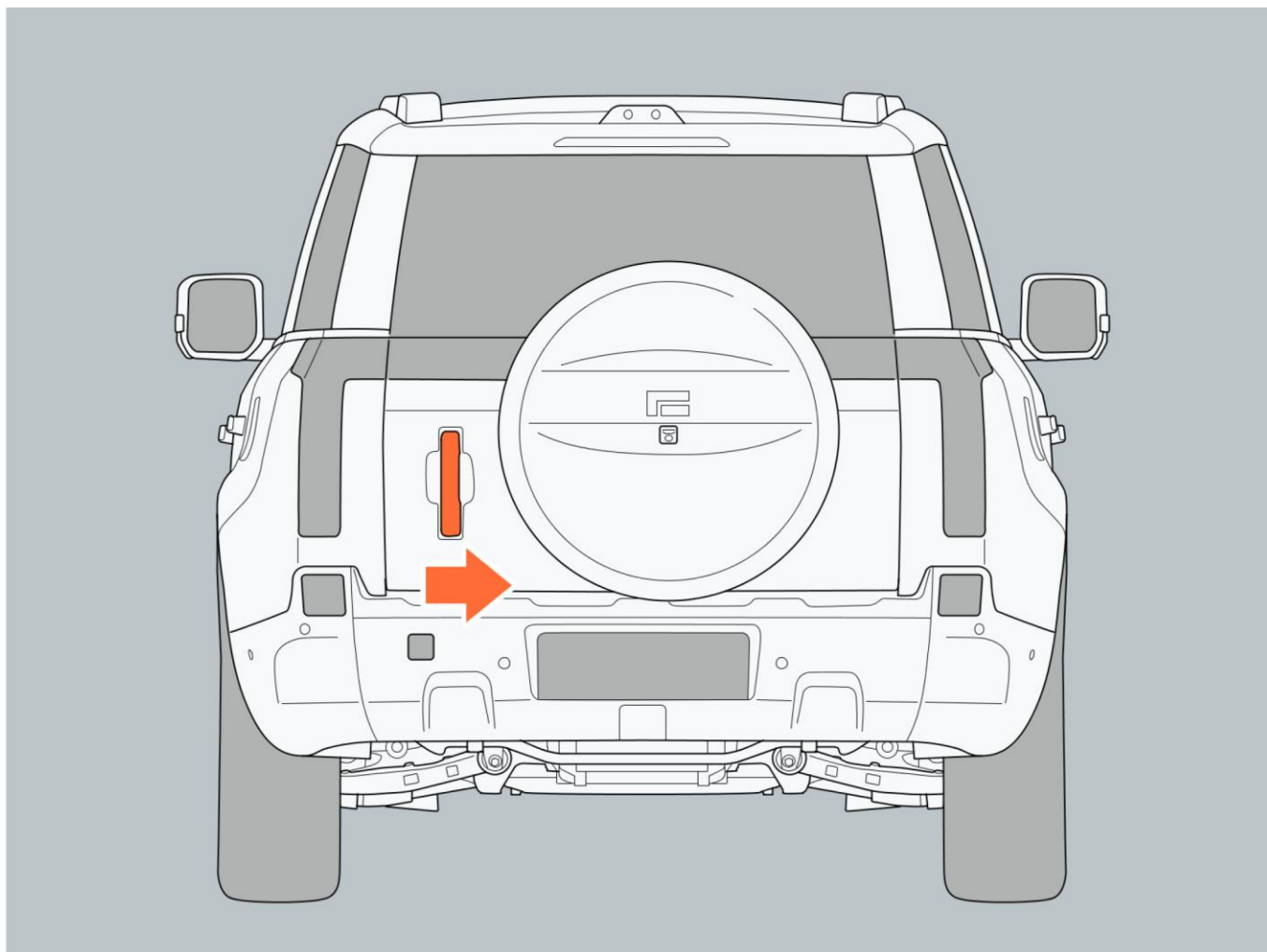

### 2. Remote key unlocking

Press the remote key unlock button within the effective mileage to unlock the trunk door.

### II. Open the trunk door

Applicable to models without spare tires: When the trunk door is in an unlocked state, press the trunk door open button to open the trunk door.

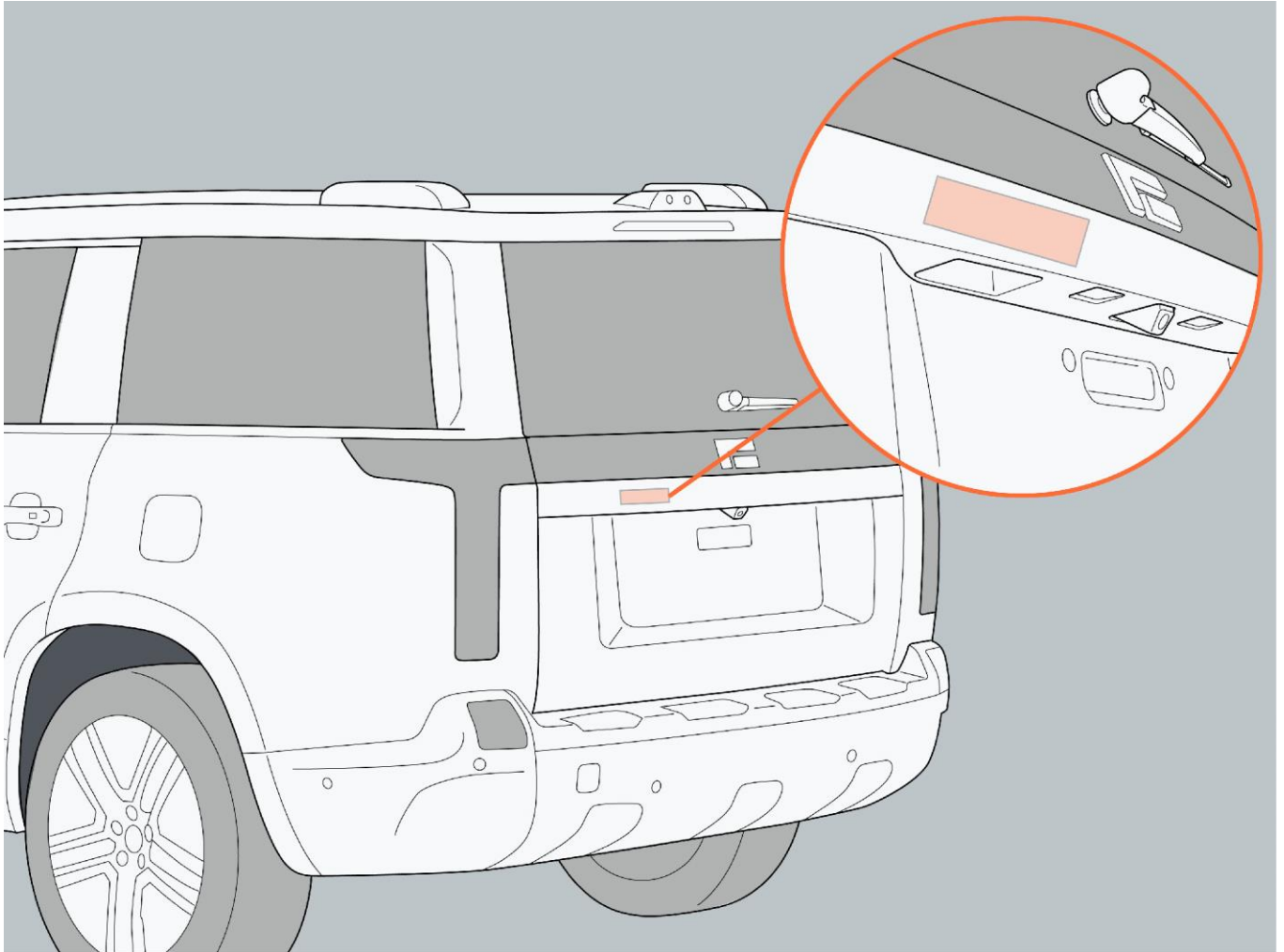

## 6. Operation

Applicable to models with spare tire: When the trunk door is in an unlocked state, pull the trunk door to open the switch handle to open the trunk door.

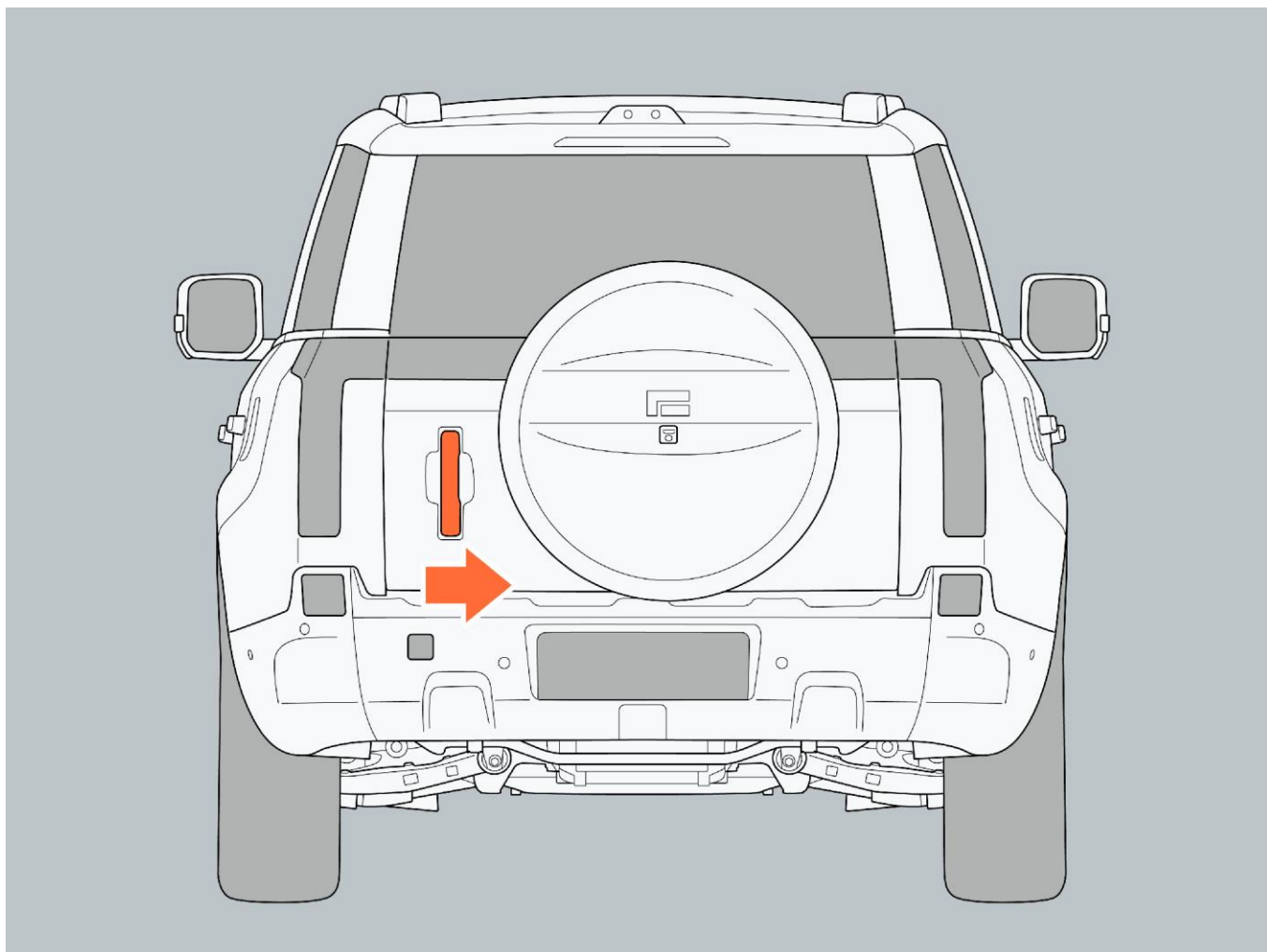

### III. Keep the trunk door open

1. Unlock the trunk door opening limiter.
2. Lock the trunk door opening limiter.

The trunk door opening limiter can be operated only when the trunk door is fully opened.

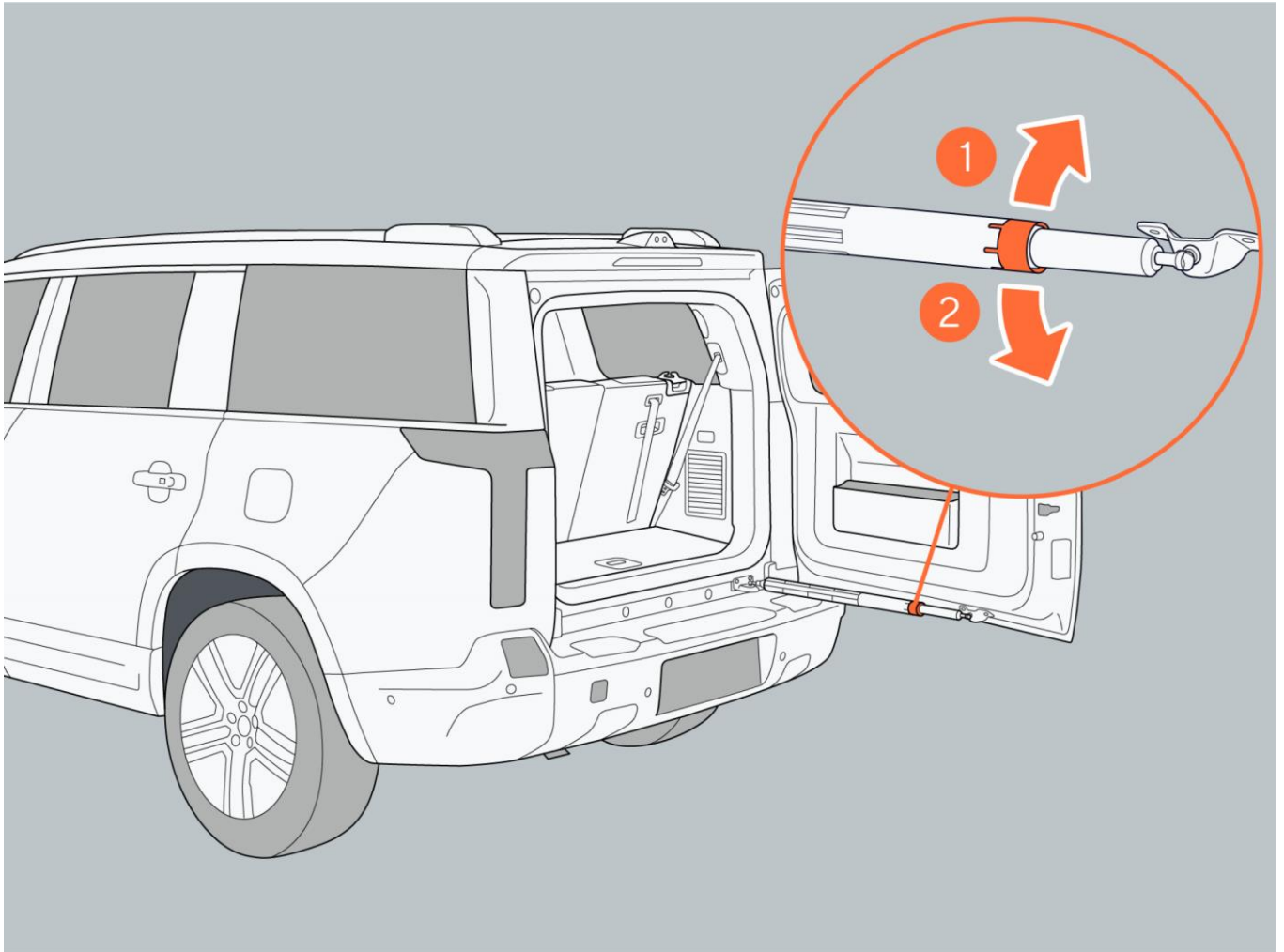

## 6. Operation

### IV. Close the trunk door

Close the trunk door inward directly until it is closed in place.

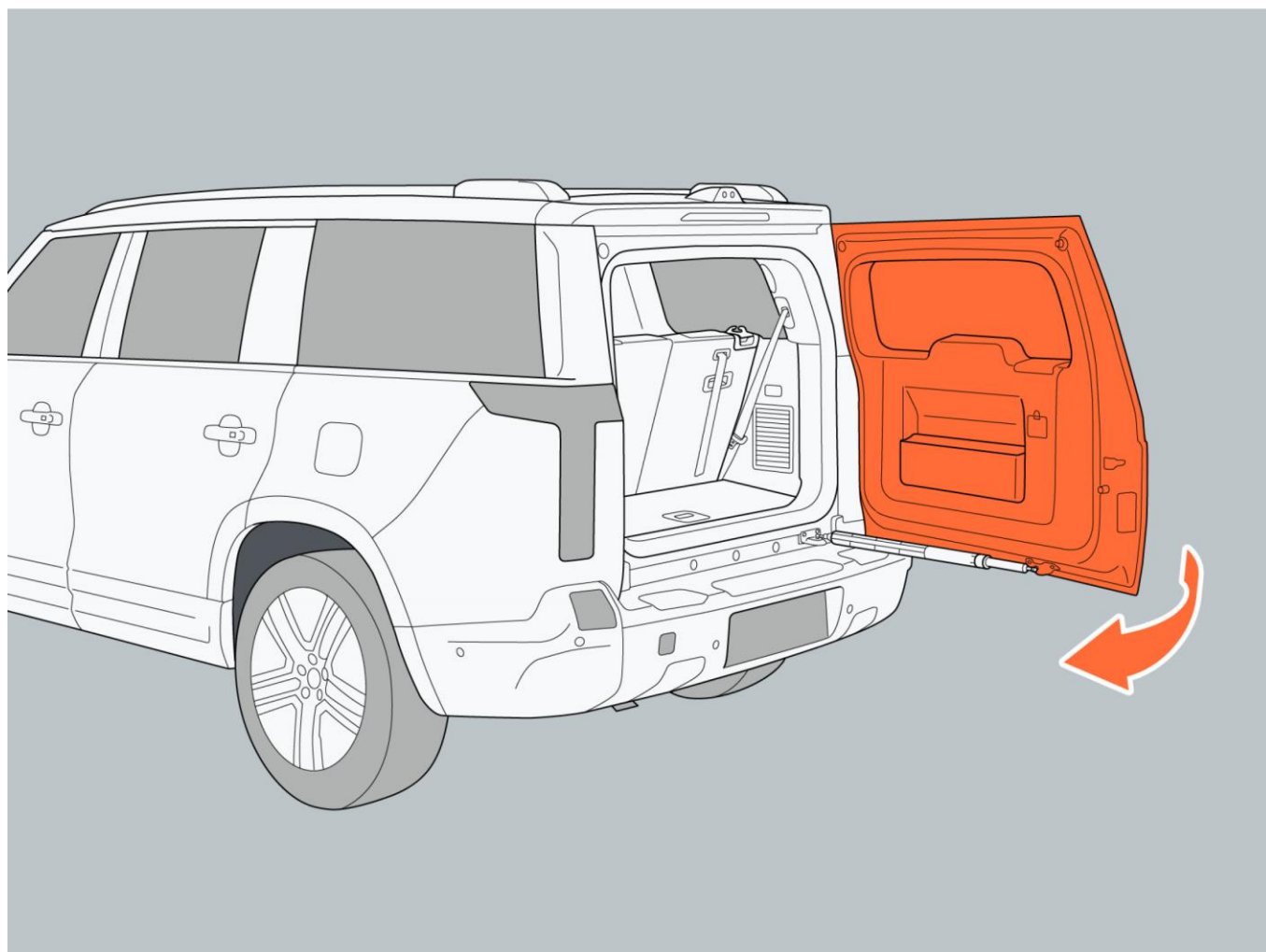



V. Open the trunk door in emergency

1. Enter the trunk.
2. Press the clip on the door lock trim cover to remove the door lock trim cover outward.

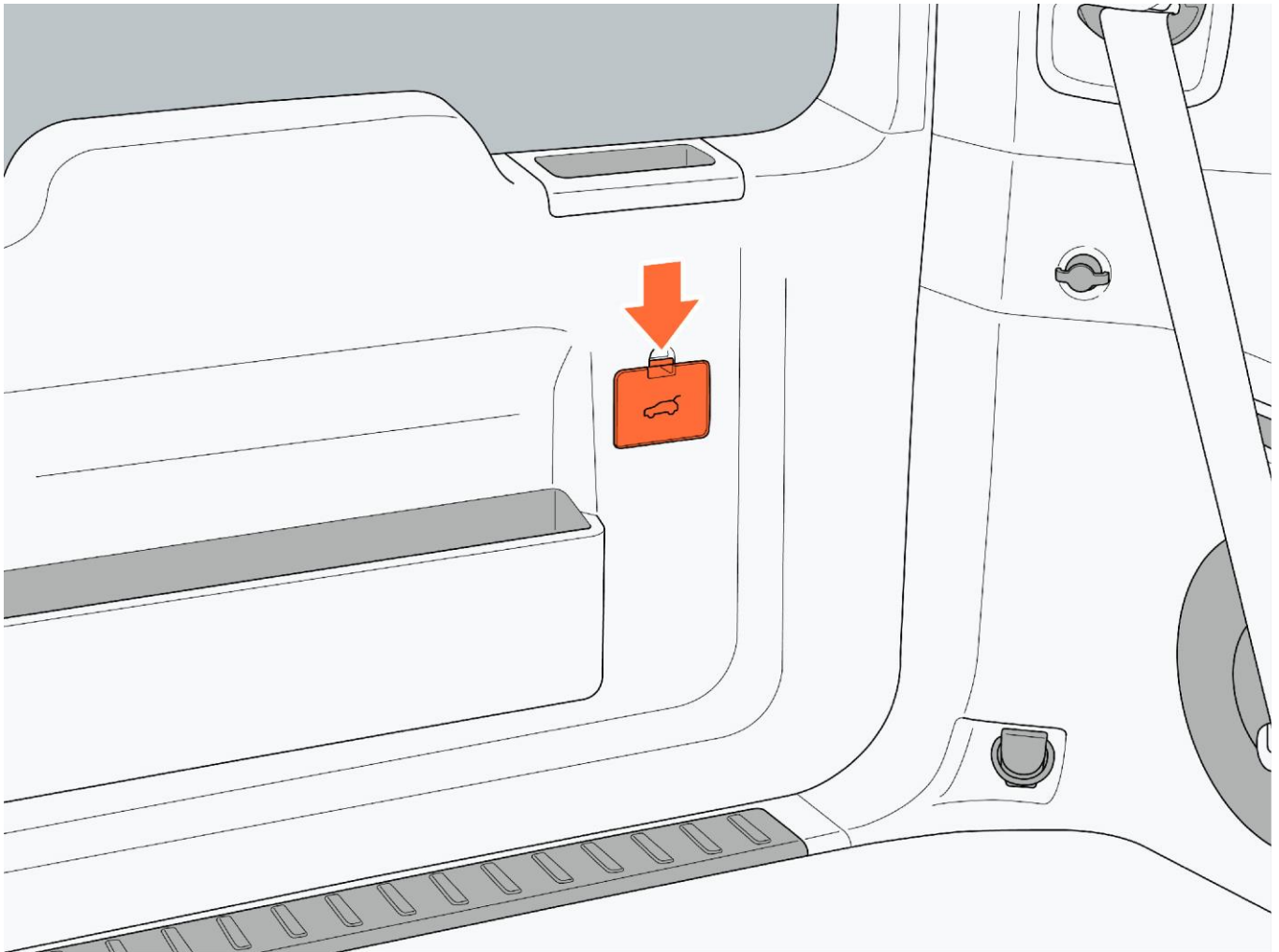

## 6. Operation

3. Pull the unlocking cable upwards and push the trunk door outward at the same time to unlock and open the trunk door.

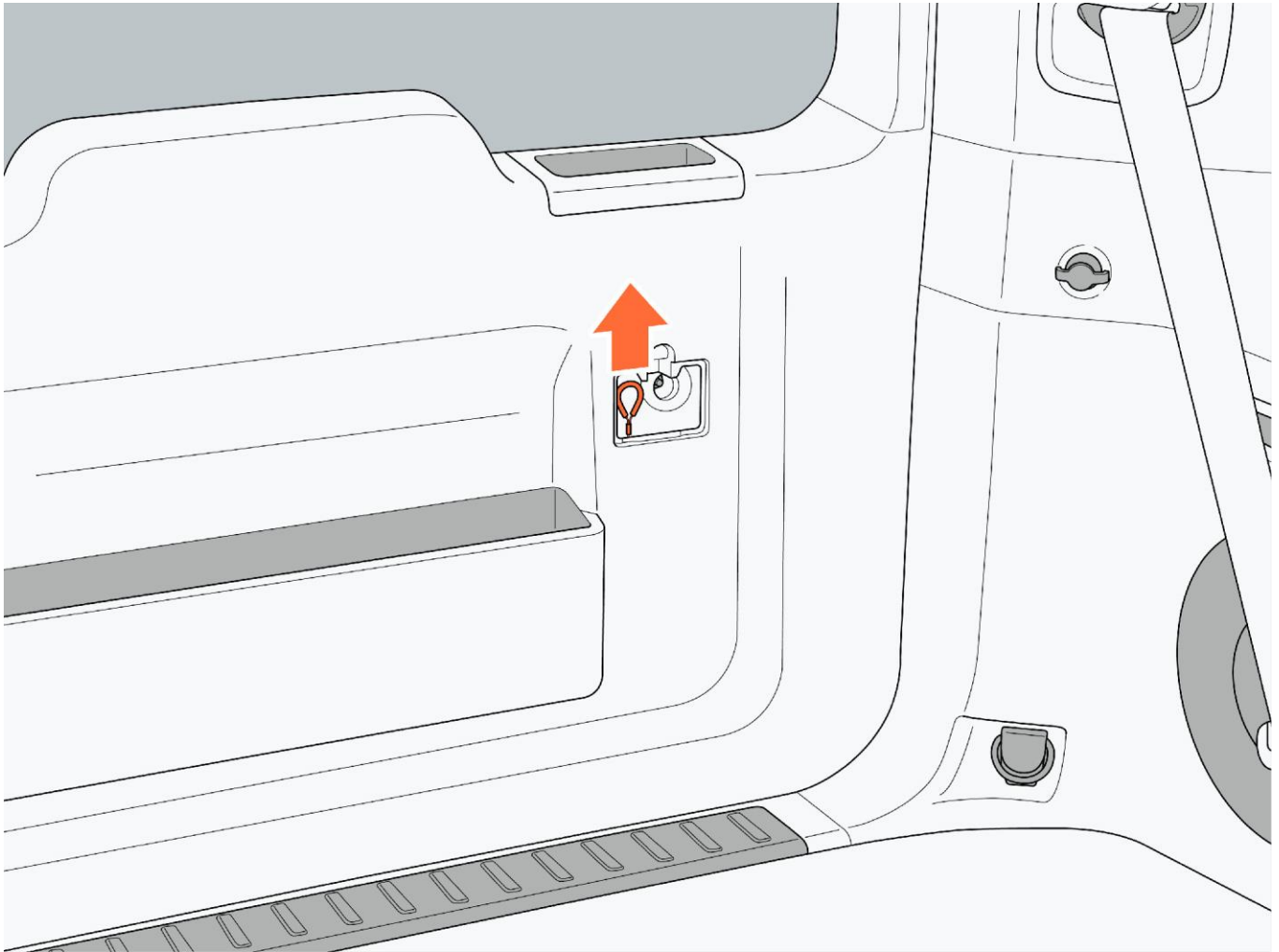

### VI. Electric suction function

If the trunk door is closed from the fully open state to the half-locked state, the trunk door will automatically suck until it is completely closed.

#### Warning

- The electric suction function does not have an anti-pinch function. Be sure to close the trunk door safely without clipping any objects, including fingers, to avoid pinch injuries or property damage.
- When opening or closing the trunk door, make sure that the surrounding area is safe.
- Do not allow children to operate the trunk door or play near the open trunk door. Unintended closure due to an improperly secured trunk door may result in pinching and injury to their body parts.
- Do not drive the vehicle when the trunk door is not locked normally, to avoid the sudden opening of the trunk door, causing items to fall or accidents. In addition, abnormal locking of the trunk door may cause exhaust gas to enter the car, endangering health and causing death in severe cases.
- Do not sit in the trunk during driving. In the event of emergency braking or a collision, there is a high risk of safety accidents that could lead to injury.

- Be careful when opening the trunk door in strong wind conditions. Under the action of strong wind, the trunk door may be deformed due to too large opening.

### **i** Tip

- The vehicle is automatically locked only when the trunk door is in the unlocked state, and the trunk door is still closed after 30 s.

## 6.3 Seat adjustment

### 6.3.1 Front row seats

#### I. Seat adjustment

##### 1. Adjust the seat position

- Adjust the front and rear positions of the seat: Push the seat buttons back and forth. Pull the front of the adjustment button up and down to adjust the inclination of the seat cushion. Pull the rear of the adjustment button up and down to adjust the seat height.
- Adjust the seat leg support: Press the front button to extend the leg support. Press the rear button to retract the leg support.
- Adjust the seat backrest angle: Turn the backrest button back and forth.

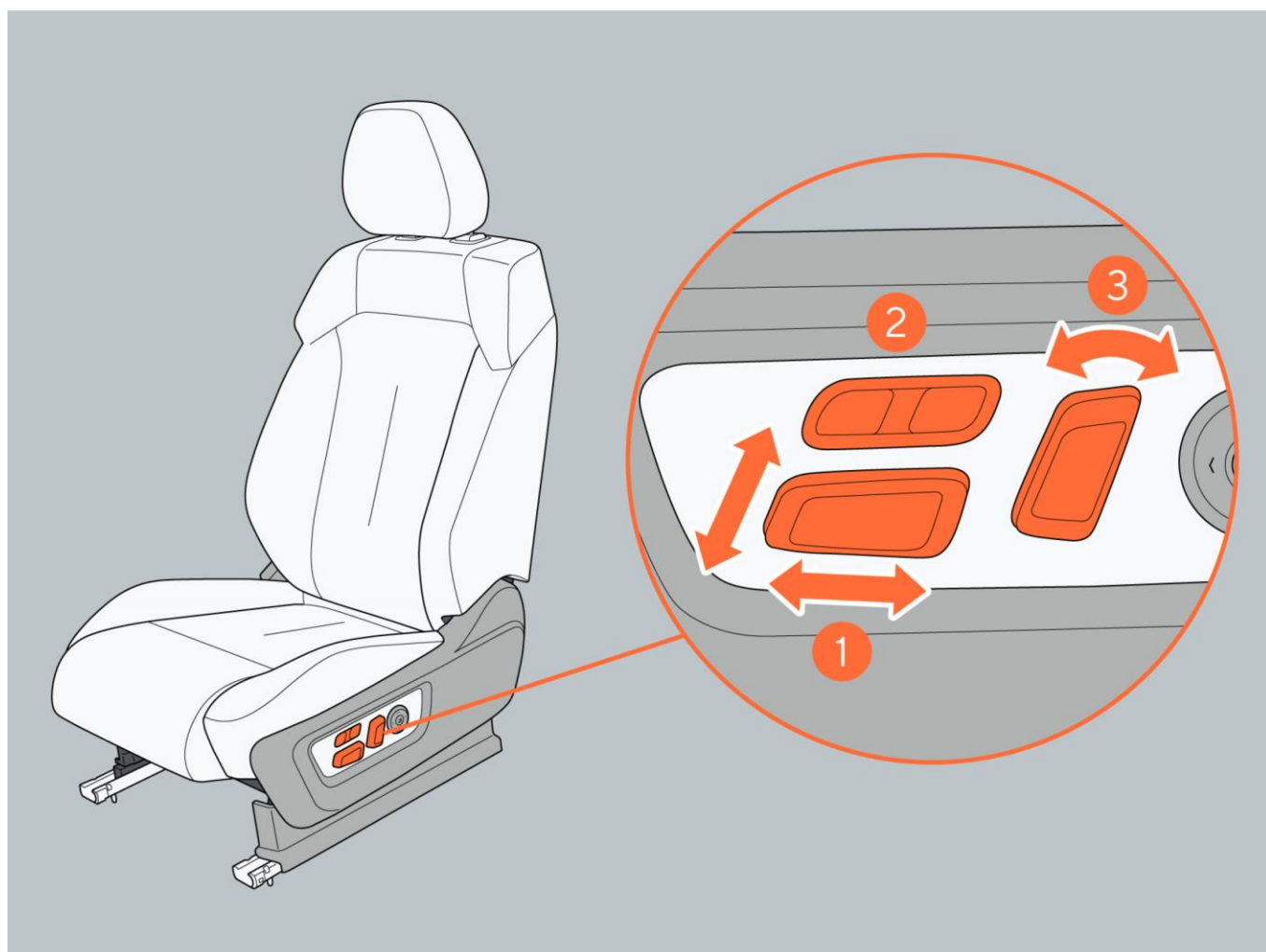

## 6. Operation

### 2. Adjust the seat waist support

- Enhance waist supporting: Press the front part of the waist support button.
- Move down: Press the lower part of the waist support button.
- Weaken waist supporting: Press the back of the waist support button.
- Move up: Press the upper part of the waist support button.

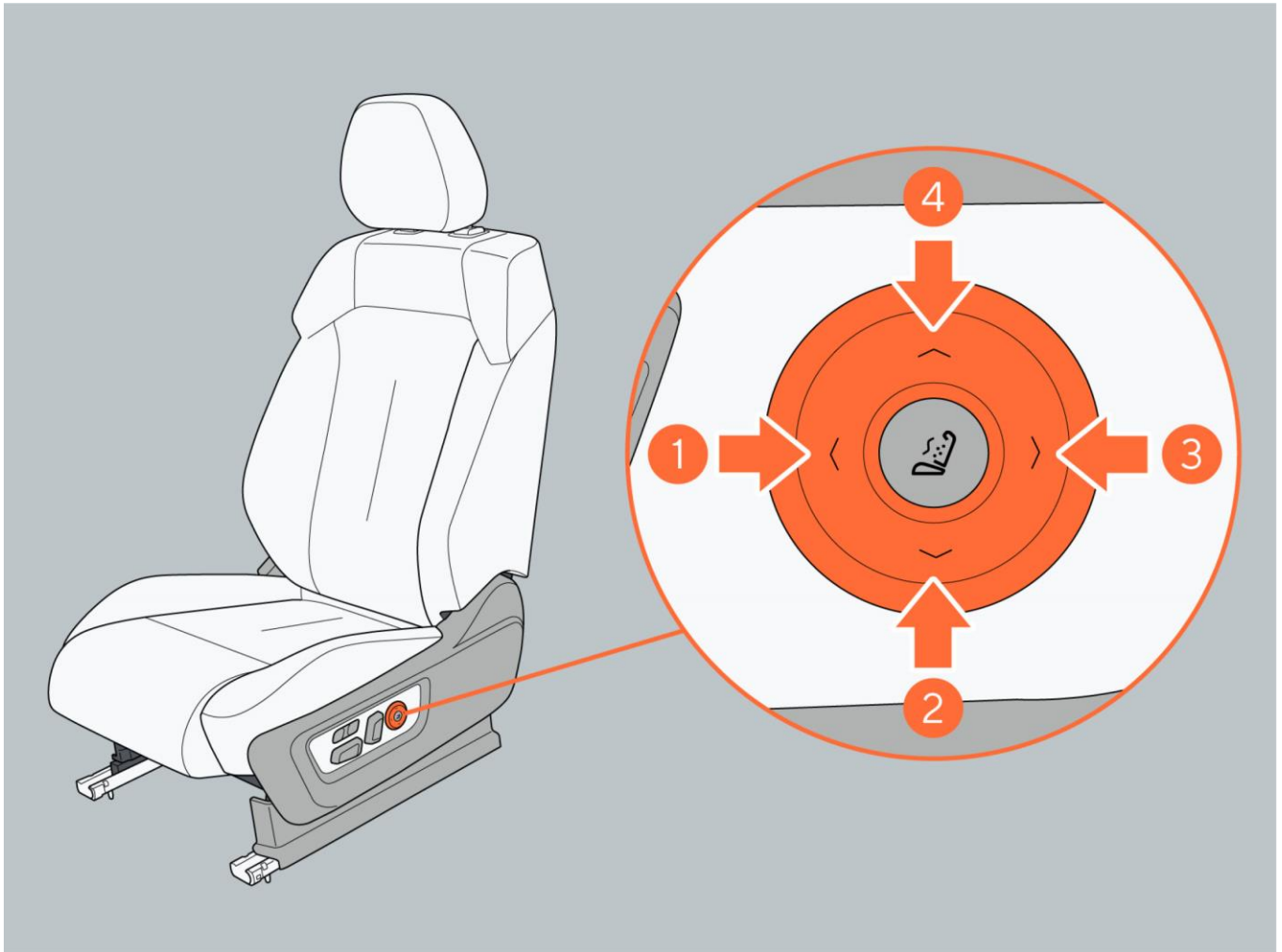

### II. Front-row seat massage

#### 1. Activate/deactivate through the central control screen

When the vehicle is in the "READY" mode, click the "Seat" icon on the A/C system control interface of the central control screen to enter the seat massage control interface; Activation: Click the "Start Massage" icon to activate the seat massage function.

Deactivation: Click the "Turn off Massage" icon to deactivate the seat massage function.

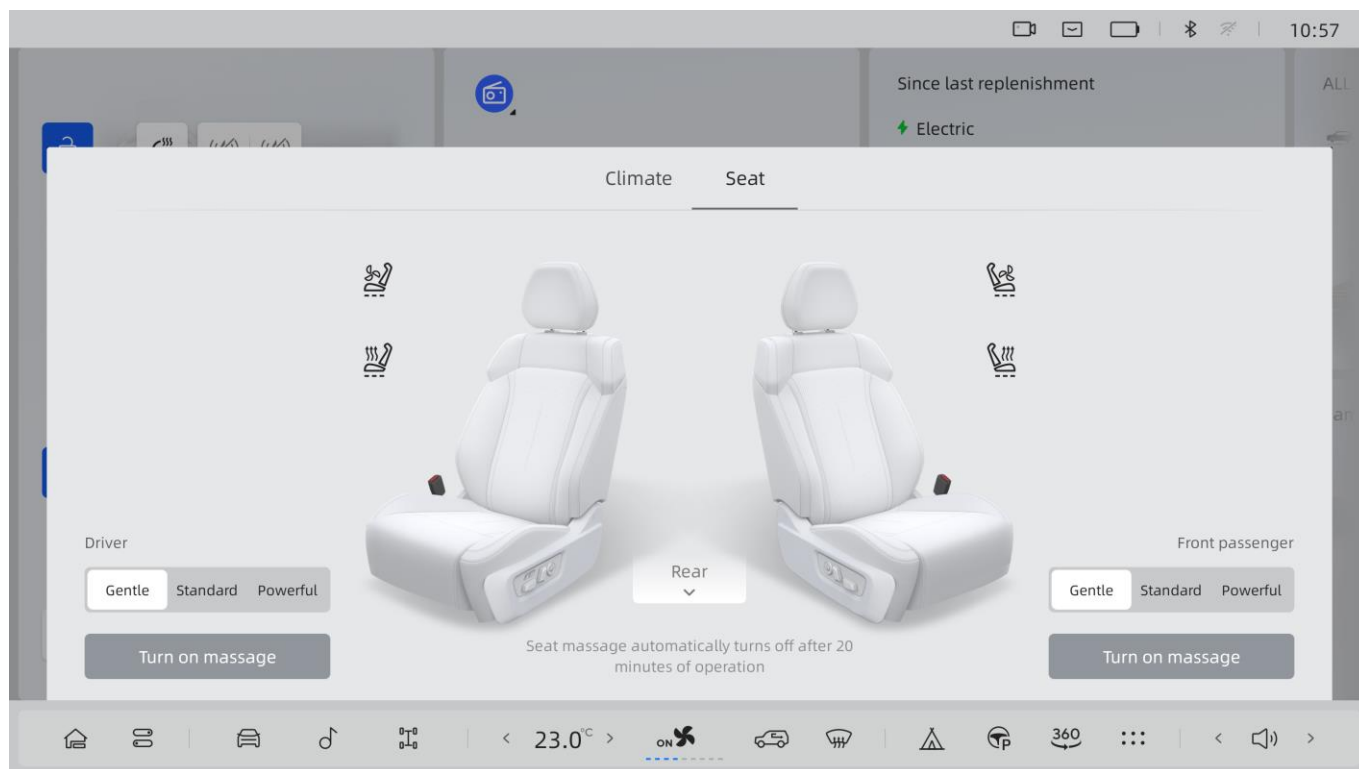

## 2. Activate and deactivate seat massage with a button

Activation: When the massage function is off, short press the massage button to activate the massage function.

Deactivation: When the massage function is on, short press the massage button to deactivate the massage function.

After the massage function is activated, short press the seat massage button again to switch the seat massage intensity. The start intensity is strong mode by default, and the switching order is strong, standard, gentle and off.

When the massage function is on, operate the waist support adjustment button to deactivate the massage function.

## 6. Operation

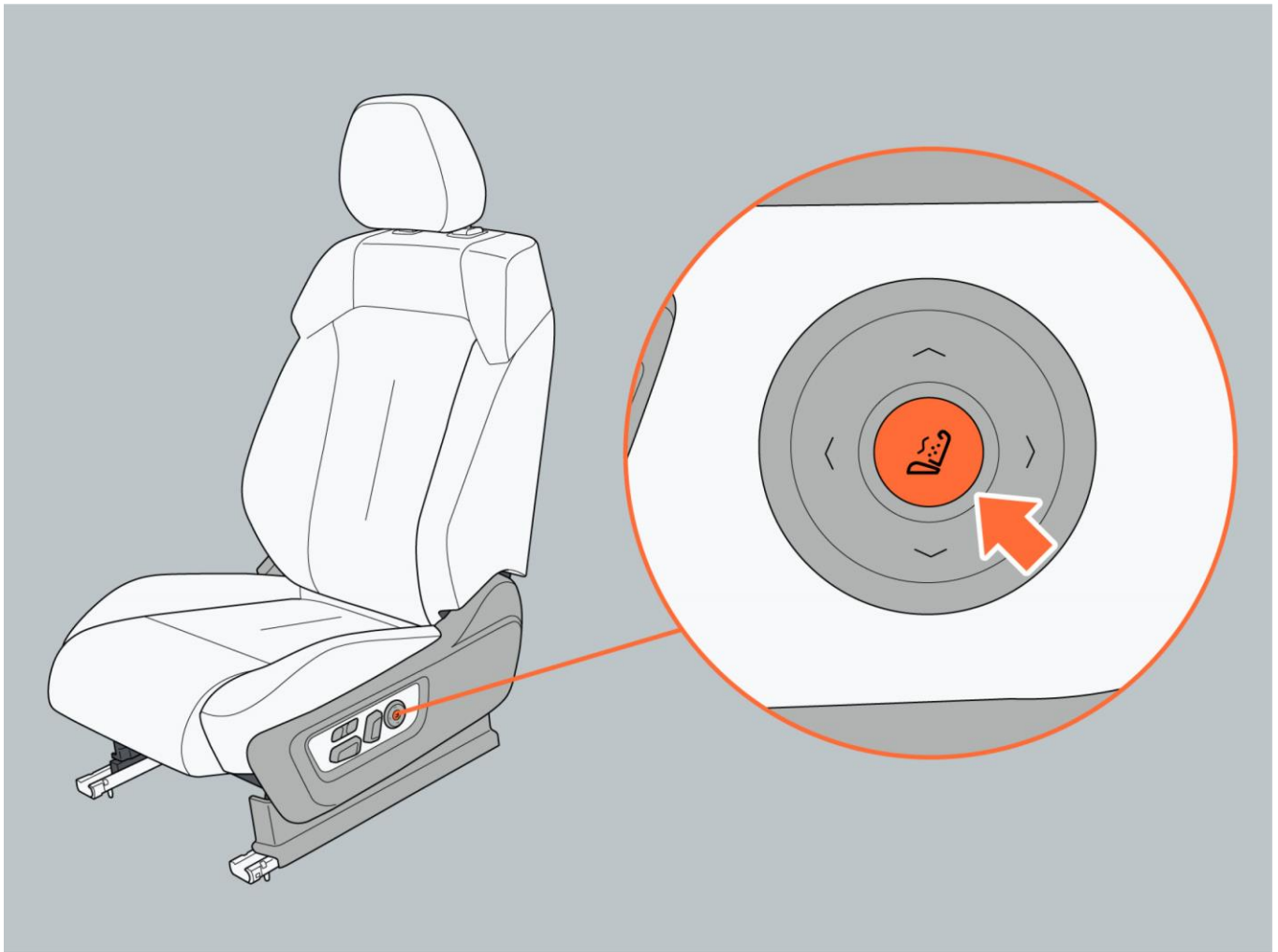

### III. Seat position parameter

Seat travel: 200 mm forward, 60 mm backward.

Up and down travel: 20 mm down, 40 mm up.

#### Warning

- Do not adjust the driver's seat while driving to avoid losing control of the vehicle due to sudden body tilt.
- Do not tilt the seat backrest too backward. Otherwise it will seriously affect the protection of seat belts and airbags.
- Do not drive the vehicle when the seat and the headrest are not adjusted correctly or the seat belt is not fastened, to prevent it from being unable to provide protection in the event of an accident.
- When adjusting the seat, do not place your hands on the seat movement area to avoid pinching.

### 6.3.2 Second row seats

#### I. Seat adjustment (common seat)

##### 1. Adjust the seat position

- Adjust the front and rear positions of the seat: Push the seat button back and forth.

- Adjust the seat backrest angle: Turn the backrest button back and forth.
- Adjust the seat armrest: Push the seat armrest up and down. Lift the armrest up to the highest position and then put it down. The armrest can be reset to the lowest position.

### ⚠ Caution

- When seat armrest is lowered, do not place your hands on the armrest movement area to avoid pinching.

### i Tip

- When the seat backrest is tilted too forward, the seat armrest cannot be locked.

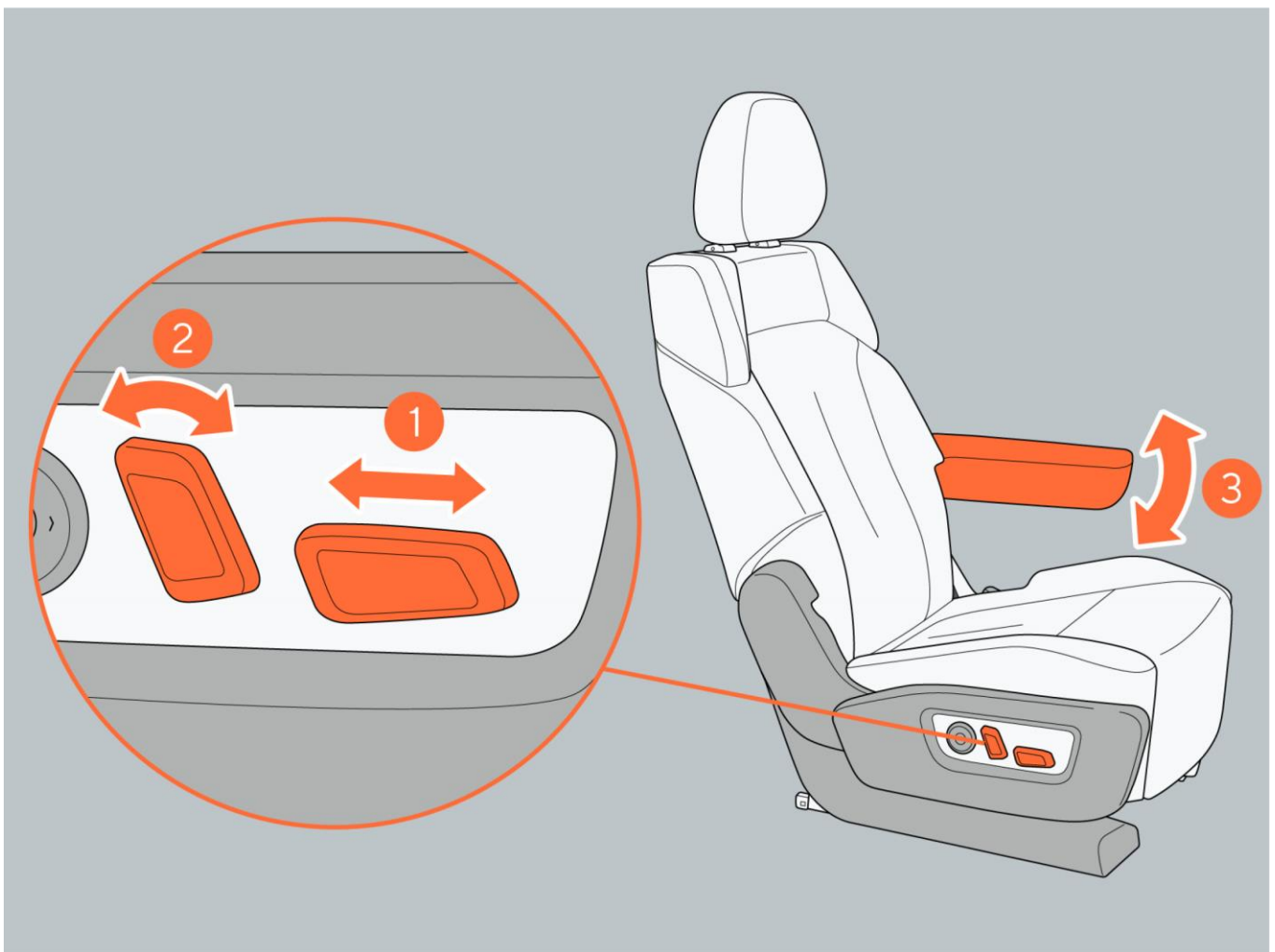

2. Adjust the seat position through the central control screen (common seat)

Click " Vehicle Settings → Vehicle → Seat" through the central control screen. Select the second-row left/right seat to adjust the front/rear movement of the seat and the angle of the backrest.

3. Adjust the seat waist support (common seat)

- Enhance waist supporting: Press the front part of the waist support button.
- Move down: Press the lower part of the waist support button.



## 6. Operation

- Weaken waist supporting: Press the back of the waist support button.
- Move up: Press the upper part of the waist support button.

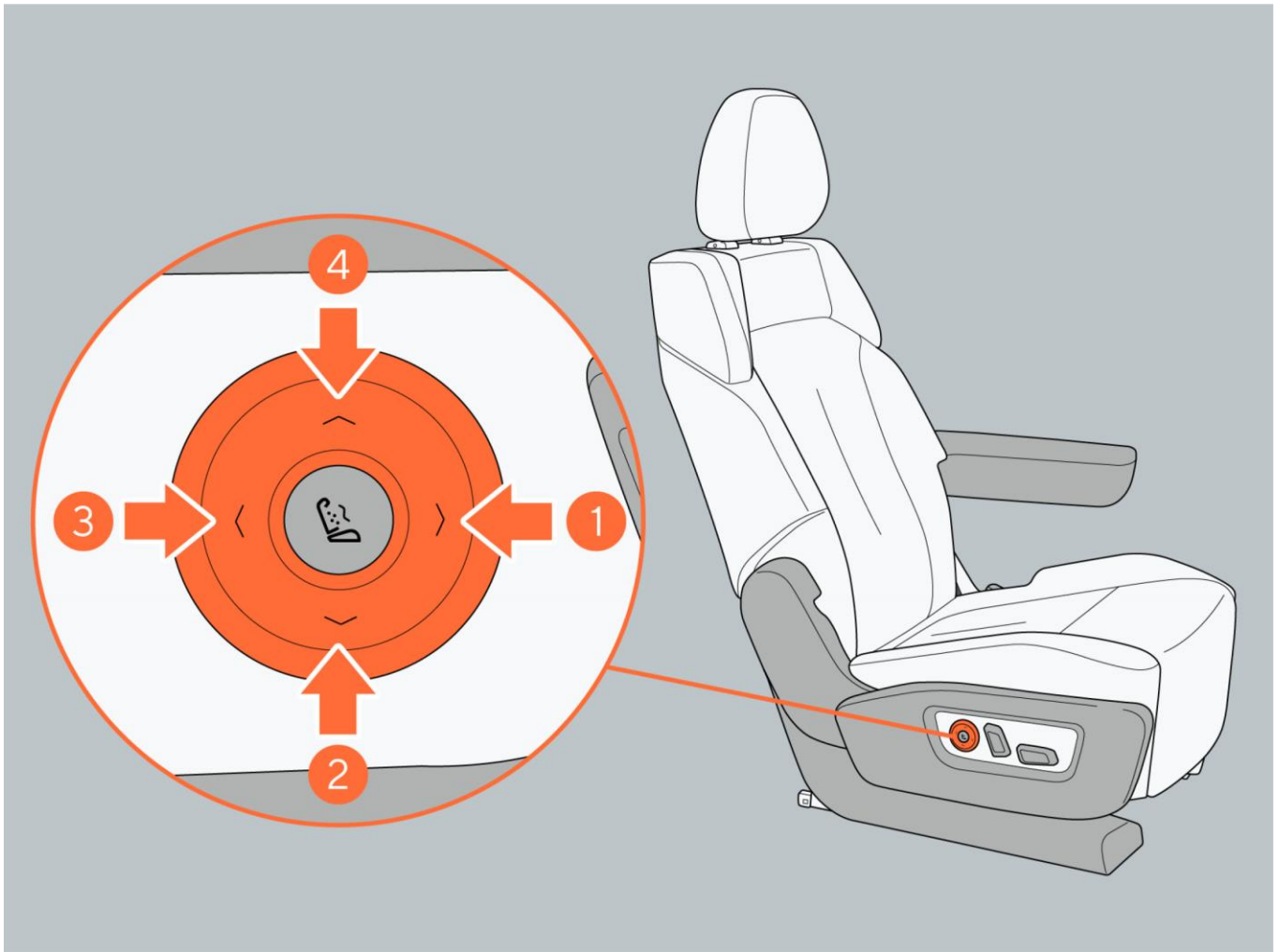

### 4. Activate and deactivate seat massage with a button (common seat)

Activation: When the massage function is off, short press the massage button to activate the massage function.

Deactivation: When the massage function is on, short press the massage button to deactivate the massage function.

After the massage function is activated, short press the seat massage button again to switch the seat massage intensity. The start intensity is strong mode by default, and the switching order is strong, standard, gentle and off.

When the massage function is on, operate the waist support adjustment button to deactivate the massage function.



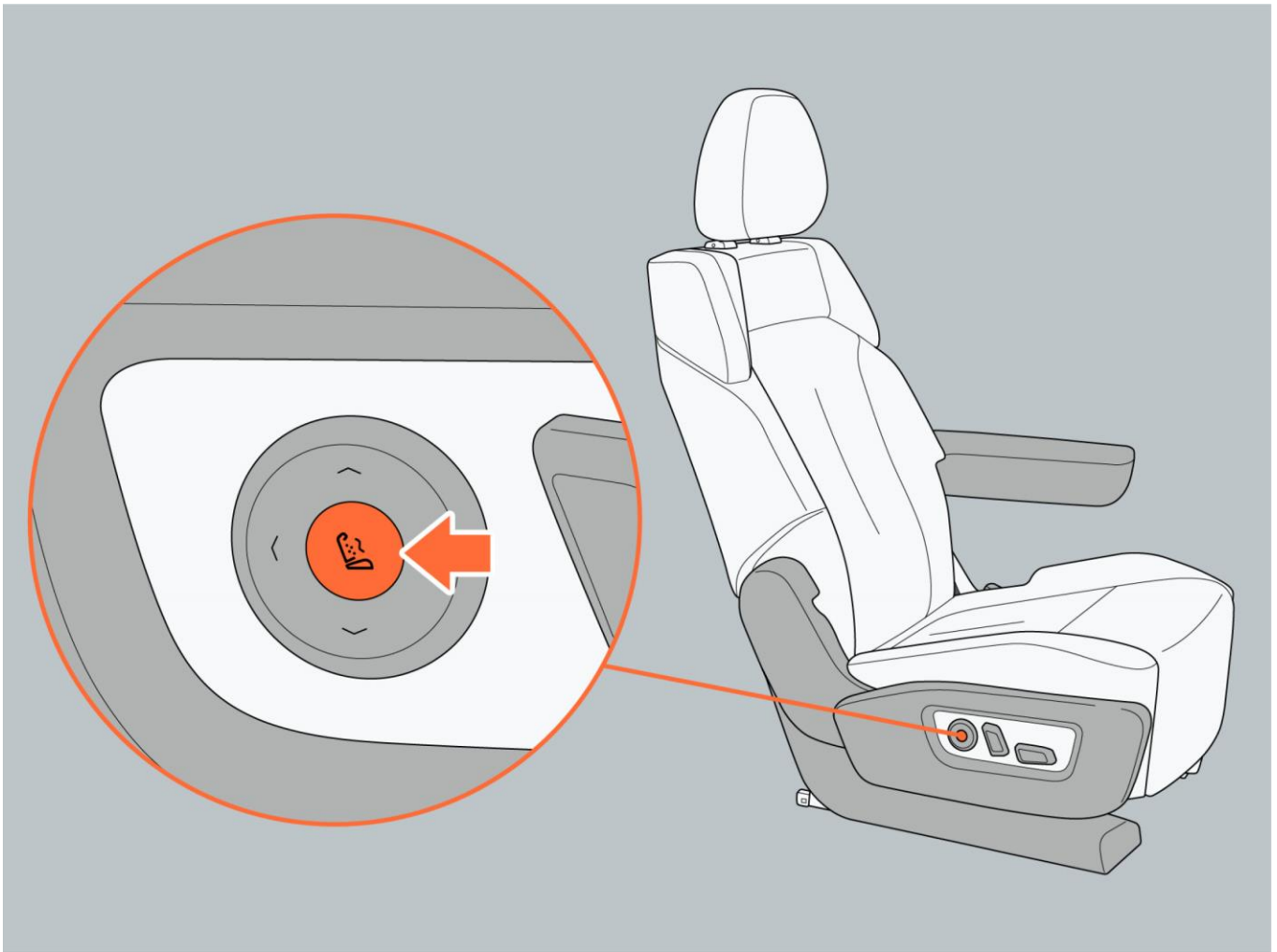

5. Activate and deactivate seat massage through the central control screen (common seat)

Click " A/C Control Interface → Seat" through the central control screen, and select the second-row left/right seat massage function. Activation: When the massage function is off, click Start Massage to activate the massage function.

Deactivation: When the massage function is on, click Close Massage to deactivate the massage function.

Massage intensity: There are three intensity options for seat massage intensity: strong, standard and gentle.

II. Seat adjustment (aviation seat)

1. Adjust the seat position with button

The seat control button is located under the armrest cover of the seat. Open the armrest cover and you may see:

- Adjust the seat leg support position: Press button 1 or button 2 to control the leg support to move up or down.
- Adjust the front and rear position of the seat: Press button 3 or button 4 to control the seat to move forward or backward.
- Adjust the angle of the seat cushion: Press button 5 or button 6 to control the seat cushion to tilt forward or backward.

## 6. Operation

- Adjust the angle of the seat backrest: Press button 7 or button 8 to control the backrest to move forward or backward.

The outer armrest of the aviation seat can slide forward and backward. Slide the outer armrest forward when riding, and retreat the armrest when getting off the car, to facilitate occupants to get on and off the vehicle.

### ⚠ Caution

- When the armrest slides out, occupants may misuse the armrest when getting on and off, resulting in unsafely risks and damage to parts.
- Do not stand or sit on the seat leg support when using the seat leg support. Standing on the leg support may cause damage to the leg support, or cause serious personal injury due to a fall. When sitting on the leg support, you cannot wear the seat belt correctly, and may be thrown out of the seat in the event of an accident or emergency braking, resulting in serious casualties.

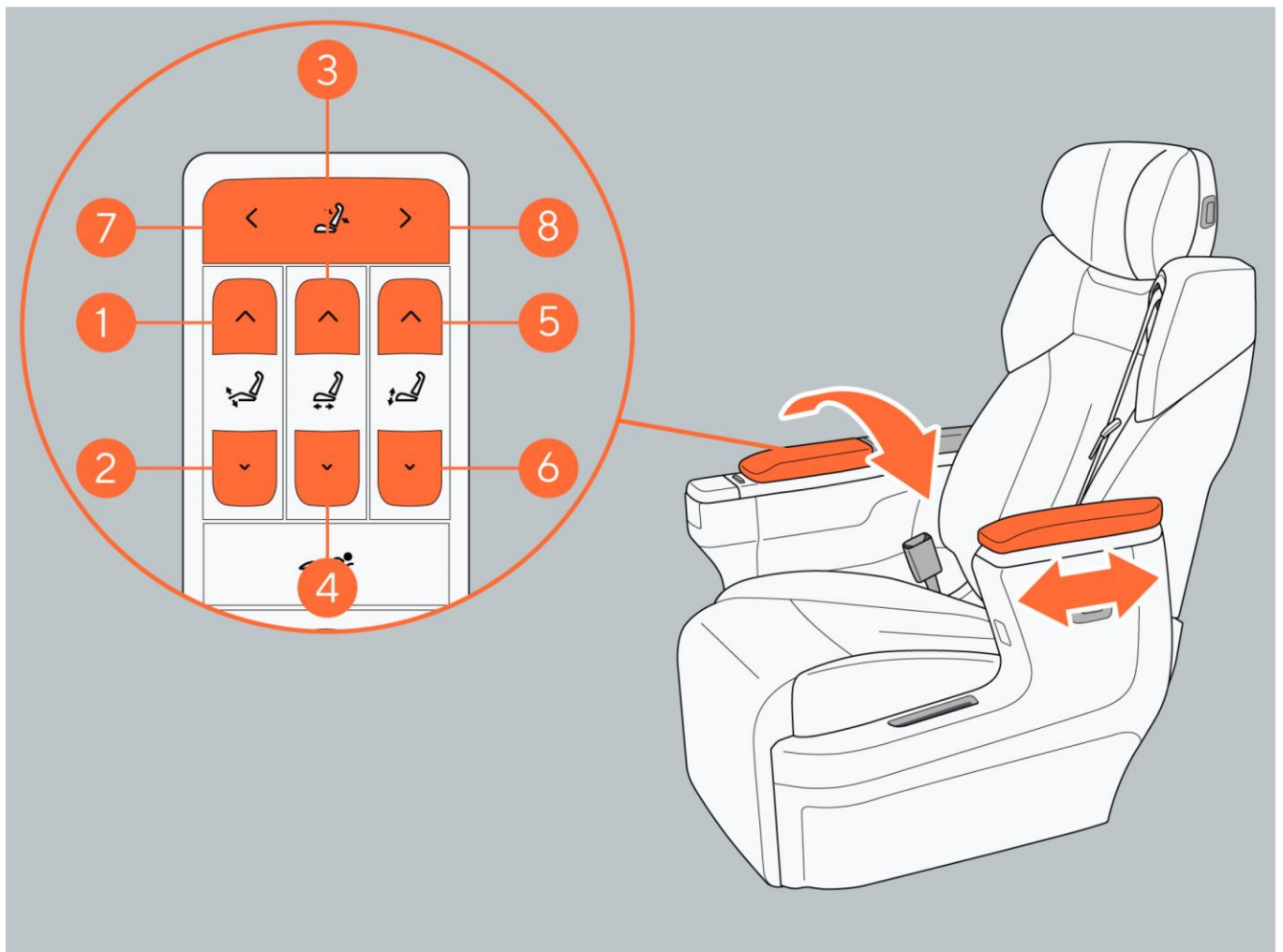

2. Adjust the seat position through the central control screen (aviation seat)

Click " Vehicle Settings → Vehicle → Seat" through the central control screen. Select the second-row left/right seat to adjust the front/rear movement of the seat, the angle of the backrest and the leg support.

3. Adjust the seat waist support (aviation seat)

- Enhance waist supporting: Press the front part of the waist support button.
- Move down: Press the lower part of the waist support button.
- Weaken waist supporting: Press the back of the waist support button.
- Move up: Press the upper part of the waist support button.

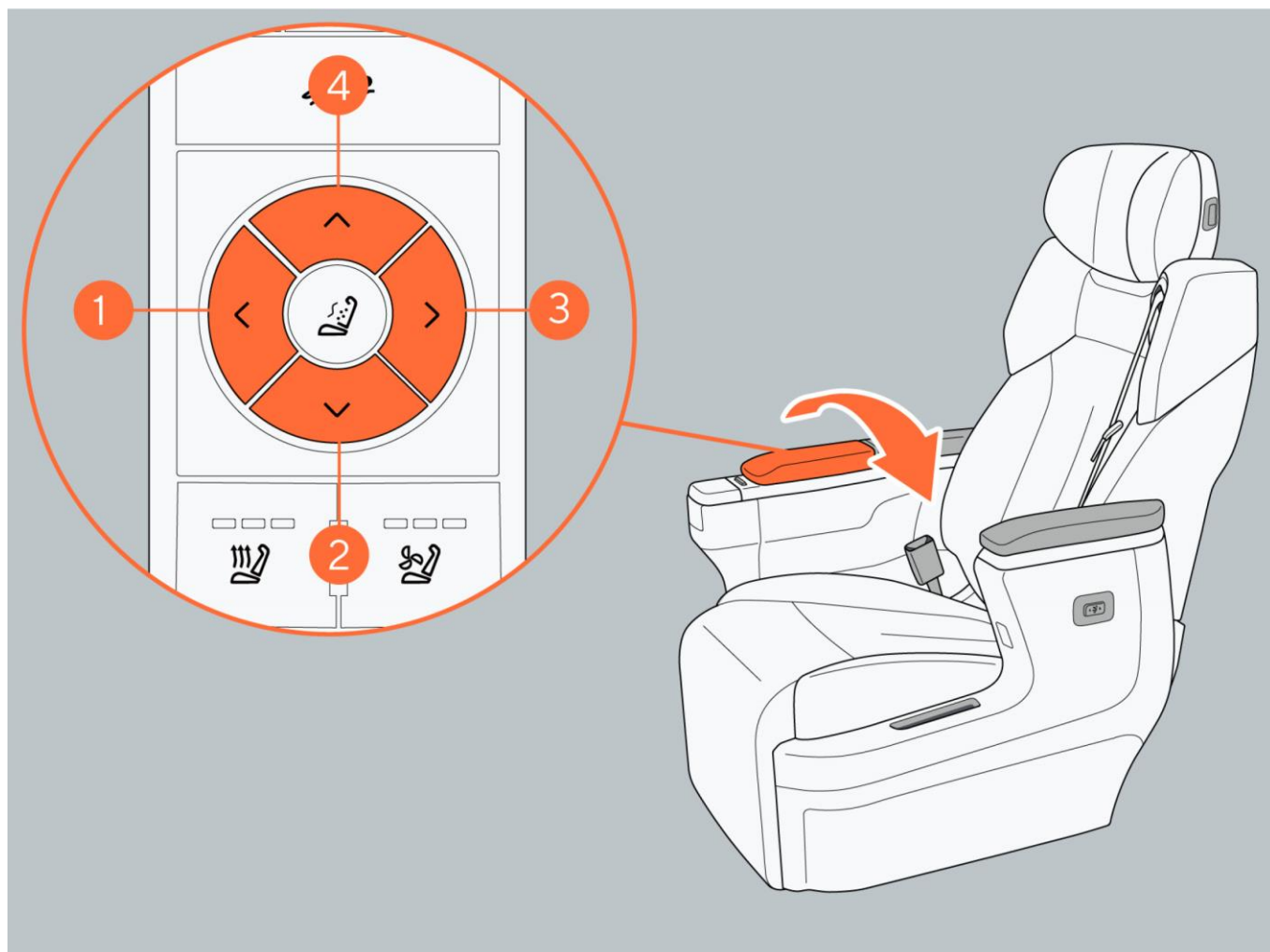

#### 4. Activate and deactivate seat massage with a button (aviation seat)

Activation: When the massage function is off, short press the massage button to activate the massage function.

Deactivation: When the massage function is on, short press the massage button to deactivate the massage function. When the massage function is on, operate the waist support adjustment button to deactivate the massage function.

## 6. Operation

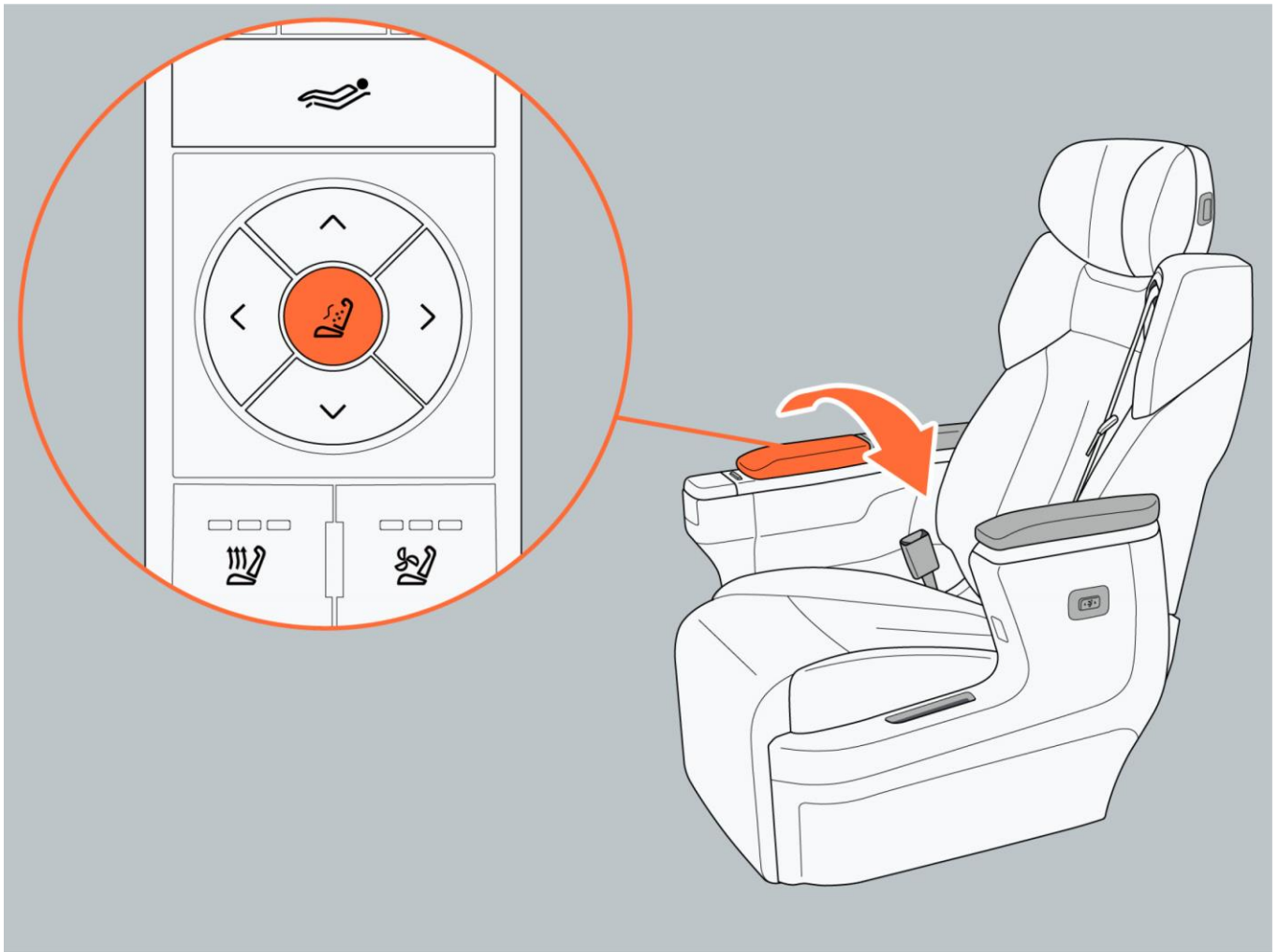

5. Activate and deactivate seat massage through the central control screen (aviation seat)

Click " A/C Control Interface → Seat" through the central control screen, and select the second-row left/right seat massage function. Activation: When the massage function is off, click Start Massage to activate the massage function.

Deactivation: When the massage function is on, click Close Massage to deactivate the massage function.

Massage intensity: There are three intensity options for seat massage intensity: strong, standard and gentle.

Massage mode: There are 9 seat massage modes for option, including: full circulation, back activation, back relaxation, back relief, spinal stretch, waist activation, waist stretch, full back relief and shoulder relaxation.

You can choose the seat massage mode according to your preference.



#### 6. Second-row seat one-click rest (aviation seat)

The one-button rest of the second row of seats can be turned on or off through the central control screen. Click "Vehicle Settings → Vehicle → Seat → Comfort Mode" through the central control screen to set the activation and deactivation of second-row seat one-click rest.

Or press the "One-click Rest" button of the second-row seat, and the seats will automatically adjust the front and rear directions, seat angles, and leg rest positions, so that they can move to the set position of resting and lying flat. When using the "One-click Rest" function, ensure that there are no occupants in the first and third rows, and the vehicle is in P gear.

#### Warning

- Do not tilt the seat too much during driving, to avoid the waist seat belt may slip over the hip in an accident and directly cause the abdomen to be strangled, or the shoulder seat belt may contact with the neck, resulting in serious injury or death to the occupant.

#### Tip

- During the one-click rest adjustment or in the one-click rest mode, adjust any position of the seat to stop adjusting the one-click rest mode and maintain the current position. Press the one-click rest button again to exit the one-click rest mode.

## 6. Operation

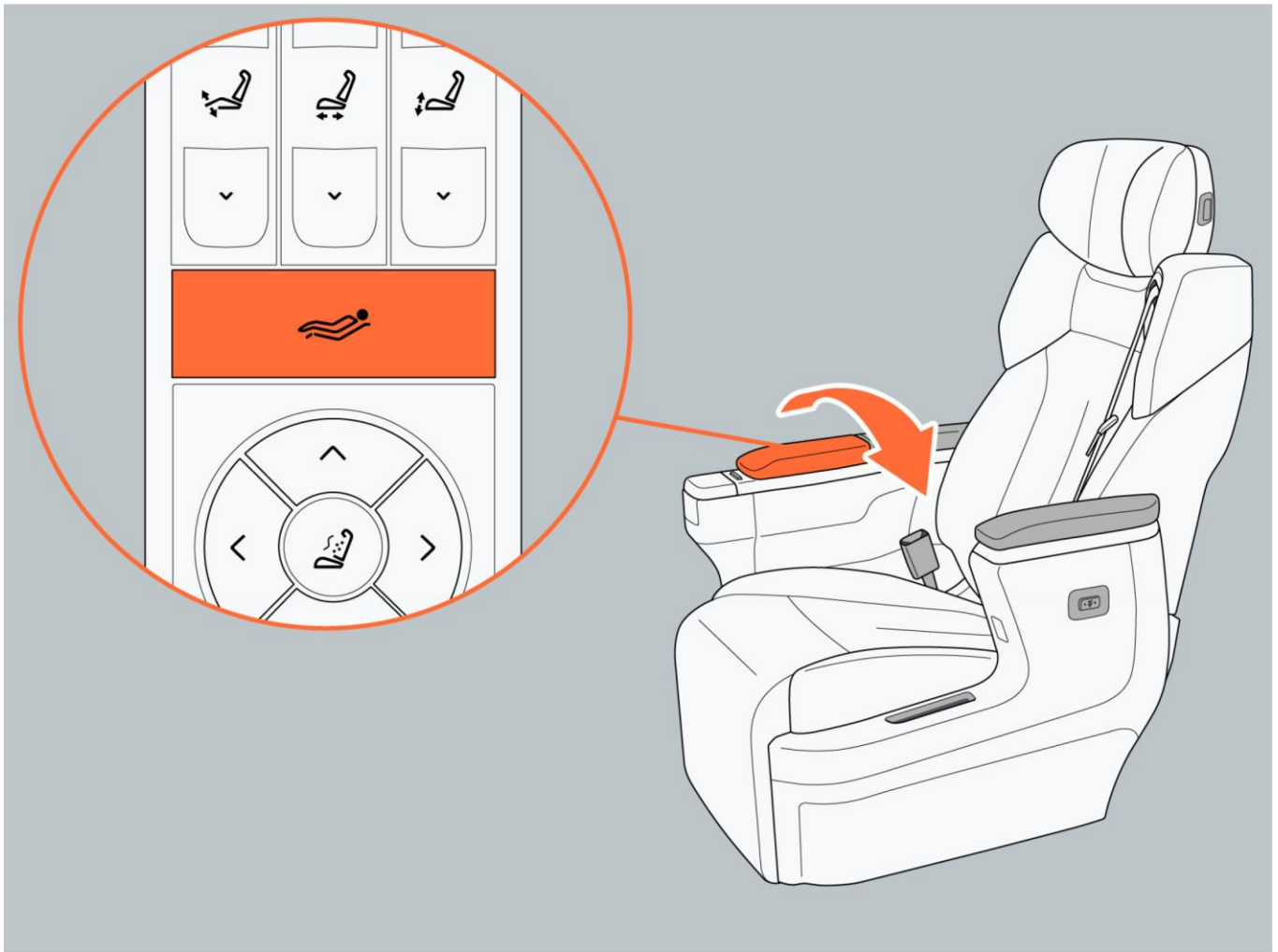

### 7. Second-row easy entry (aviation seat)

When the gear is in P position and there are no occupants in the second-row seat, press the front end of the “One-click Entry” button, and the second-row seat will automatically adjust the backrest angle, leg rest angle, and seat angle while the seat moves forward to the set position, facilitating people to enter and exit. Press the rear end of the “One-click Entry” button to restore the seat to the set position.

#### Caution

- When using the easy access function, do not place items on the seat to avoid damaging the seat.
- When using the easy entry function, do not allow people to sit on the seat to avoid pinching.

#### Tip

- In the process of easy entry adjustment, operate any switch of the second-row seat to facilitate the exit of the easy entry function.
- In the process of easy entry adjustment, when it is detected that there are occupants in the second-row seat, the easy entry function stops, and the seat stops moving.
- In the process of easy entry adjustment, press the easy entry button to pause the easy entry function. Re-press the easy entry button within 30 s to continue to execute the easy entry function.



The function exits after over 30 s.

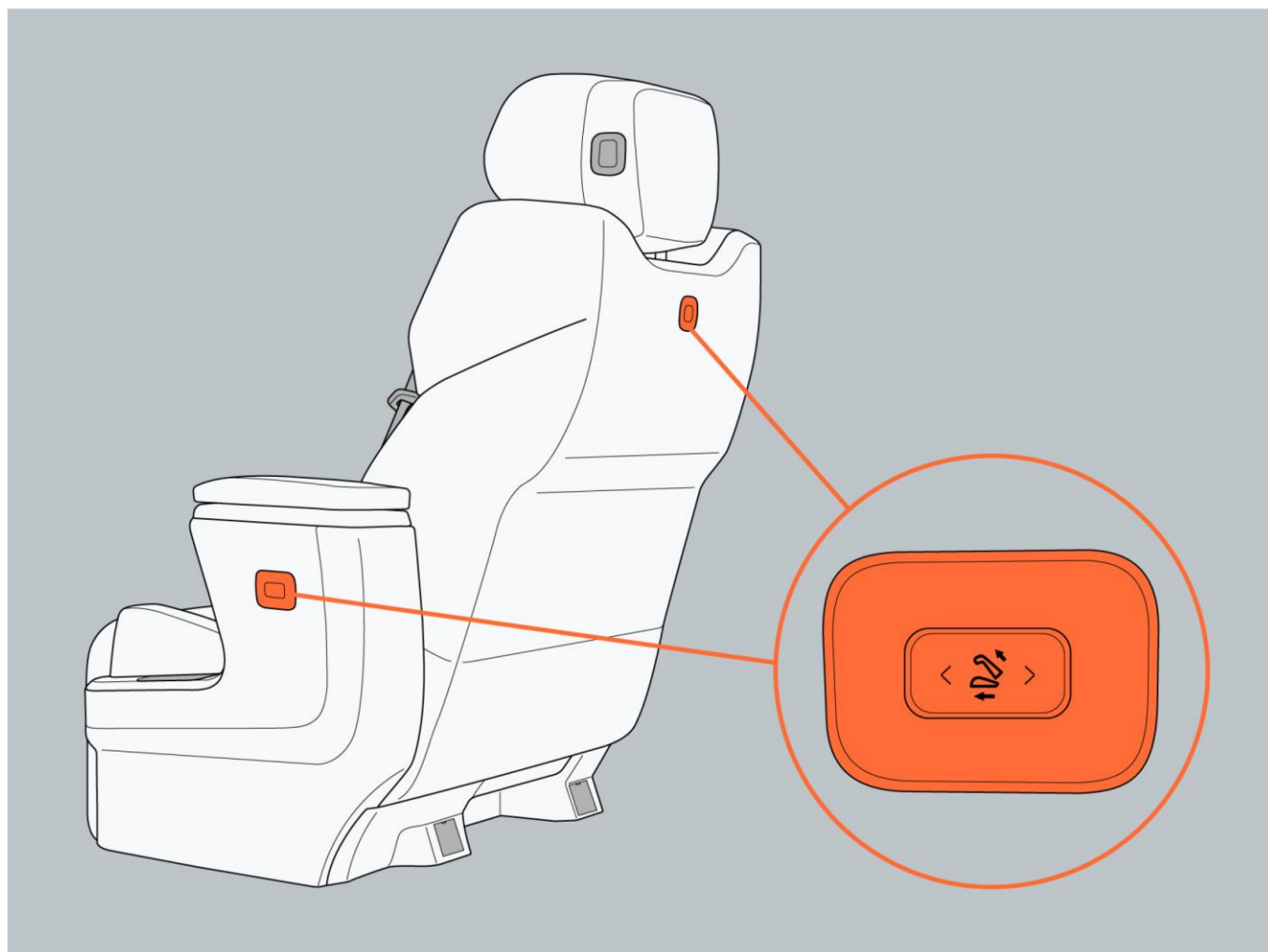

### III. Seat position parameter

Seat backrest angle: 25°

Common seat travel: 70 mm forward; 70 mm backward.

Aviation seat travel: 230 mm forward; 110 mm backward.

## 6.3.3 Third row seats

### I. Fold down the seat backrest

1. Adjust the third-row seat headrests to the lowest position.
2. Push the shoulder unlock handle upwards, and the seat backrest folds forward.

#### **i** Tip

- When folding down the third-row seats, if the second-low seat interferes with the folding down/lifting of the third-row seat backrest, first move the second-row seat forward to a position that does not interfere, and then carry out the folding down/lifting action.
- The seat backrest can be adjusted appropriately by shoulder unlock handle.

## 6. Operation

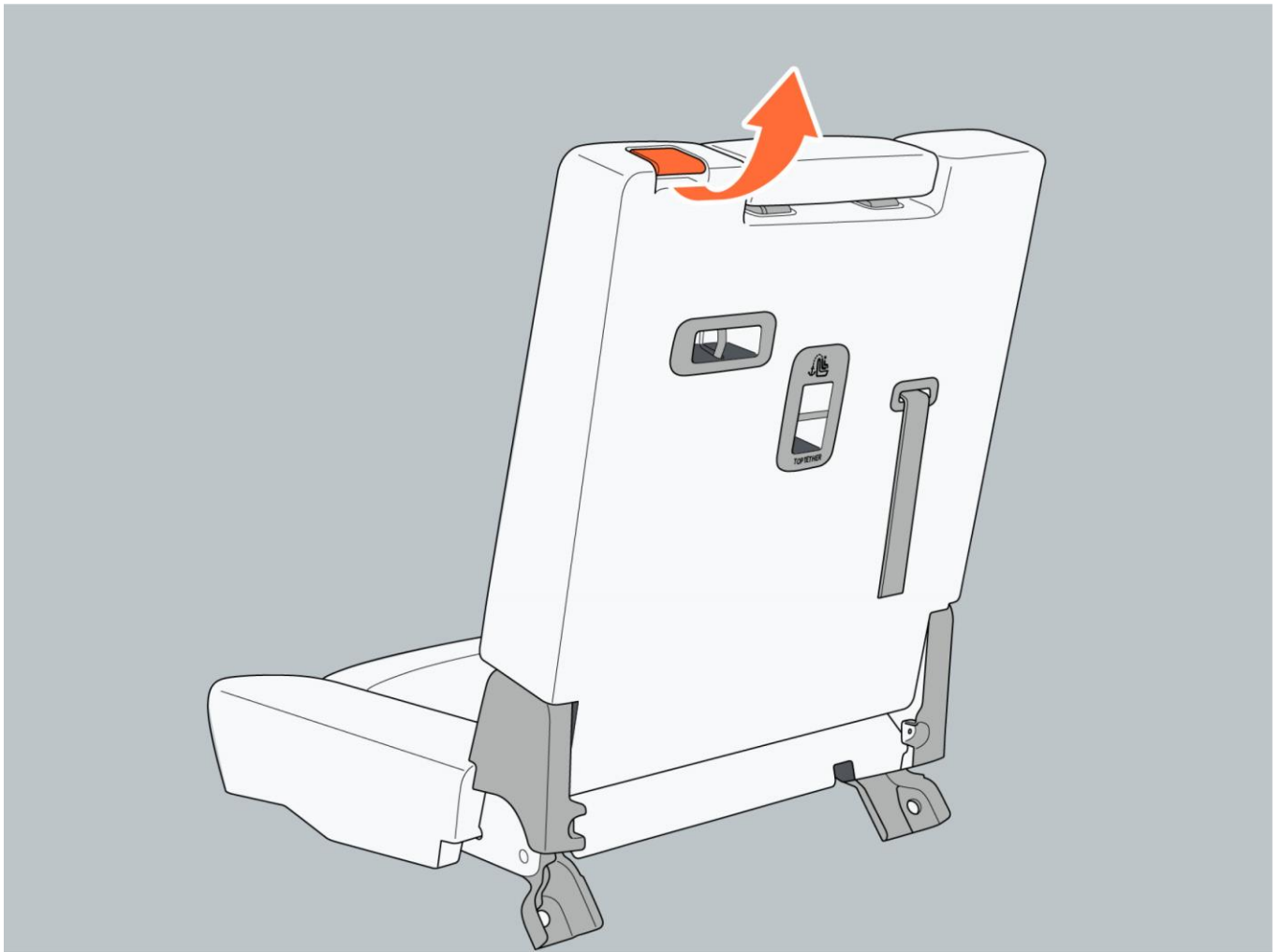

### II. Lift the seat backrest

Lift the seat up to the seat locked position until you hear a “click” sound. After the seat is lifted, shake the seat slightly back and forth to ensure that the seat is locked.

#### Caution

- Before folding the seat backrest, make sure that the seat belt is in an unfastened state to avoid damaging the seat or seat belt.
- Before folding the seat backrest, make sure that there are no items in the third-row foot area and the seat to avoid damaging the seat or other items.



### 6.3.4 Headrest

The headrest is an important part of protecting the driver and passengers. Correctly adjusting the seat headrest can effectively reduce the injury to the neck in case of a collision.

#### I. Headrest height

Adjust the seat headrest according the height to make the ears flush with the center of the headrest, ensuring that the entire head is well supported.

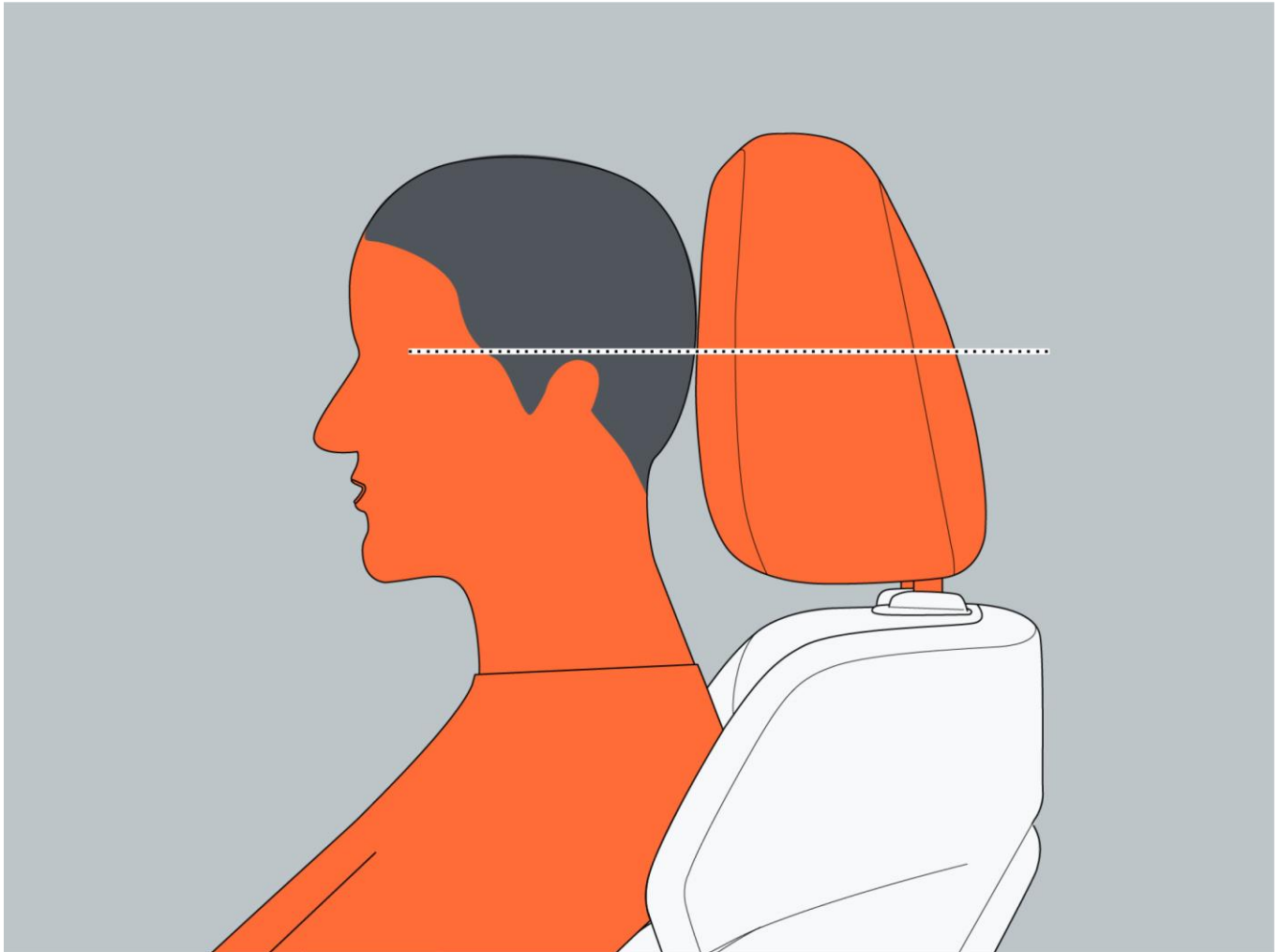

#### II. Front row headrest height adjustment (common seat)

Upward adjustment: Pull up the headrest to the desired position, and the adjustment is completed. After adjusting to the desired position, press the headrest again to ensure that the headrest is locked.

Downward adjustment: Press the lock unlocking button, press the headrest down to the desired position, and then release the lock unlocking button to complete the adjustment. Press the headrest again after adjusting it to the desired position. Make sure that the headrest is locked.

#### **i** Tip

- The adjustment method of the second-row common seat headrests is the same as that of the front-row headrest.

## 6. Operation

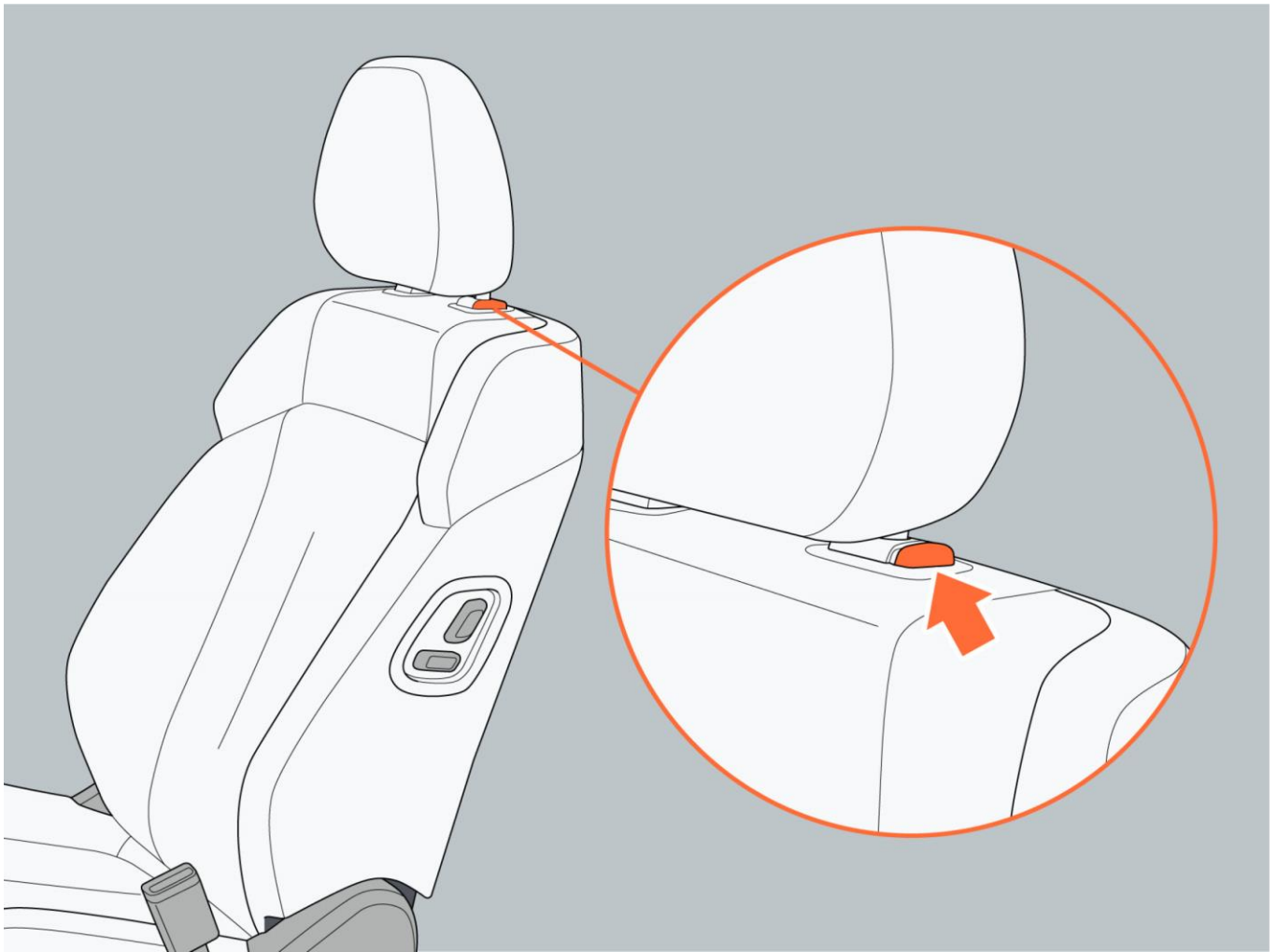

### III. Second-row headrest adjustment (aviation seat)

Upward adjustment: Pull up the headrest to the desired position, and the adjustment is completed. After adjusting to the desired position, press the headrest again to ensure that the headrest is locked.

Downward adjustment: Press the headrest side lock unlocking button, press the headrest down to the desired position, and then release the lock unlocking button to complete the adjustment. After adjusting to the desired position, press the headrest again to ensure that the headrest is locked.

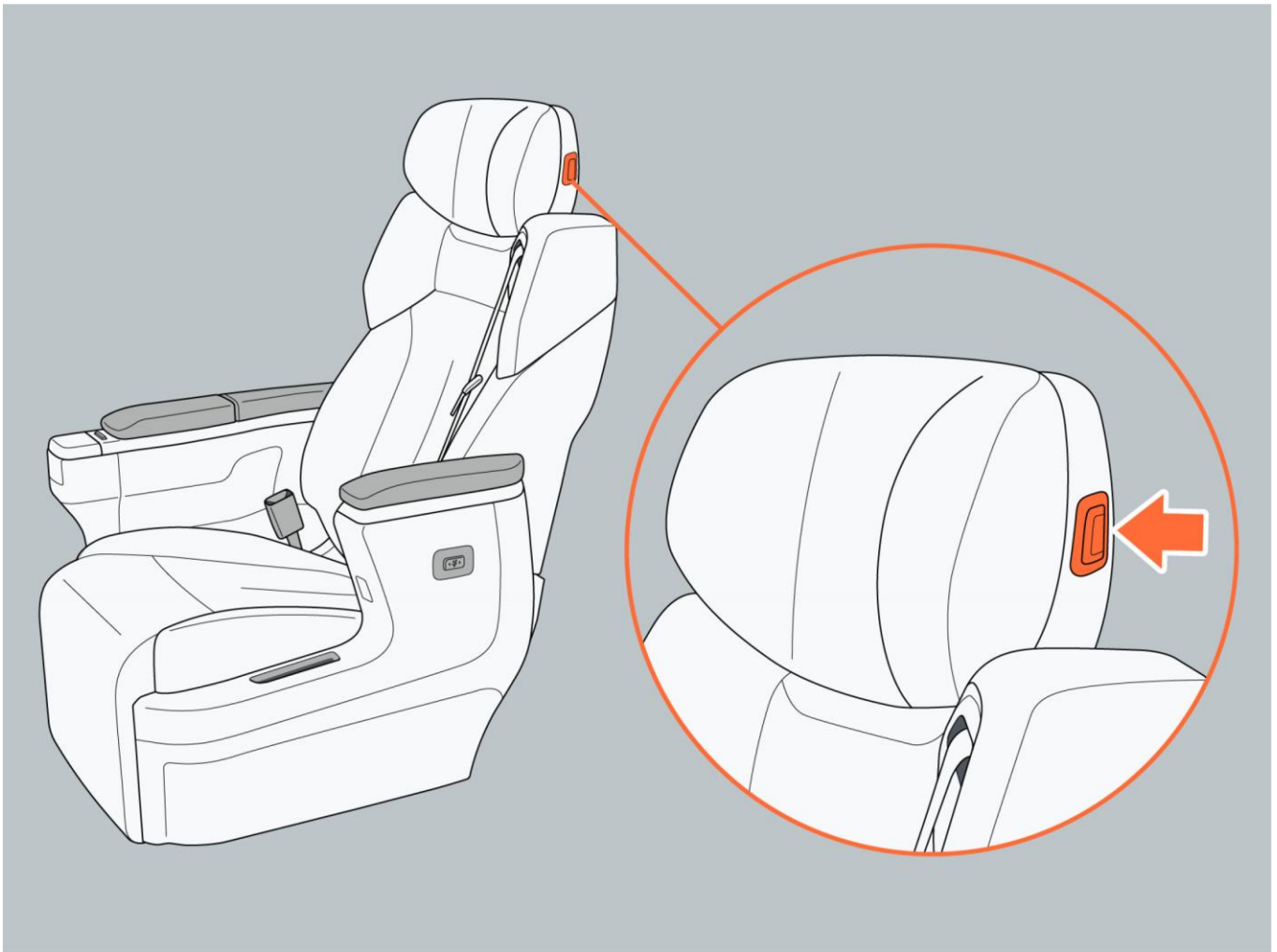

#### IV. Third-row headrest adjustment

Upward adjustment: Pull up the headrest to the desired position, press the headrest again after adjusting it to the desired position. Ensure that the headrest is locked.

Downward adjustment: Press the lock unlocking button, press the headrest down to the desired position, and then release the lock unlocking button to complete the adjustment. Press the headrest again after adjusting it to the desired position. Make sure that the headrest is locked.

#### **i** Tip

- When using the third-row seat headrest, adjust the headrest upwards to the use position. The lowest position is the non-use position.

#### V. Headrest disassembling

Remove the headrest: Press the lock unlocking button on both sides while pulling up the headrest to remove the headrest.

Install the headrest: After the headrest is aligned with the installation hole, press the unlock button and press down to the desired position. After the installation is completed, press the headrest again to ensure that the headrest is locked.

## 6. Operation

### Warning

- Do not replace the headrest with the one from another vehicle.
- Do not adjust the seat headrest while driving.
- Please adjust the headrest to the appropriate position before driving. This can reduce the injury to the neck in case of a collision.

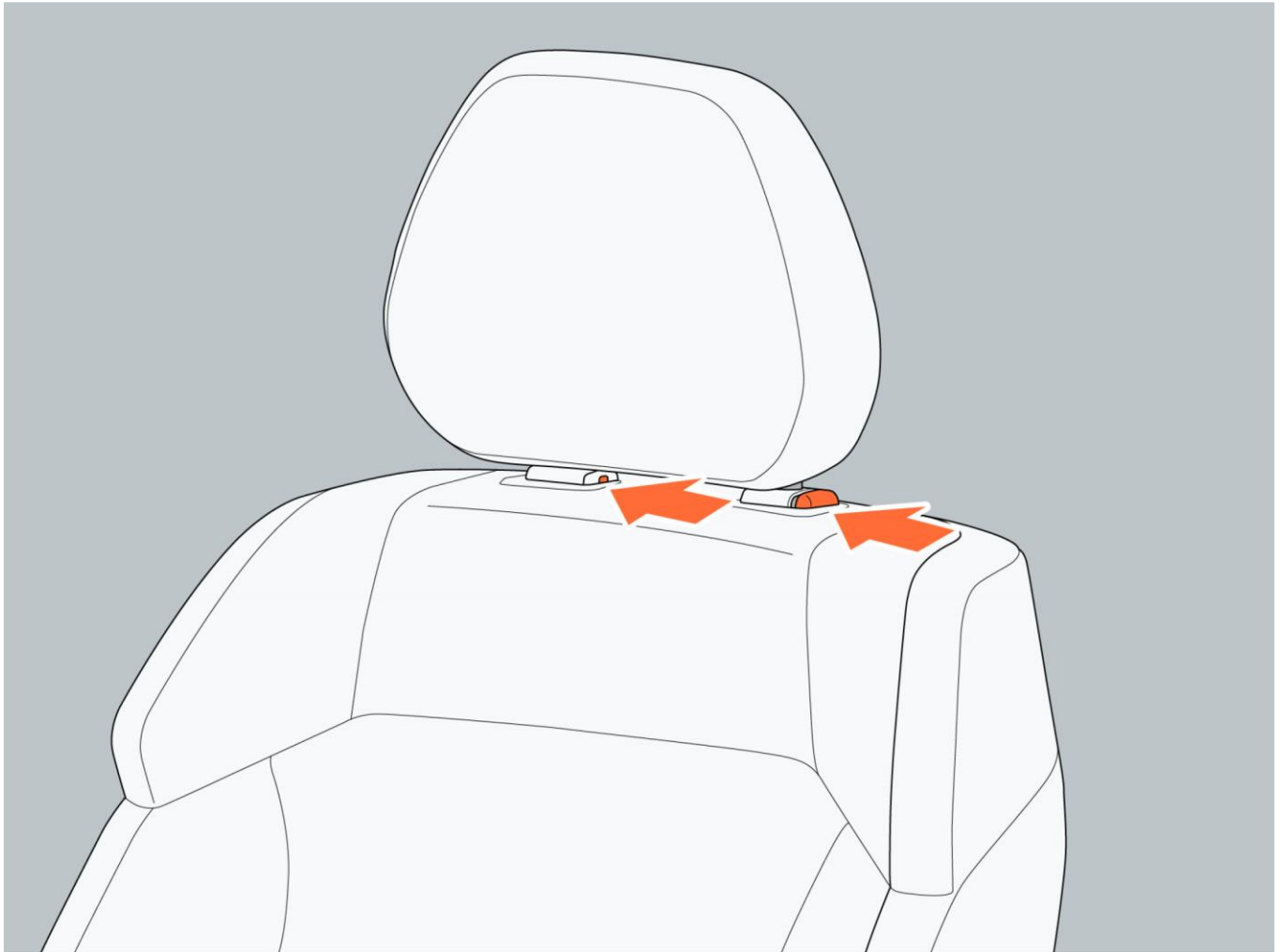

## 6.4 Adjustment of steering wheel and rearview mirror

### 6.4.1 Steering wheel

#### I. Adjustment of steering wheel

1. Push the steering wheel lock handle 1 down to unlock the steering wheel.
2. Adjust the steering wheel position up, down, back and forth according to the needs.
3. Pull the steering wheel lock handle 1 up to lock the steering wheel. Shake the steering wheel after adjustment is completed to ensure that the steering wheel is firmly locked.

#### Warning

- Do not adjust the steering wheel during driving to avoid accidents.
- After adjusting the steering wheel, be sure to lock the steering wheel to prevent it from shifting during driving.

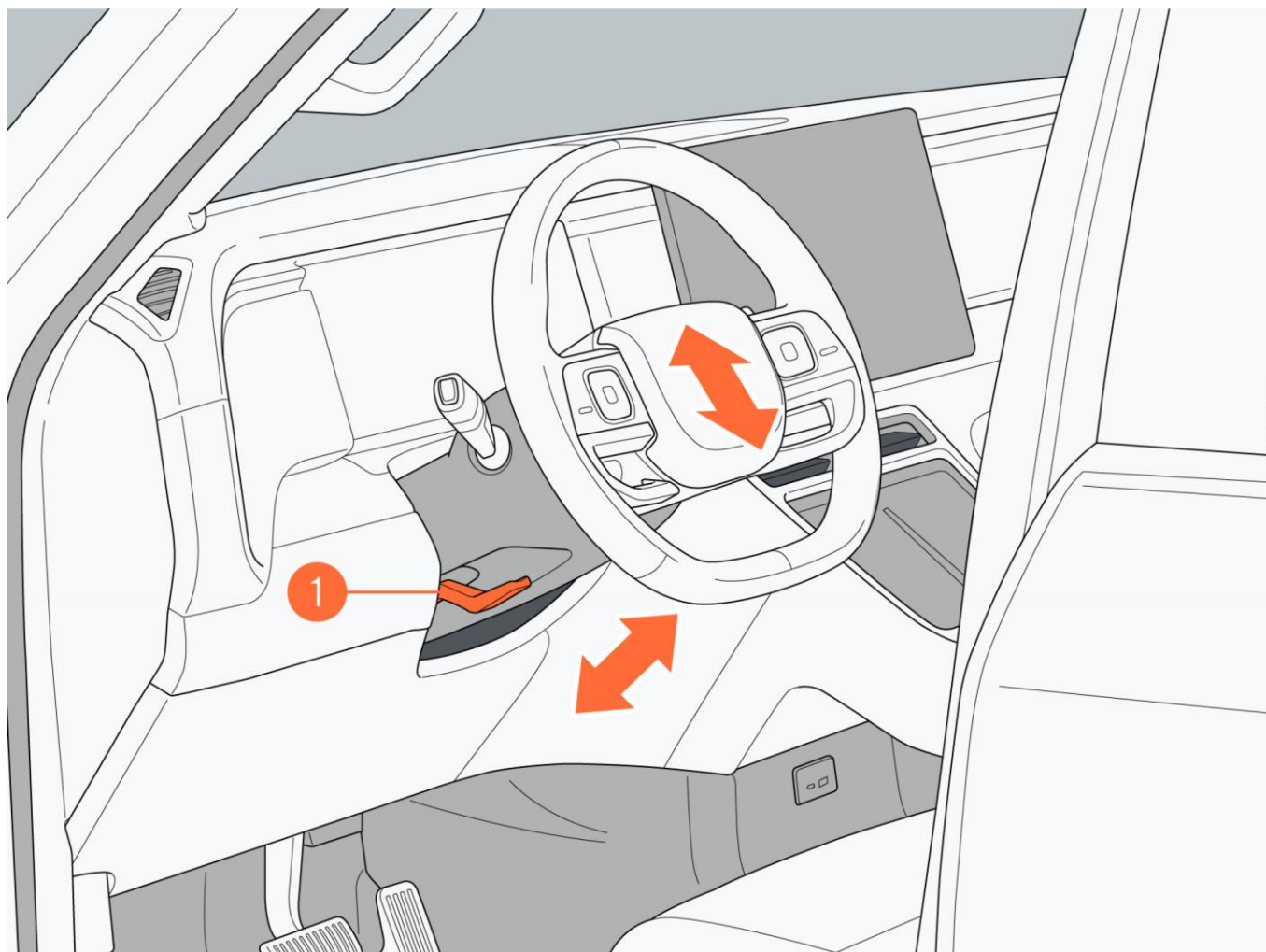

## 6. Operation

### II. Horn

Press the horn switch in the middle of the steering wheel, and the horn will sound. Release the horn switch and the horn stops honking.

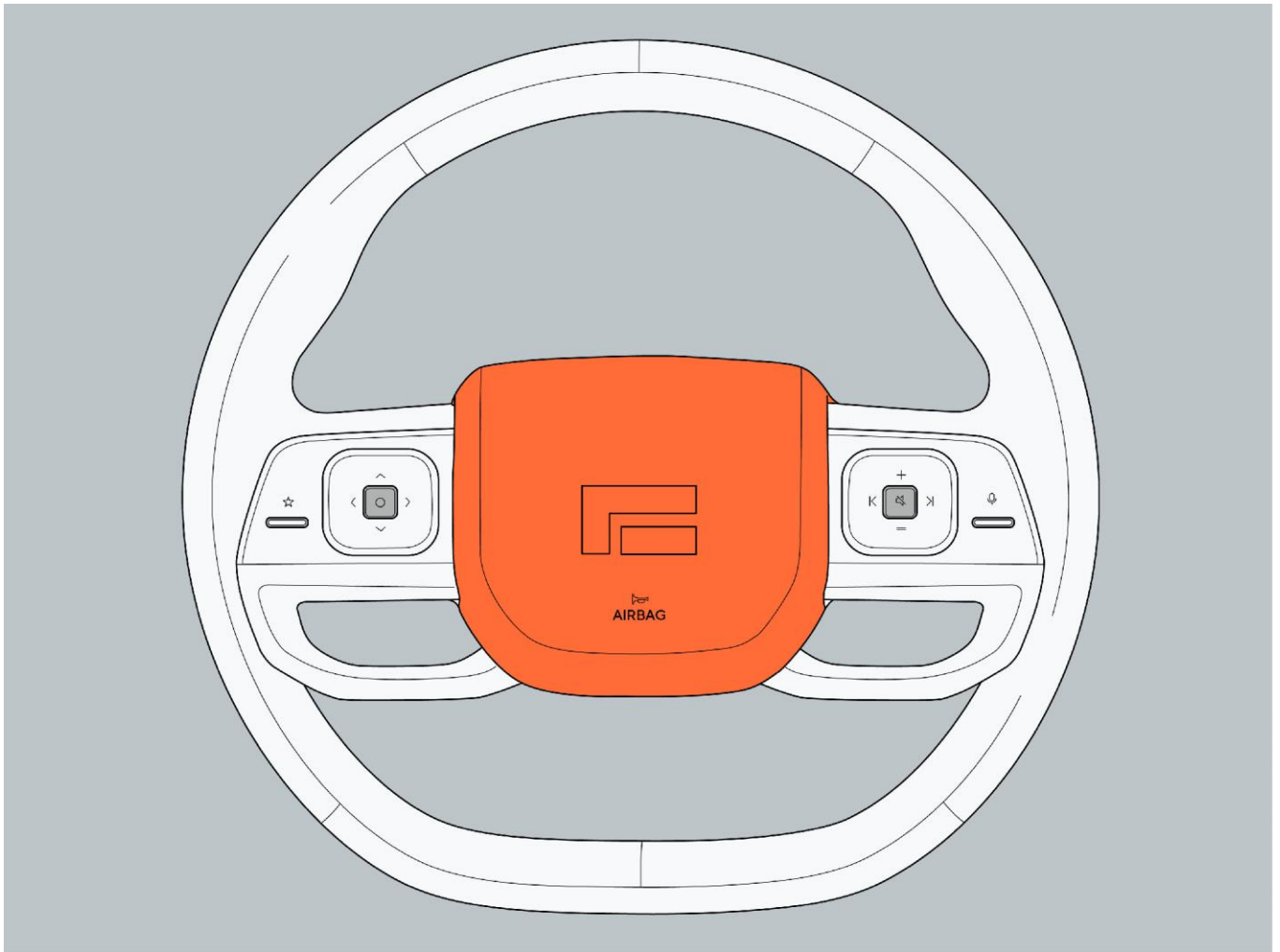

### III. Steering wheel left button

1. Custom buttons: Set custom buttons by clicking “Vehicle Settings → Vehicle → Steering Wheel” through the central control screen, including: AVM, playback sound source switching, ceiling screen switch and emergency video recording. After the setting is completed, short press the button to realize the corresponding function.
2. Confirm key: Short press to answer/hang up the phone, hide the alarm information on the instrument side, and edit the status of the entry/exit menu function. Long press to refuse to answer the phone.
3. Upper key: Short press to increase the A/C temperature or switch the card function on the left side of the instrument screen.
4. Left button: Short press to reduce the A/C air volume.
5. Right button: Short press to increase the A/C air volume.
6. Lower key: Short press to decrease the A/C temperature or switch the card function on the left side of the instrument screen.

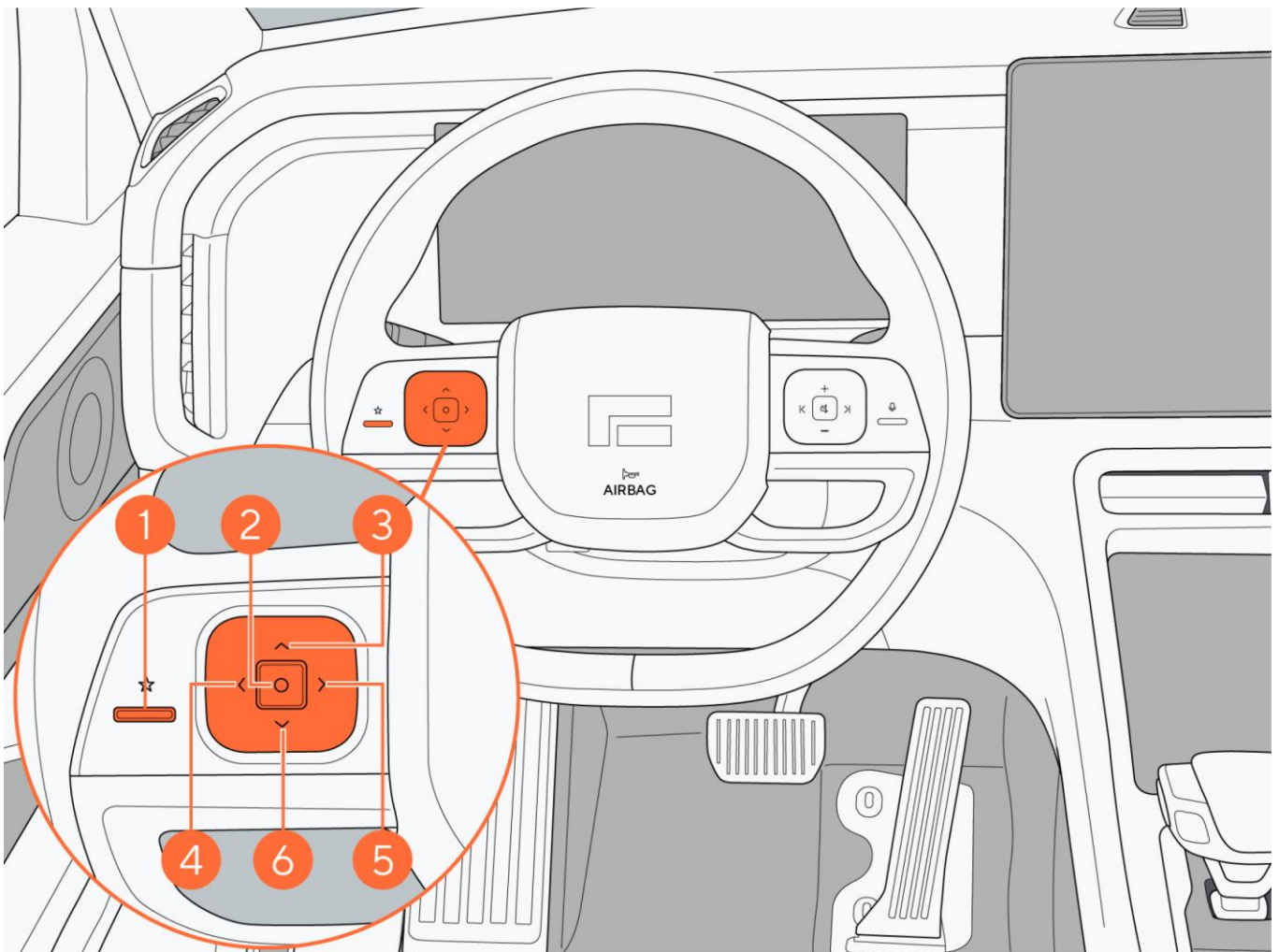

### IV. Steering wheel right key

1. Voice key: Short press to wake up/exit the voice function.
2. Mute key: Short press to mute multimedia (default), calls, and navigation broadcasts.



## 6. Operation

3. Volume increase key: Short press to adjust the volume of multimedia, call volume and navigation volume, or adjust the function switch of the card on the right side of the instrument.
4. Left key: Short press to adjust to the last track of the media music, or last video/radio channel.
5. Right key: Short press to adjust to the next track of the media music of the last video/radio channel next.
6. Volume decrease key: Short press to decrease the volume of multimedia, call volume and navigation volume, or adjust the function switch of the card on the left side of the instrument.

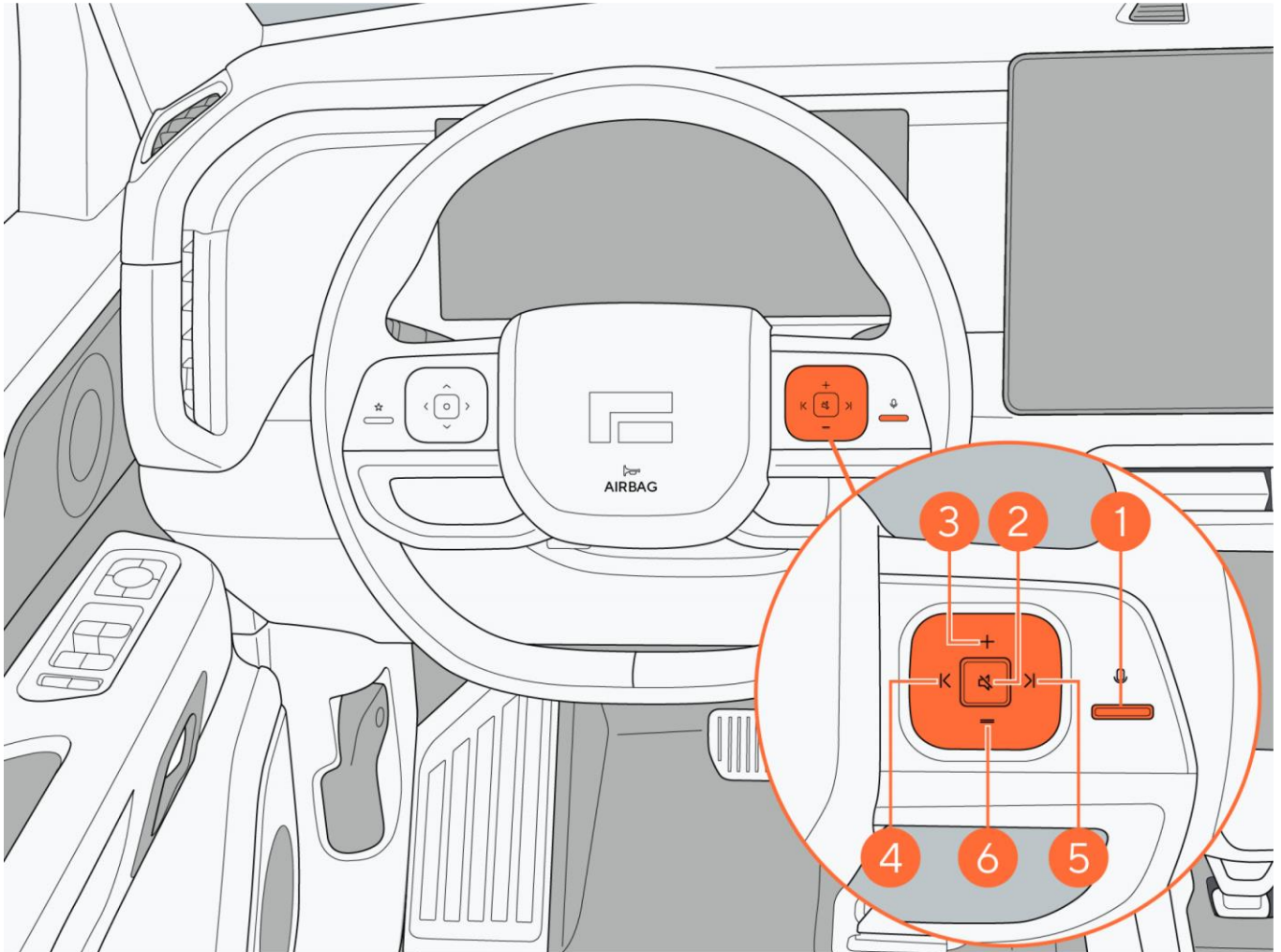



### V. Restart the car computer system

If the car computer system crashes, you can long press the custom button 1 and voice button 2 at the same time (about 10 s) to restart the central control screen and instrument screen.

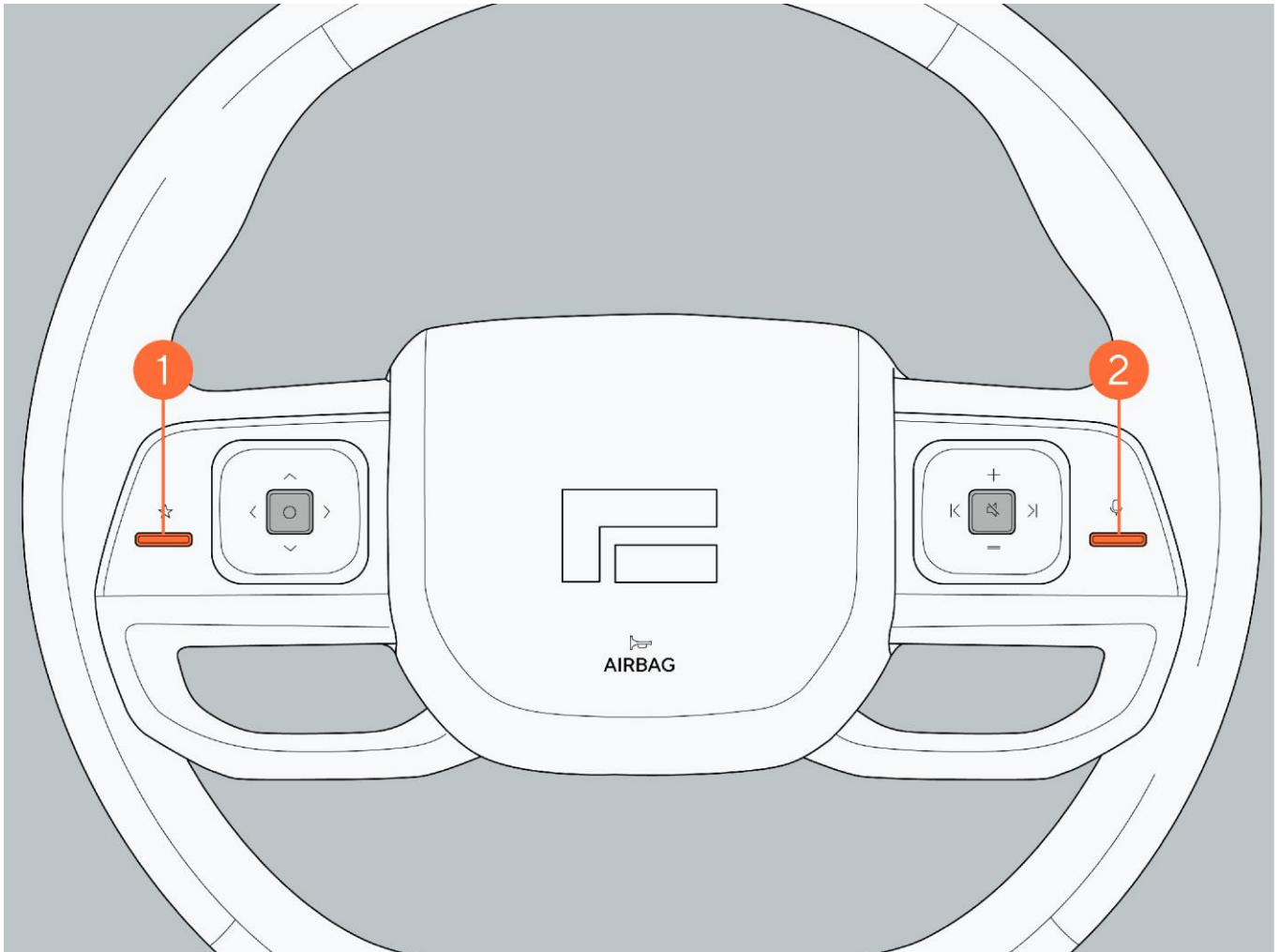

## 6. Operation

### 6.4.2 Interior rearview mirror

#### I. Adjust the position of the interior rearview mirror

Before driving the vehicle, manually adjust the interior rearview mirror up, down, left and right to the appropriate angle according to the driving sitting posture.

#### Warning

- Do not install items or decorations that affect the line of sight around the interior rearview mirror. This will avoid affecting the driver's observation of road conditions.
- Do not adjust the interior rearview mirror during driving. This will avoid loss of control of the vehicle due to distracting, resulting in casualties or vehicle damage.

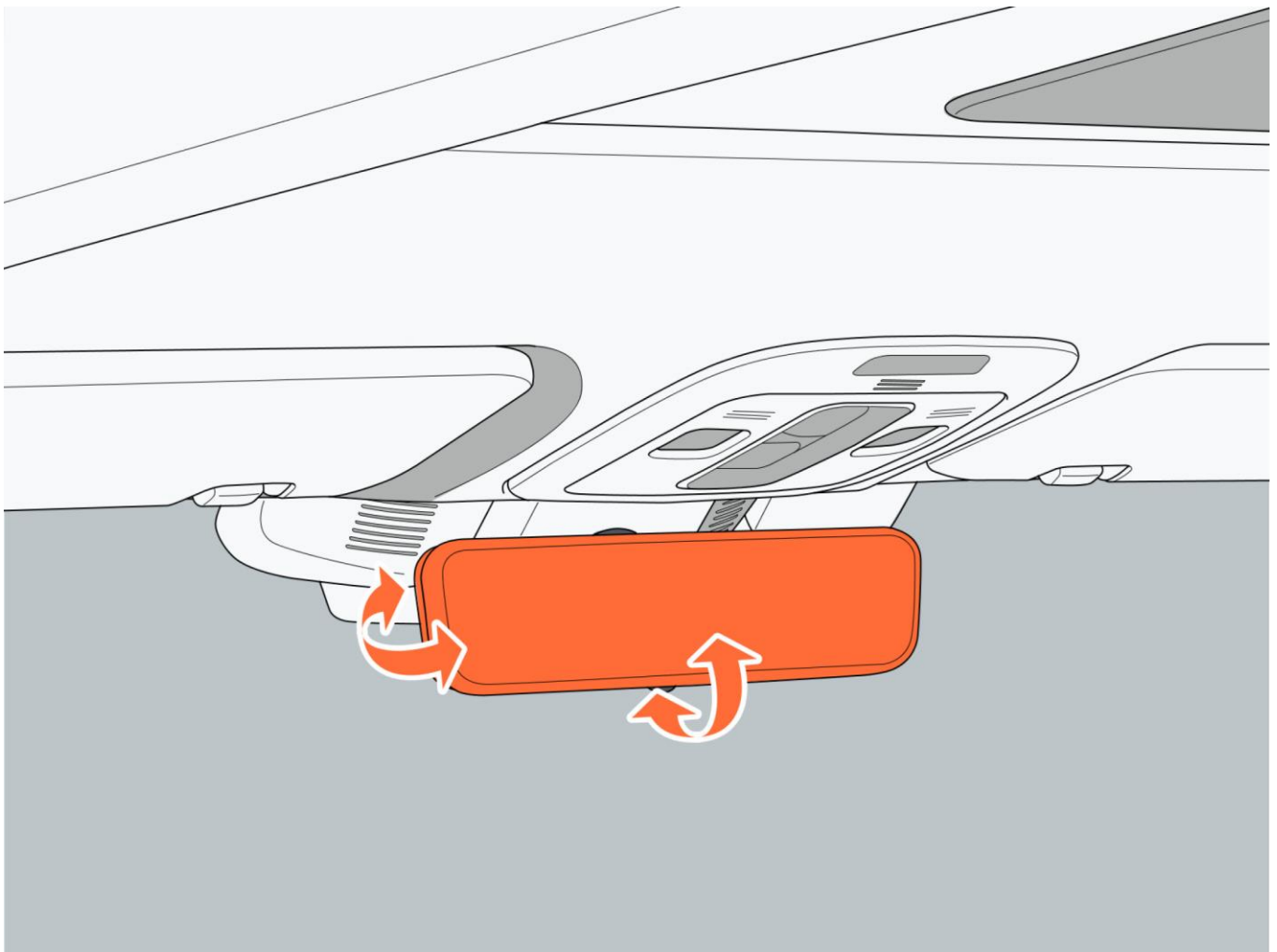

#### II. Auto anti-dazzling function

When driving at night, the interior rearview mirror sensor automatically dims the mirror surface of the interior rearview mirror according to the light intensity of the rear vehicle.

When the vehicle power supply is in "READY" or "ON" mode, the auto anti-dazzling function is activated. When the vehicle switches to R gear, the auto anti-dazzling function exits.

### III. Anti-dazzle sensor

Keep the surface of the front and rear anti-dazzling sensors of the interior rearview mirror clean and away from obstacles to ensure the normal operation of the auto anti-dazzling function.

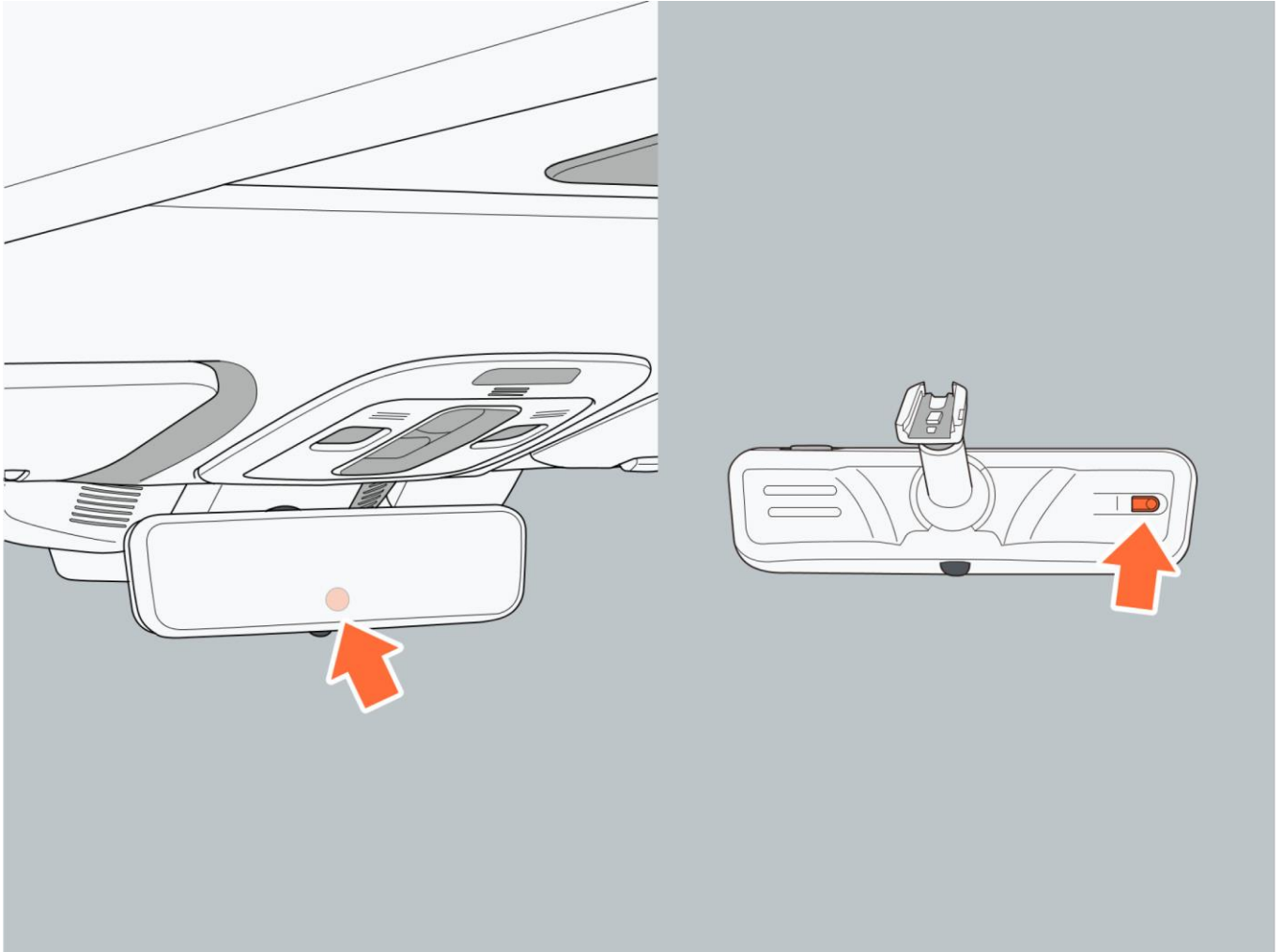

## 6. Operation

### IV. Stream media rearview mirror

#### 1. Entering stream media mode

Pull the lower lever of the interior rearview mirror inward to turn on the display and enter stream media mode.

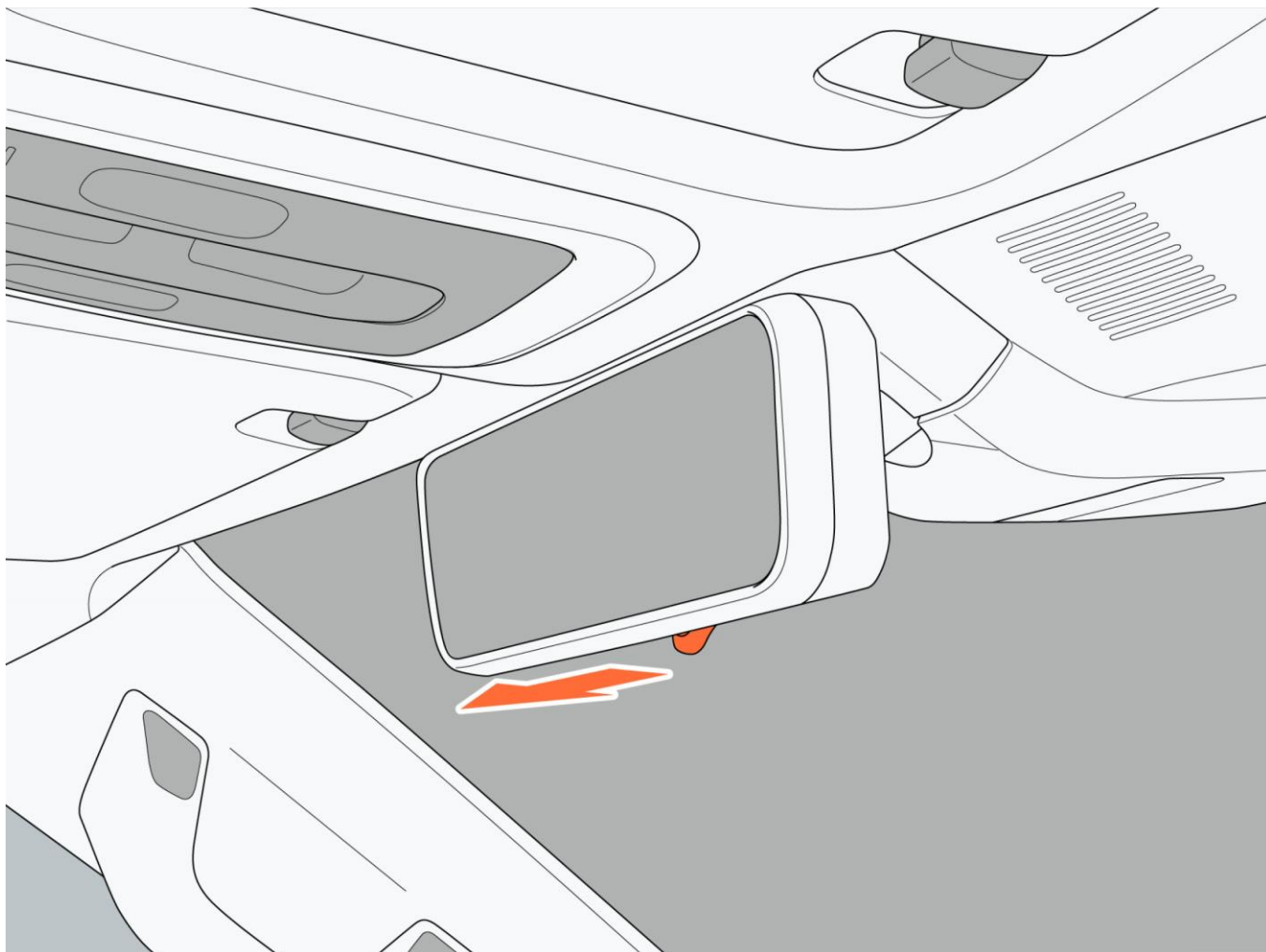

### 2. Exiting stream media mode

Pull the lower lever of the interior rearview mirror outward to turn off the display screen, exit the streaming media mode. The interior rearview mirror will automatically dim. At this time, the interior rearview mirror can be used as a traditional interior rearview mirror.

After exiting the stream media mode, you need to adjust the interior rearview mirror so that you can clearly see the rear area of the car.

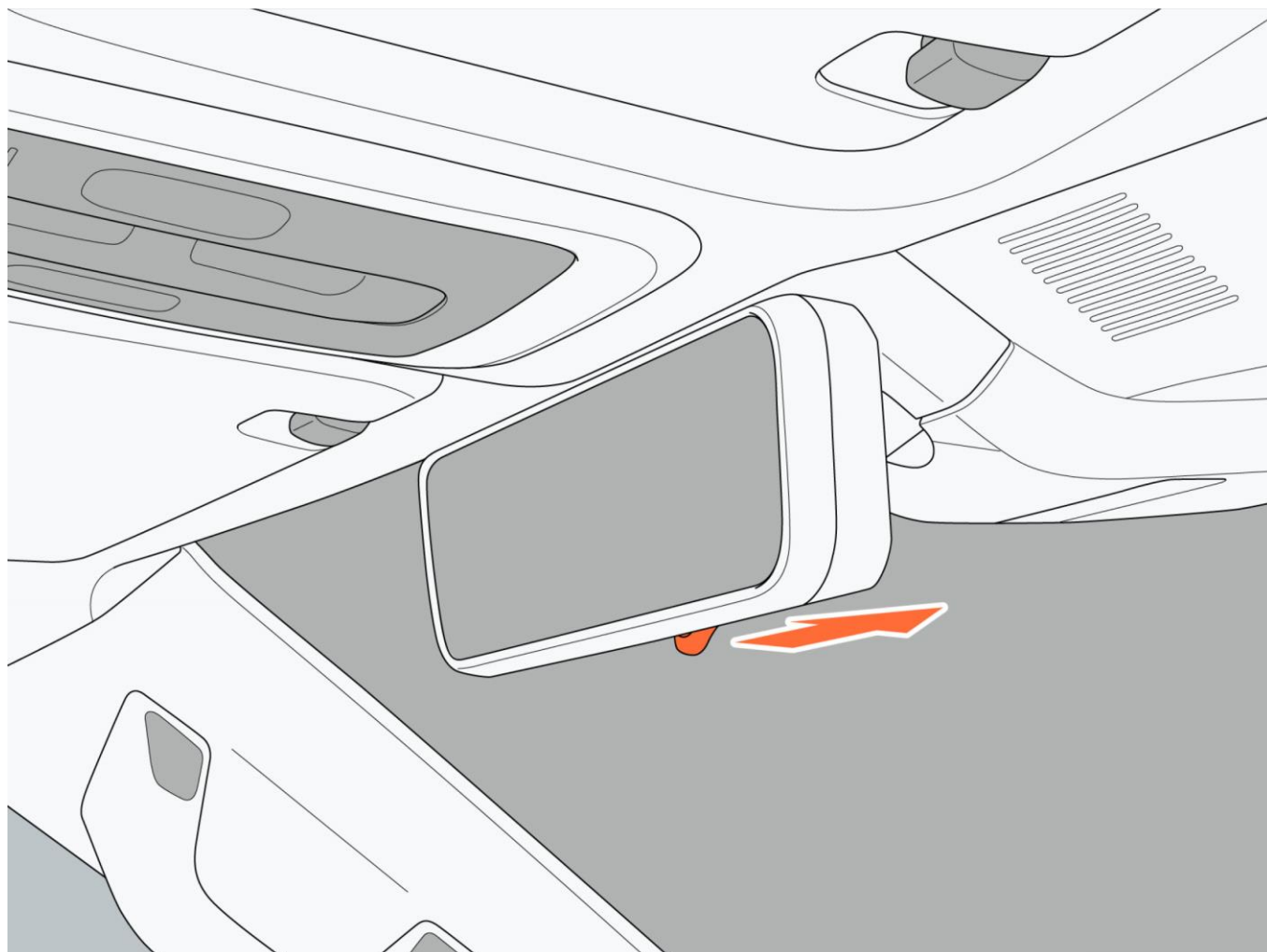

### 3. Function setting

Function settings include brightness adjustment, angle adjustment, far and near zoom and color temperature adjustment. In each setting item, scan the code by pressing button 2 and button 3 at the same time to view the manual.

- Brightness adjustment

In the streaming media mode state, press button 1 to enter brightness adjustment, and press button 2 and button 3 to perform brightness adjustment settings. To switch other settings, press button 1.

- Angle adjustment

In the streaming media mode state, press button 1 twice in succession to enter the angle adjustment, and press button 2 and button 3 to perform the angle adjustment setting. To switch other settings, press button 1.

- Far and near zooming

## 6. Operation

In the streaming media mode state, press button 1 for three times in succession to enter brightness adjustment, and press button 2 and button 3 to perform far and near zooming adjustment settings. To switch other settings, press button 1.

### Warning

- Do not operate the stream media function during driving, so as not to affect driving safety. If you need this operate, please park the vehicle in a safe area before performing relevant operations.

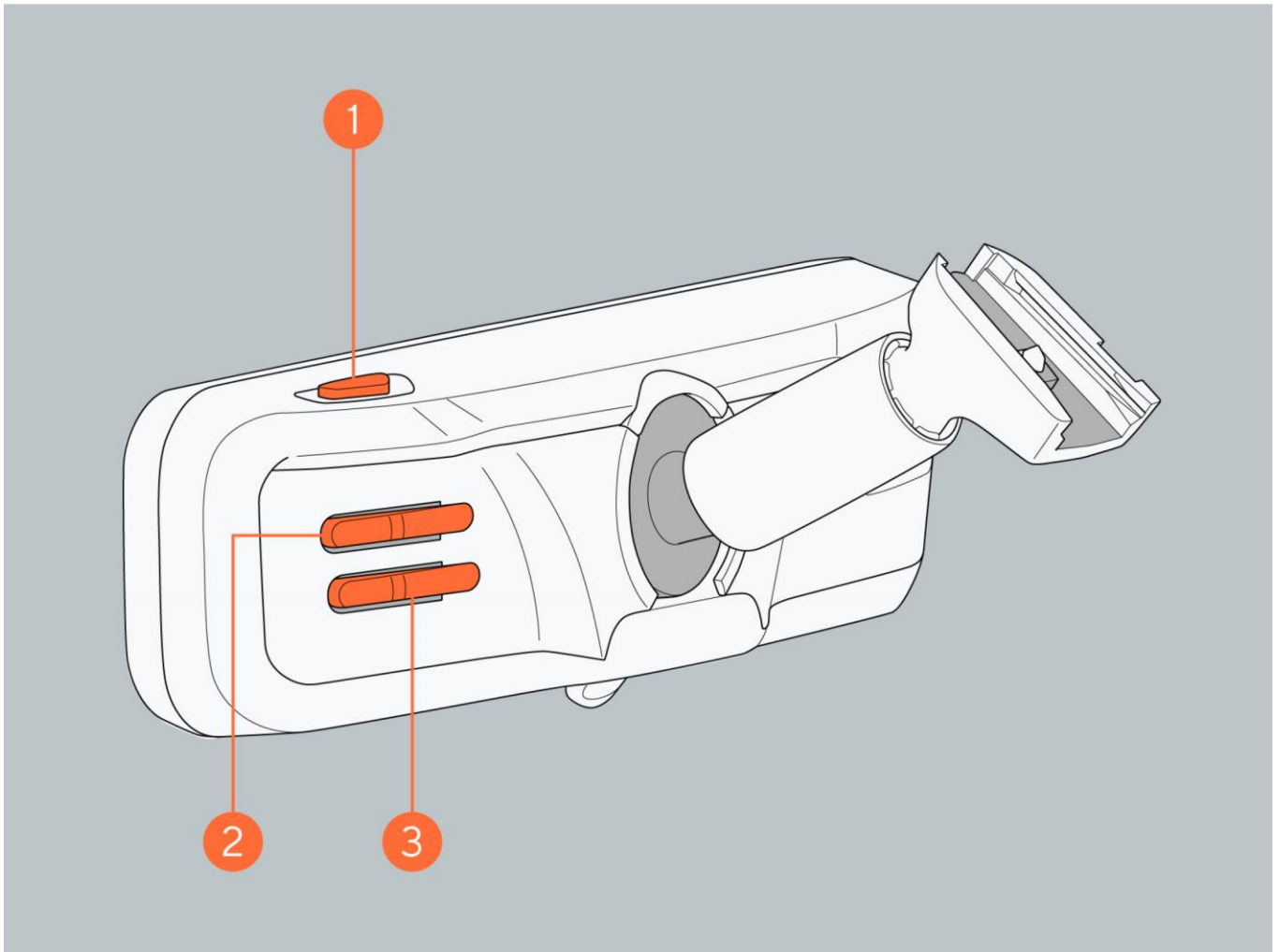

### V. Functional limitation

Stream media interior rearview mirrors may not function or display a clear image if:

The sun reflects or the headlamps of the rear car cause dazzling, or obstacles block the view.

The camera lens is clogged by dust, snow, or other debris. Clean the lens with a soft, damp cloth.

The vehicle was damaged and the position and installation angle of the camera changed.

### Warning

- If the stream media function fails, pull the lever to exit the stream media mode and switch to the traditional rearview mirror for use. At the same time, contact ROX Service Center.
- The stream media function cannot replace the driver's judgment of the external situation. Do not

only observe the interior rearview mirrors when driving or parking. Under any circumstances, the driver should be responsible for the safety of the vehicle and observe the surrounding conditions of the vehicle at any time.

### 6.4.3 Exterior rearview mirror

I. Adjust the mirror position of the exterior rearview mirror

Select the rearview mirror that needs to be adjusted through the buttons on the driver's side:

1. Click button 1 to activate the left rearview mirror. When it is activated, the button will display red. If there is no operation in 60 s, the activated state will be automatically turned off.
2. Click button 2 to activate the right rearview mirror. When it is activated, the button will display red. If there is no operation in 60 s, the activated state will be automatically turned off.

After selecting the corresponding exterior rearview mirror, press the button 3 to adjust the lens of the exterior rearview mirror up, down, left and right:

↑ : Adjust the rearview mirror lenses upwards.

↓ : Adjust the rearview mirror lenses downwards.

← : Adjust the rearview mirror lenses to the left.

→ : Adjust the rearview mirror lenses to the right.

#### Warning

- Do not adjust the exterior rearview mirror during driving. This will avoid loss of control of the vehicle, resulting in casualties or vehicle damage.
- Do not drive your vehicle when the exterior mirrors are not adjusted to the appropriate position.



## 6. Operation

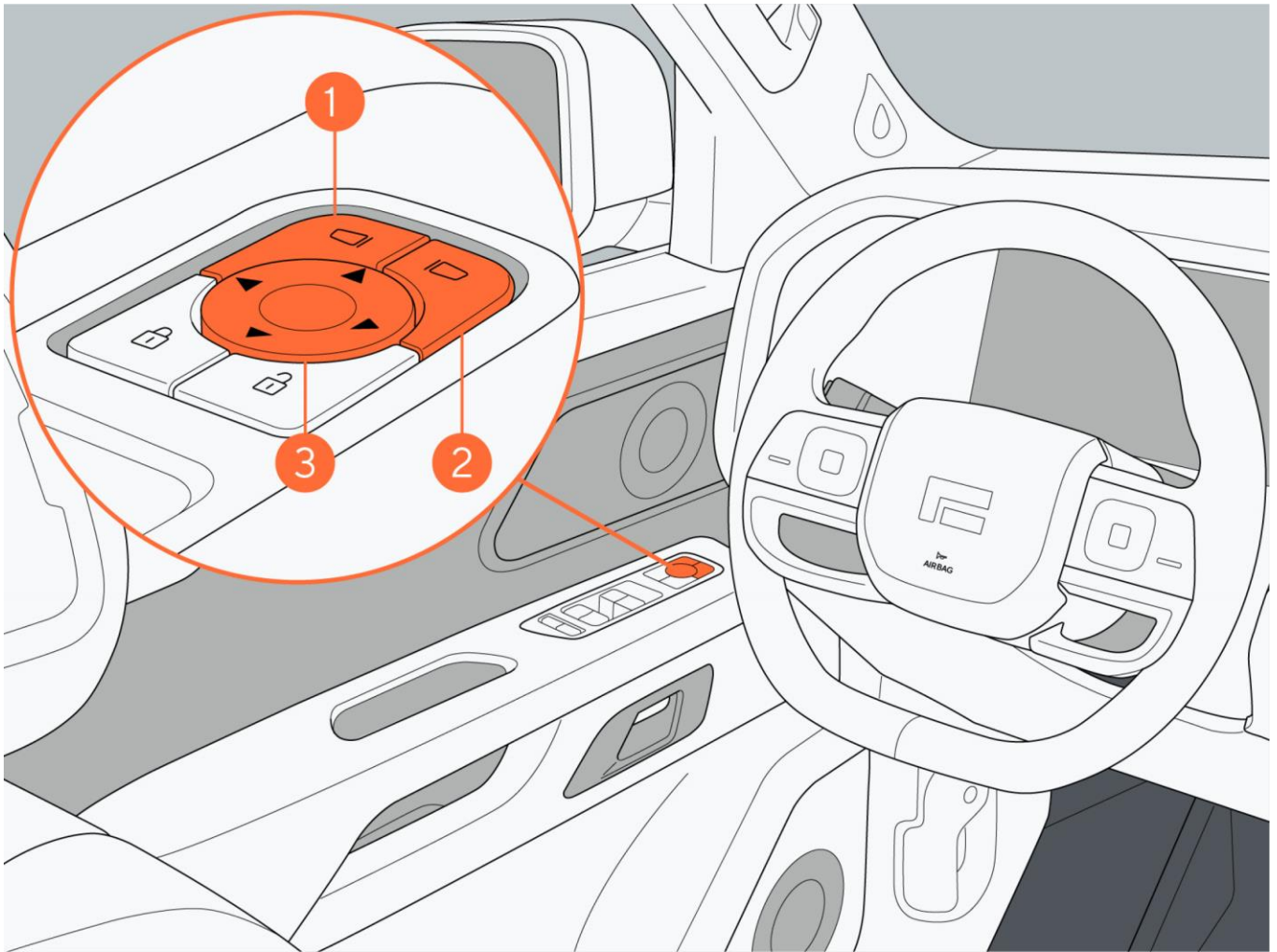



### II. Unfold and fold the exterior rearview mirror

#### 1. Electric folding and unfolding

Electric folding: When the exterior rearview mirror is in an unfolded state, press button 1 and button 2 at the same time to electrically fold the exterior rearview mirror.

Electric unfolding: When the exterior rearview mirror is in a folded state, press button 1 and button 2 at the same time to electrically unfold the exterior rearview mirror.

#### **i** Tip

- When the vehicle speed is greater than 15 km/h, the operation of the electric folding exterior rearview mirror is invalid.
- After the electrically folding the exterior mirror, the electric exterior mirror will remain folded until the vehicle speed is greater than 15 km/h.

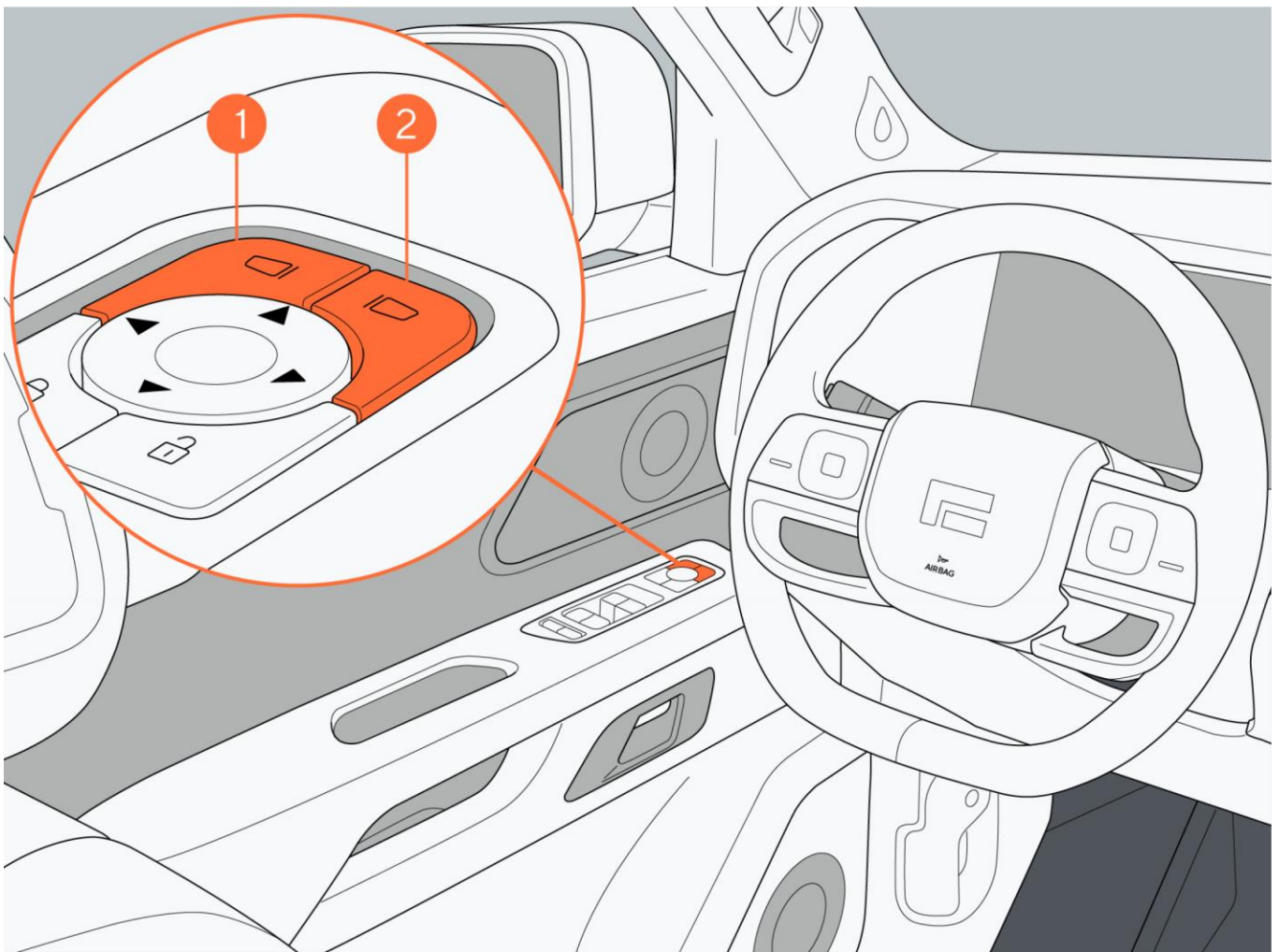

#### 2. Auto folding and unfolding

Auto folding: When the door is locked from outside, the exterior rearview mirror automatically folds.

Auto unfolding: When the door is unlocked from outside, the exterior rearview mirror automatically unfolds.

## 6. Operation

Click " Vehicle Settings → Vehicle → Rearview Mirror → Lock → Auto Fold Rearview Mirror" through the central control screen, to set the activation and deactivation of the auto fold function for the exterior rearview mirror.

### Warning

- Do not touch the exterior rearview mirror during movement to avoid pinching.

### 3. Folding and unfolding through the central control screen

Click "Vehicle Settings → Vehicle → Rearview Mirror → Fold Rearview Mirror" through the central control screen, to set the activation and deactivation of the folding or unfolding for the exterior rearview mirror.

### III. Reversing exterior rearview mirror tilt down

#### 1. Turning on/off reversing exterior rearview mirror tilting down

Click " Vehicle Settings → Vehicle → Rearview Mirror → Auto Tilt Down Mirrors When Reversing" through the central control screen, to set the activation and deactivation of the reversing exterior rearview mirror tilt down function to turn off, only left side, only right side or turn on both sides.

#### 2. Storage of exterior rearview mirror tilt down position

After the function setting is activated, switch to R gear to manually adjust the exterior rearview mirror on the corresponding side. After the adjustment is completed, the system will automatically store this position as the exterior rearview mirror tilt down position.

#### 3. Activating reverse exterior rearview mirror tilt down function

After the function setting is activated, when the vehicle gear is switched to R position, the exterior rearview mirror on the corresponding side will automatically tilt down to the storage position.

### Tip

- During the activation process of the reversing exterior rearview mirror tilt down function, if the vehicle speed is greater than 15 km/h, the vehicle power supply exits the "READY" mode, or when operating the exterior rearview mirror adjustment switch, the reversing exterior rearview mirror tilt down function will automatically exit.

### IV. Heating of external rearview mirror lenses

The exterior rearview lenses come with a heating function. The function is used to heat the left and right exterior rearview lenses to quickly dry water or snow stains in rainy and snowy days.

#### 1. Manual heating

Click the "Rear Defrost" icon through the A/C control interface of the central control screen to manually turn on/off the exterior rearview mirror/rear window heating function.

#### 2. Auto heating

When the heating function of the exterior rearview mirror is turned off, and the wiper gear is switched to low/high speed gear, or the wiper gear is switched to automatic gear for wiping, the heating function of the

rear windows and the exterior rearview mirror are automatically turned on. When the wiper gear is switched to “OFF” position, or the wiper stops wiper with the gear in automatic position, the heating function of the rear window and the exterior rearview mirror is automatically turned off. The current power-on cycle only performs automatic heating once.

### Warning

- Do not touch the exterior rearview mirror lenses during heating to avoid burns.

### Tip

- The heating function of the exterior rearview mirror and rear window will be automatically turned off after 15 min.

#### V. Auto anti-dazzling of exterior rearview mirror

When the vehicle power supply is in the “READY” mode, the mirror surface of the exterior rearview mirror will automatically dim according to the dazzling degree of the rear car lights.

## 6.5 Memory function

### 6.5.1 Driver memory function

The driver can quickly obtain the relevant driver's seat position and exterior rearview mirror position by clicking the “Integrated Control Card → Memory Position” icon on the central control screen. This is convenient for the driver to quickly choose a comfortable driving position.

#### I. Memory position setting

When the user adjusts the position of the driver's seat or the exterior rearview mirror, the central control screen will automatically pop up the memory position setting interface. Click any sitting posture icon on the setting interface to save the mirror position information of the current driver seat and the exterior rearview mirror to the corresponding memory position.

#### II. Memory position call-out

Click the corresponding sitting posture icon through the central control screen to call out the corresponding memory position information.

### Warning

- It is forbidden to call out the memory position during the driving to prevent accidents.

### Tip

- During the memory position call-out process, such as manually adjusting the driver's seat or exterior rearview mirror, the memory position call-out of the corresponding function will be interrupted.

## 6. Operation

### 6.5.2 Driver welcome seat

Click “Vehicle Settings → Vehicle → Seat → Driver welcome seat” through the central control screen, set activation or deactivation of the driver welcome function. It is activated by default.

If the vehicle is in P gear and the seat belt of the driver is untied, when the door on the driver's side is opened, the driver's seat will automatically adjust down to the welcome position for you to get out of the car. When you get in the car and close the door, the driver's seat automatically returns to its original position.

#### Tip

- When the driver welcome seat function is working, if the seat position is manually adjusted, the function will stop working.

## 6.6 Window and sunshade

### 6.6.1 Window

Window switches on the driver's side can control all window lifts. Window switches on the occupant's side can control the corresponding window lifts. If the rear child lock is turned on, the window cannot be lifted through the corresponding window switch in the rear row.

I. Control the window through window switch

Manual lowering: Press the window switch down to stop position 1. Release the window switch when the window is opened to the desired position to stop lowering the window.

Auto lowering: Press the window switch down to stop position 2, and the window will automatically lowered to the lowest position.

Manual lifting: Press the window switch up to stop position 1. Release the window switch when the window is opened to the desired position to stop lifting the window.

Auto lifting: Pull the window switch up to stop position 2, and the window will automatically be lifted to the highest position.

Pause: During the automatic lifting of the window, pull or press the window switch again to stop the current window movement.

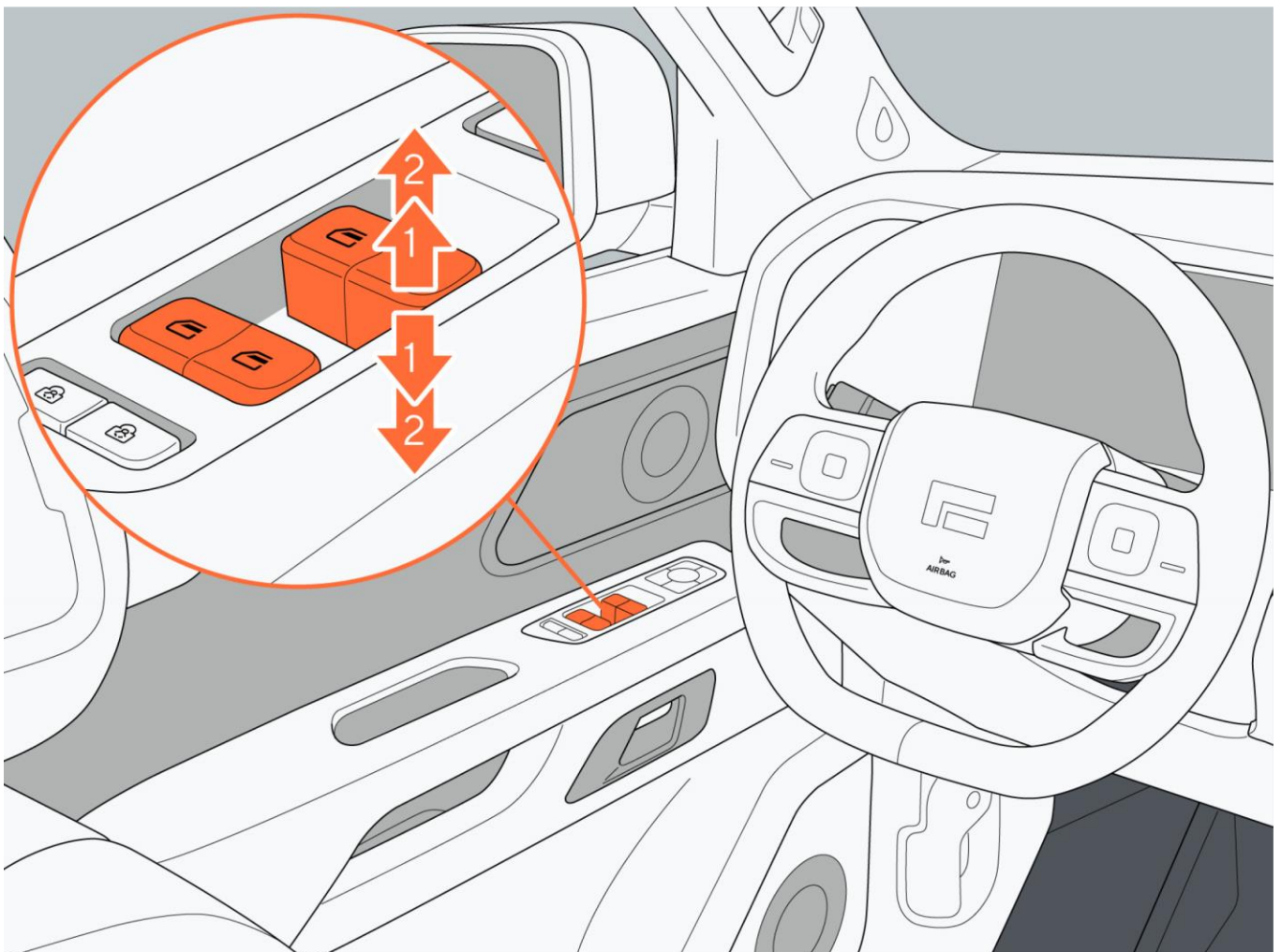

## 6. Operation

### II. Rear-row passenger window locking

Press the child lock button on the left front door to activate the child safety lock, and the corresponding window switch on the rear door cannot control the window. Avoid children or other occupants from mistakenly operating the windows.

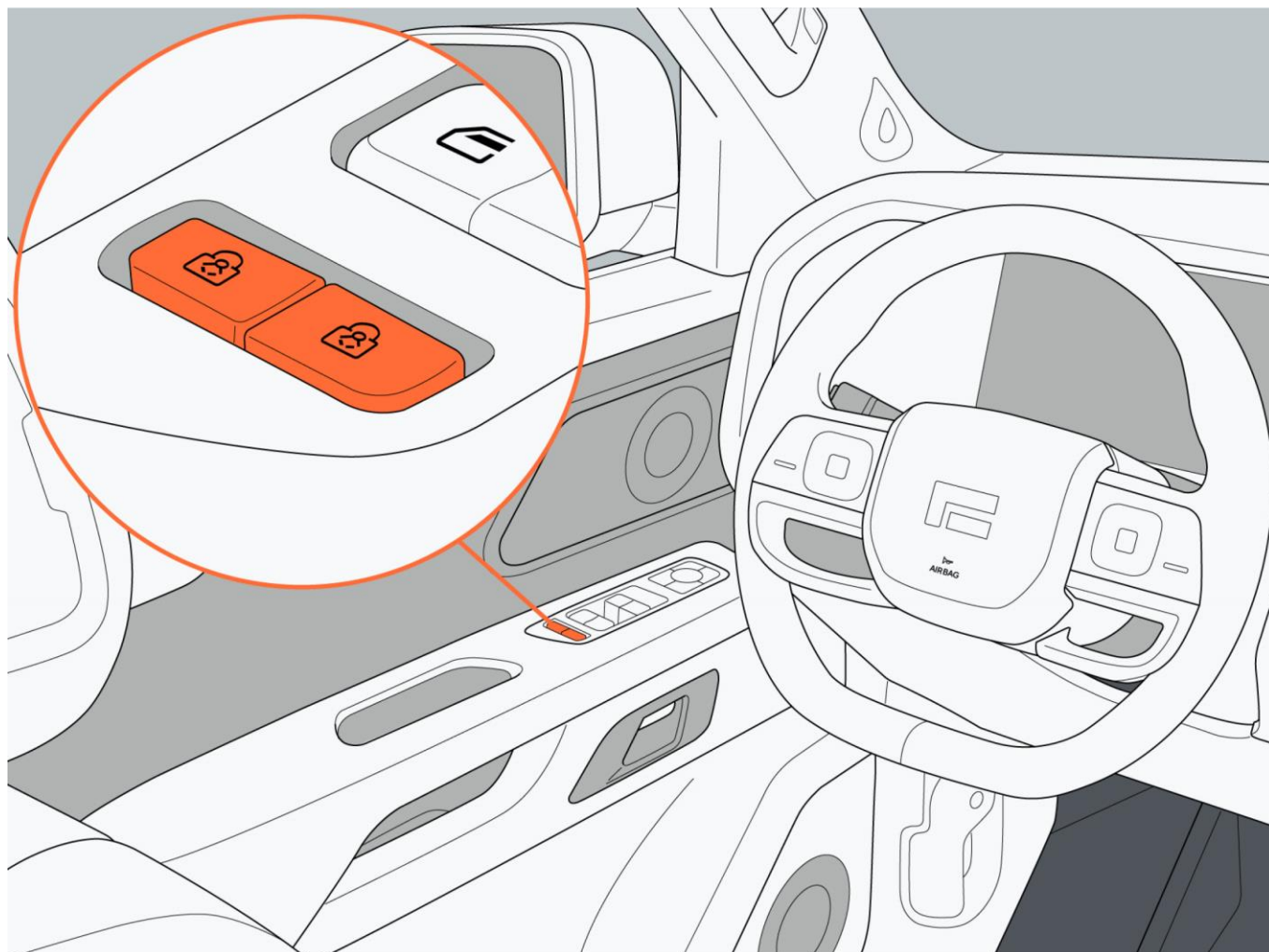



### III. Control the window through the remote Key

Open: When the vehicle power supply is in the " OFF" mode, and all the doors are closed, long press the remote key unlock button 1 within the effective mileage, and the window will automatically open.

Close: When the vehicle power supply is in the " OFF" mode, and all the doors are closed, long press the remote key lock button 2 within the effective mileage, and the windows will automatically close.

Pause: During the automatic opening or closing of the window, press the remote key unlock/lock button again to stop the current movement of the window.

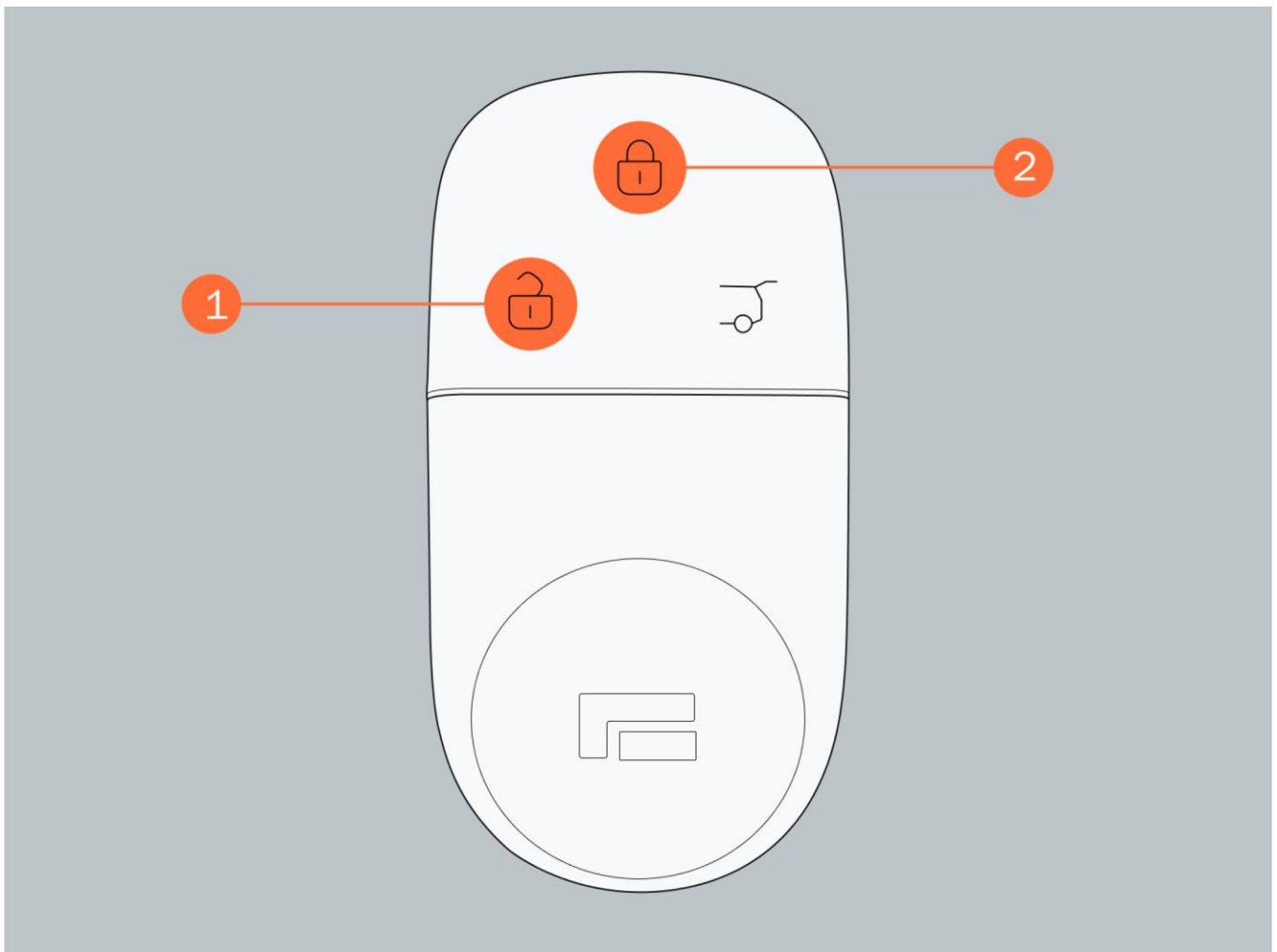

#### Warning

- When closing the window with the remote key, be sure to confirm that there are no obstacles in the movement area of the window before operating to avoid being pinched or damaging the car.

### IV. Automatically close the window in rainy day

With the vehicle in alarm mode, if any window is not closed, when the vehicle senses rain, the window will automatically close.

#### Caution

- This function does not work in all cases (for example, when the sensor fails or the auto window lift function fails, the window will not be closed). Do not rely on this function to close the window to avoid property loss.

## 6. Operation

### V. Automatically close the window by locking the car

If any window is not closed, when the vehicle is locked from outside, the window will be automatically closed. Click " Vehicle Settings → Vehicle → Door Lock → Auto Window Close on Lock" through the central control screen, to set the activation and deactivation of the auto window close on lock function.

#### Warning

- After the auto window close on lock function is activated, do not leave children or pets in the car after locking the car to avoid accidents.
- After the auto window close on lock function is activated, note that there are no obstacles in the movement area of the window when locking the car to avoid unnecessary losses.

### VI. Auto open window due to collision

With all doors closed, when the vehicle is severely collided, the vehicle will automatically unlock and the windows will automatically lower to the lowest position.

### VII. Window anti-pinch

The windows are equipped with an anti-pinch function. When the window encounters obstacles or the window is restricted to move during the closing process, the window will stop moving or reverse moving for a certain distance.

#### Warning

- Do not test the window anti-pinch function with various items to avoid unnecessary losses.
- Although the window has anti-pinch function, it is still necessary to make sure that the closed area of the window is free of obstacles. In special cases (such as thin or soft obstacles), it is impossible to ensure that the window anti-pinch function can be activated.

### VIII. Window initialization

If the auto window lift or anti-pinch function fails, carry out the initialization operation as follows:

1. Pull the window switch up. The window will step up until the window is completely closed.
2. Press the window switch down until the window is fully open. The initialization is completed.

#### Warning

- Before closing the windows, the driver must ensure that all occupants (especially children) do not lean any part of their bodies out of the windows. Otherwise, serious injury may be caused.
- Do not leave children alone in the car. Children may misoperate window switches.
- If the vehicle is unattended, make sure that the vehicle is powered off when leaving the vehicle to ensure that the windows are inoperable.

## 6.6.2 Sunshade

### I. Front sunshade control

1. Sunshade switch control



Open: Short press the back of the front sunshade switch, the front sunshade will stop moving after opening for a short distance. Press the back of the front sunshade switch for a period of time, the front sunshade will automatically move to the fully open position.

Close: Short press the front of the front sunshade switch, the front sunshade will stop moving after closing for a short distance. Press the front sunshade switch for a period of time, the front sunshade will automatically move to the fully closed position.

### **i** Tip

- During the automatic movement of the front sunshade, press the front sunshade switch again, the front sunshade will stop at the current position.

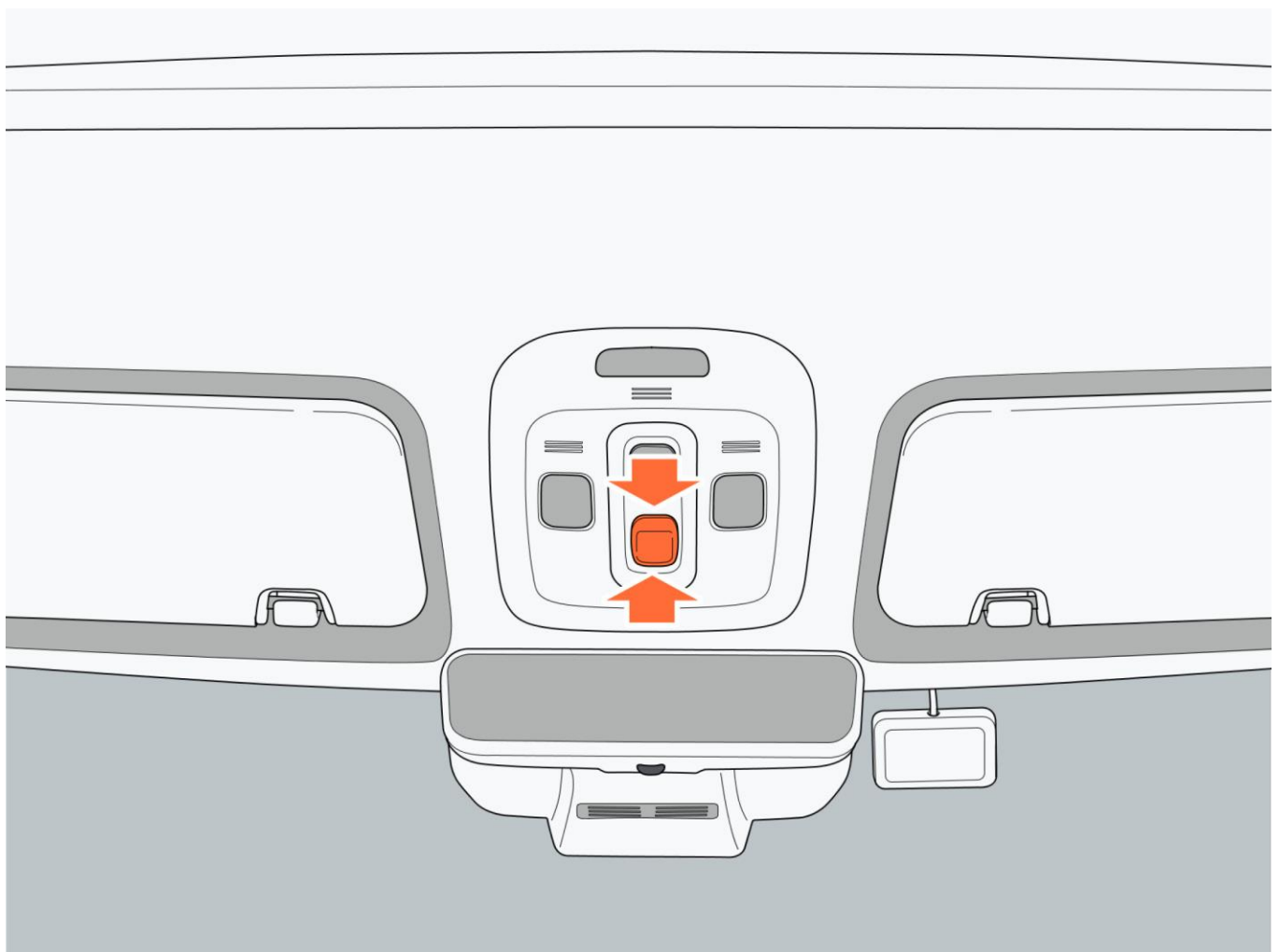

### 2. Remote Key control

When the vehicle power supply is in non "READY" mode, the front sunshade can be opened and closed by the remote key unlocking/locking button. Open: Long press the remote key unlocking button, the front sunshade will automatically move to the fully open position.

Close: Long press the remote key locking button, the front sunshade will automatically move to the fully closed position.

### II. Rear sunshade control

## 6. Operation

### 1. Rear sunshade switch control

Open: Short press the back of the rear sunshade switch, the rear sunshade will stop moving after opening for a short distance. Press and hold the back of the rear sunshade switch for a period of time, the rear sunshade will automatically move to the fully open position.

Close: Short press the front of the rear sunshade switch, the rear sunshade will stop moving after closing for a short distance. Press and hold the rear sunshade switch for a period of time, the rear sunshade will automatically move to the fully closed position.

#### Tip

- During the automatic movement of the rear sunshade, press the rear sunshade switch again, the rear sunshade will stop at the current position.

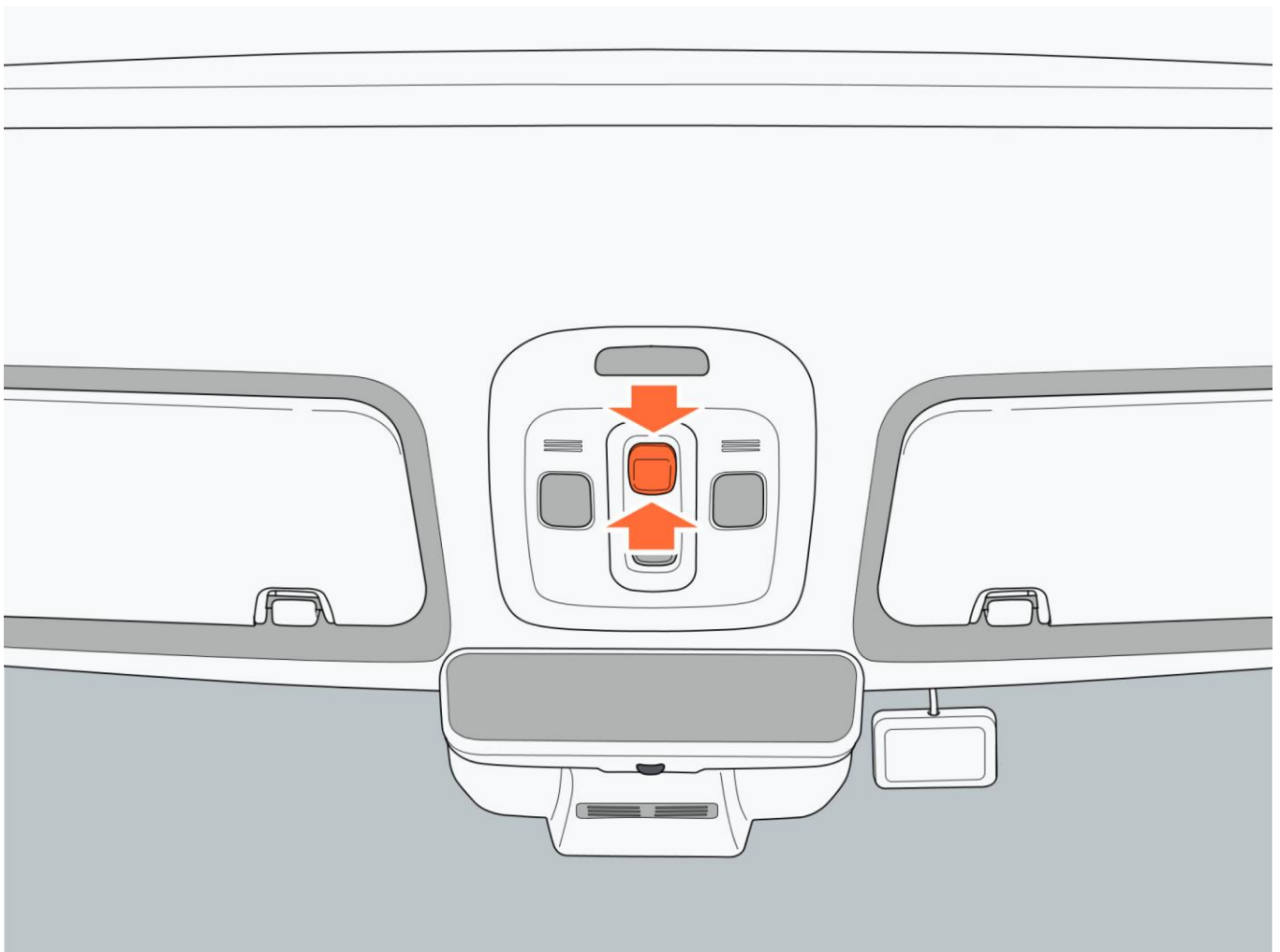

### 2. Remote Key control

When the vehicle power supply is in non “READY” mode, the rear sunshade can be opened and closed by the remote key unlocking/locking button. Open: Long press the remote key unlocking button, the sunshade will automatically move to the fully open position.

Close: Long press the remote key locking button, the sunshade will automatically move to the fully closed position.

### III. Automatically close the sunshade by locking the car

Click “Vehicle Settings → Vehicle → Door Lock → Auto Window Close on Lock” to set the activation and deactivation of the auto window close on lock function. After activation, the front and rear sunshades will automatically close when the vehicle is locked.

### IV. Sunshade anti-pinch

The front/rear sunshades are equipped with an anti-pinch function. When the sunshade encounters obstacles or the sunshade is restricted during the closing process, the sunshade will stop moving or reverse moving for a certain distance.

#### Warning

- Do not test the sunshade anti-pinch function with various items.

### V. Sunshade self-learning

1. Press and hold the sunshade close button until the sunshade is fully closed.
2. After the sunshade is fully closed, press and hold the sunshade close button for more than 10 s.

#### Warning

- When using the remote key to close the sunshade, note that there are no obstacles in the movement area of the sunshade to avoid unnecessary losses.
- After the auto sunshade close on lock is activated, note that there are no obstacles in the movement area of the sunshade when locking the car from outside to avoid unnecessary losses.

#### Caution

- During the initialization operation, keep the sunshade close button pressed all the time. If it is released halfway, the initialization fails, and the above operations need to be carried out again.

## 6. Operation

### 6.7 A/C system

#### 6.7.1 Front A/C system

Front A/C system

Click the A/C icon on the central control screen to open the control A/C interface. Click the bottom of the A/C interface to exit the A/C control interface.



#### I. Front A/C switch

Click the "Switch" icon through the A/C control interface to turn on the front A/C. Click again to turn off the front A/C. When the front A/C is turned off, the front A/C can be turned on by the following operations:

- Adjust the air volume.
- Turn on A/C auto mode.
- Adjust the blowing mode.
- Activate windshield defrost and defog mode.
- Adjust the temperature.

#### II. Temperature setting

In the A/C control interface, slide up/down to set the temperature value. Set the temperature of the main driver and the front passenger respectively. Each slide can increase or decrease the temperature by 0.5°C. Fast slide can quickly adjust the temperature. The set temperature is adjustable within LO (16°C) ~ Hi (32°C).

#### III. Refrigeration mode

Click the "AC" icon through the A/C control interface to turn on the refrigeration mode. Click again to turn off the refrigeration mode.

#### IV. Air speed adjustment

When adjusting the air speed, slide the " Wind Speed" icon left/right through the A/C control interface. Slide left to reduce the air volume, and slide right to increase the air volume. When turned on, the default is the last set value. The maximum air speed can be adjusted to level 9.

### V. Front-row blowing mode

Click the " Blowing Mode" icon on the central control screen. Blowing modes can be combined in different combinations. There are five blowing modes: upper blowing, lower blowing, defrosting, upper and lower blowing and lower blowing and defrosting.

### VI. Front-row temperature synchronization

Click the " Temp Sync" icon through the A/C control interface to turn on the synchronization mode.

When the front-row temperature synchronization is turned on, the temperature of the front passenger's A/C is immediately synchronized with the temperature at the driver. If the temperature is synchronously turned on, when the driver adjusts the A/C temperature, the temperature of the front passenger's A/C changes with the temperature at the driver. When the front passenger adjusts the A/C temperature, the temperature at the driver remains unchanged. At the same time, the temperature synchronization mode is turned off.

### VII. Air circulation

A/C circulation includes three modes: internal circulation, external circulation and auto circulation. The mode is selected or switched through the A/C control interface. When selecting " Auto circulation" , it automatically switches between internal and external circulation modes according to the air quality inside and outside the car to ensure the air quality inside the car.

### VIII. Auto mode

Click the " AUTO" icon through the A/C control interface. After the auto A/C is turned on, the system will automatically adjust the blowing mode and air volume. AC is turned on, and the air circulation mode is switched to auto mode.

### IX. Windshield defrosting and defogging

Click the " Front Defrost" icon through the A/C control interface to turn on the defrosting and defogging functions of the windshield. This can reduce moisture, fog and frost on the surface of the windshield, improve the front vision, and improve driving safety. Click the icon again to turn off the function.

### X. Rear window defrosting and defogging and exterior review mirror heating

Click the " Rear Defrost" icon through the A/C control interface to turn on the defrosting and defogging functions of the rear window and the exterior rearview mirror. This can reduce moisture, fog and frost on the surface of the rear window and the exterior rearview mirror, improve the rear vision, and improve driving safety. Click the icon again to turn off the function.

### XI. Air purification

The A/C activated carbon filter element has the function of purifying the air. The vehicle displays the current PM2.5 air quality in the vehicle through the A/C control interface. The air quality level value displays different colors according to the air quality level.

### XII. Front-row swing mode

## 6. Operation

Set the swing mode of electric air outlet on the side of the driver and front passenger cab through the A/C control interface. There are four modes: manual mode, direct blow, indirect blow and auto sweep. The default blowing angle is fixed. Double click an air outlet to close or open it. There are left and right air outlets on the driver's side. After changing the swing mode, the left/right sides change at the same time.

XIII. Bottom function bar of the central control screen

Through the function bar at the bottom of the central control screen, click "Temp" and "Temp Left/Right Arrow" or slide the "Temp" area through the central control screen bottom function bar to pop up the temperature control slider. Click other areas to put away the temperature control interface.

### 1. Temperature setting

Click the left/right arrow of the "Temp" icon in the bottom function bar of the central control screen to set the A/C temperature in the car. Each click can increase or decrease the temperature by 0.5°C. Click the left/right arrow of the "Temp" icon or slide the temperature slider left and right to quickly adjust the temperature.

### 2. Temperature synchronization

When the front-row temperature synchronization is turned on, the temperature of the front passenger's A/C is immediately synchronized with the temperature at the driver. If the temperature is synchronously turned on, when the driver adjusts the A/C temperature, the temperature of the front passenger's A/C changes with the temperature at the driver. When the front passenger adjusts the A/C temperature, the temperature at the driver remains unchanged. At the same time, the temperature synchronization mode is turned off.

### 3. Air speed adjustment

Click the " Air Speed" icon and slide left and right to quickly adjust the air speed. When the air speed gear is 1, slide left to turn off the A/C system. When the A/C system is off, slide right to turn on the A/C system.

### XIV. A/C air outlet position

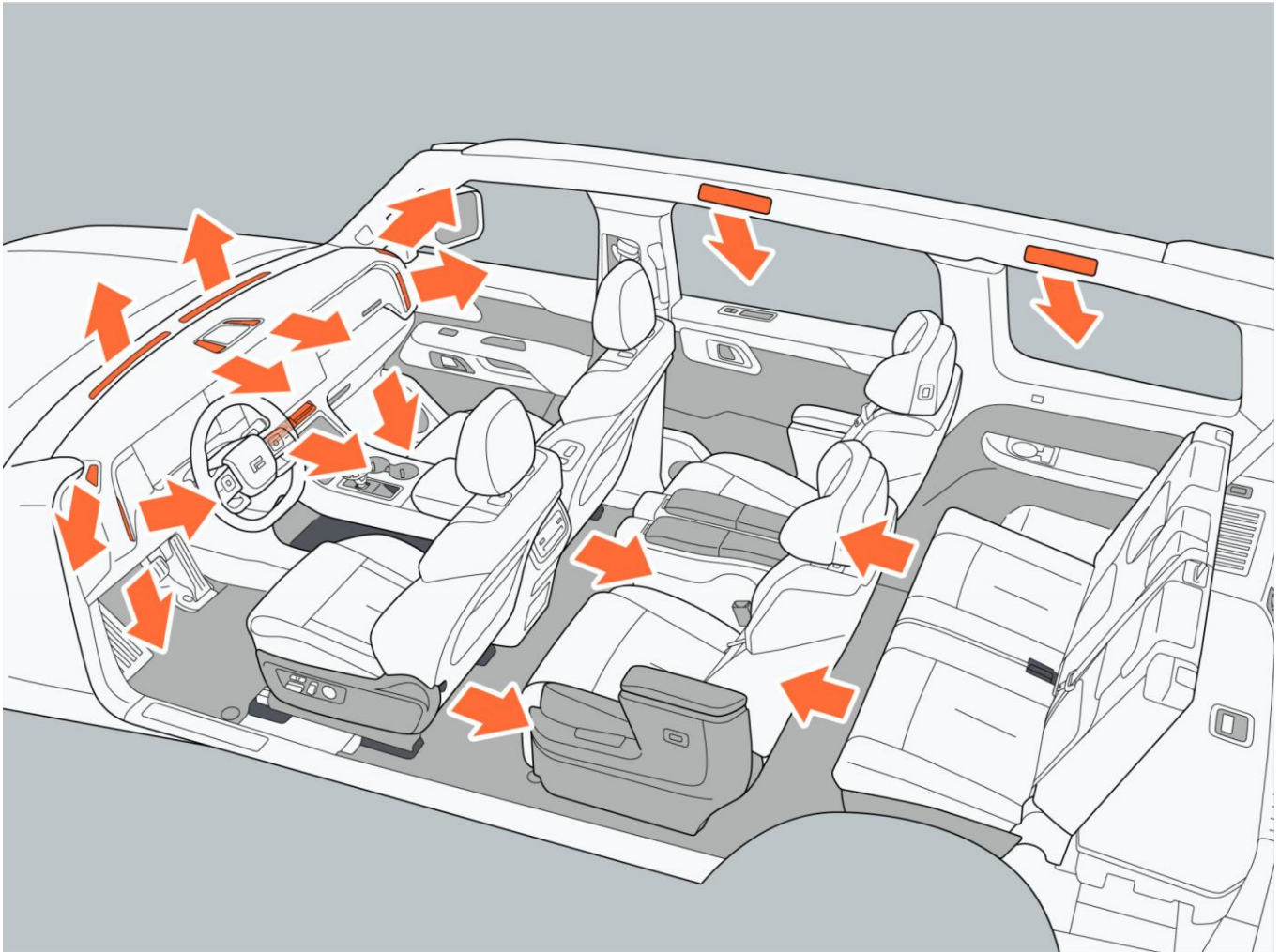

#### Warning

- While resting in the car for a long period of time, avoid difficulty breathing or suffocation caused by closed windows or poor ventilation.
- Do not place any items on the instrument panel. Avoid blocking the air outlet to affect the glass defogging.
- Do not touch the rearview mirror during heating to avoid burns.

#### Caution

- Check the A/C system in a regular way to keep the A/C system in optimal working condition.
- When using the internal circulation, the recommended use time is within 30 min.
- Clean the A/C condenser with a low-pressure water gun in a regular way to prevent leaves and

## 6. Operation

insects accumulating on its surface from hindering the airflow, resulting in the reduction of the refrigeration effect.

### 6.7.2 Rear A/C system

I. Control through the front central control screen

Click the A/C icon on the central control screen to open the control A/C Control interface. Click the “Switch to Rear Row” icon to switch to the rear A/C control interface.



II. Rear A/C switch

Click the “Switch” icon through the A/C control interface to turn on the rear A/C. Click again to turn off the rear A/C. When turning off the rear A/C, the rear A/C can be turned by the following operations:

- Turn on rear A/C auto mode.
- Set rear A/C air speed.
- Set rear A/C blowing mode.

III. Temperature setting

Set the temperature of the rear A/C by sliding up/down through the A/C control interface. Each slide can increase or decrease the temperature by 0.5°C. Fast slide can quickly adjust the temperature. The set temperature is adjustable within LO (16°C) ~ Hi (32°C).

IV. Air speed adjustment

Click the “Air Speed” icon on the A/C control interface to set the air speed gear. For each click, the air speed gear will change to a gear. Slide left/right to quickly adjust the air speed.

V. Rear-row blowing mode



Click one of the "Blowing mode" icons through the A/C control interface to select two blowing modes: upper and lower.

### VI. Auto mode

Click the "AUTO" icon through the A/C control interface. After the auto A/C is turned on, the system will automatically adjust the blowing temperature, blowing mode and air volume.

### VII. Rear A/C lock

This function is off by default. The A/C lock function can be turned on by clicking the "A/C Lock" icon on the control interface of the front A/C system. When the function is turned on, the rear A/C control panel is unavailable.

### VIII. Rear-row intelligent A/C (subject to the real car)

This function is off by default. Click "Rear Intelligent A/C" through the A/C interface to turn on or off the rear intelligent A/C function.

After the rear intelligent A/C is turned on, if the vehicle detects that the rear passengers get off for more than 3 min, the rear A/C will automatically turn off. After the rear passengers get on for exceeding 10 s, the rear A/C will automatically turn on. The A/C state is the state when it was last turned off.

#### Tip

- During the memory position call-out process, such as manually adjusting the driver's seat or exterior rearview mirror, the memory position call-out of the corresponding function will be interrupted.

When the remote A/C is turned on, the automatic shutdown function of the rear A/C is not available.

### IX. Rear A/C control panel control

S/N	Name	S/N	Name
1	Temperature setting	5	Blowing mode
2	Air speed setting	6	Right seat heating
3	Automatic mode	7	Rear A/C switch
4	Left seat heating		

## 6. Operation

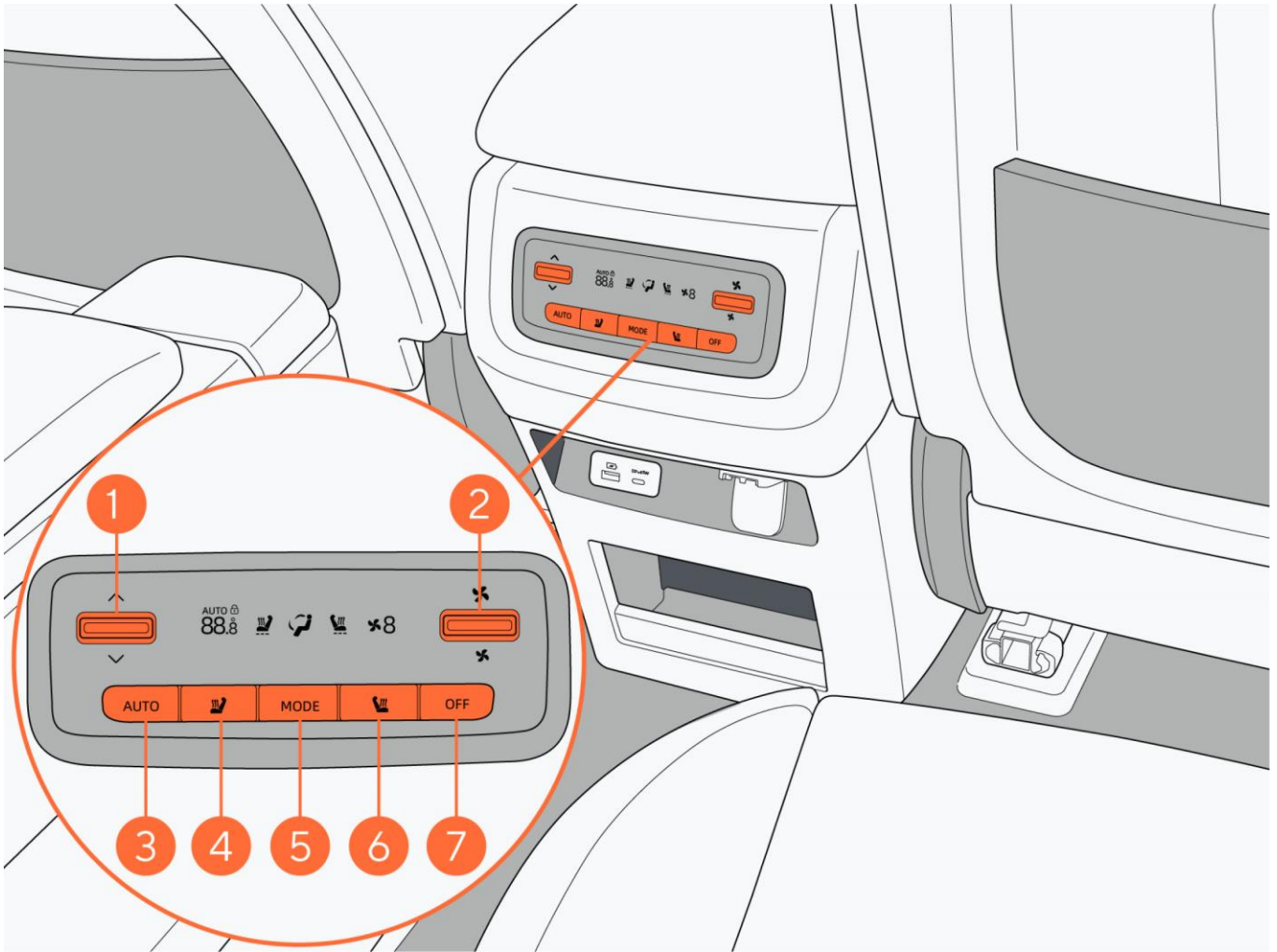

### 1. Temperature setting

Short press the left temperature adjustment button up/down to set the rear temperature. Each short press can increase or decrease the temperature by 0.5°C. Long press the temperature adjustment button up/down to quickly adjust the temperature.

### 2. Air speed setting

Short press the right air speed adjustment button up/down to set the air speed gear. Each press can change the air speed gear to another position. Long press the air speed adjustment button up/down to quickly adjust the air speed gear.

### 3. Automatic mode

Click the " AUTO " button on the rear A/C control interface to change the rear A/C into the auto mode. The system will automatically adjust the blowing temperature, blowing mode and air speed.

### 4. Left seat heating

Activation: Press the " Seat Heating " button on the rear A/C control interface to select the seat heating gear for the left seat in the second row.

Deactivation: With the seat heated, click the " Seat Heating " button until it is turned off.

The seat heating function consists of three gears: 3, 2 and 1. Gear 3 has the highest temperature, and gear 1 has the lowest temperature.

### 5. MODE

Press the "MODE" blowing mode switch button to switch three blowing modes: upper, lower, and upper and lower.

### 6. Right seat heating

Activation: Press the "Seat Heating" button on the rear A/C control interface to select the seat heating gear for the right seat in the second row.

Deactivation: With the seat heated, click the "Seat Heating" button until it is turned off.

The seat heating function consists of three gears: 3, 2 and 1. Gear 3 has the highest temperature, and gear 1 has the lowest temperature.

### 7. Rear A/C switch

Press the rear A/C "OFF" button to turn on/off the rear A/C.

When the rear A/C is turned off, it can be turned on by the following operations:

- Short or long press the temperature adjustment button up/down.
- Press the auto mode button.
- Short or long press the air speed adjustment button up/down.
- Press the blowing mode switch button.

### X. Air outlet position

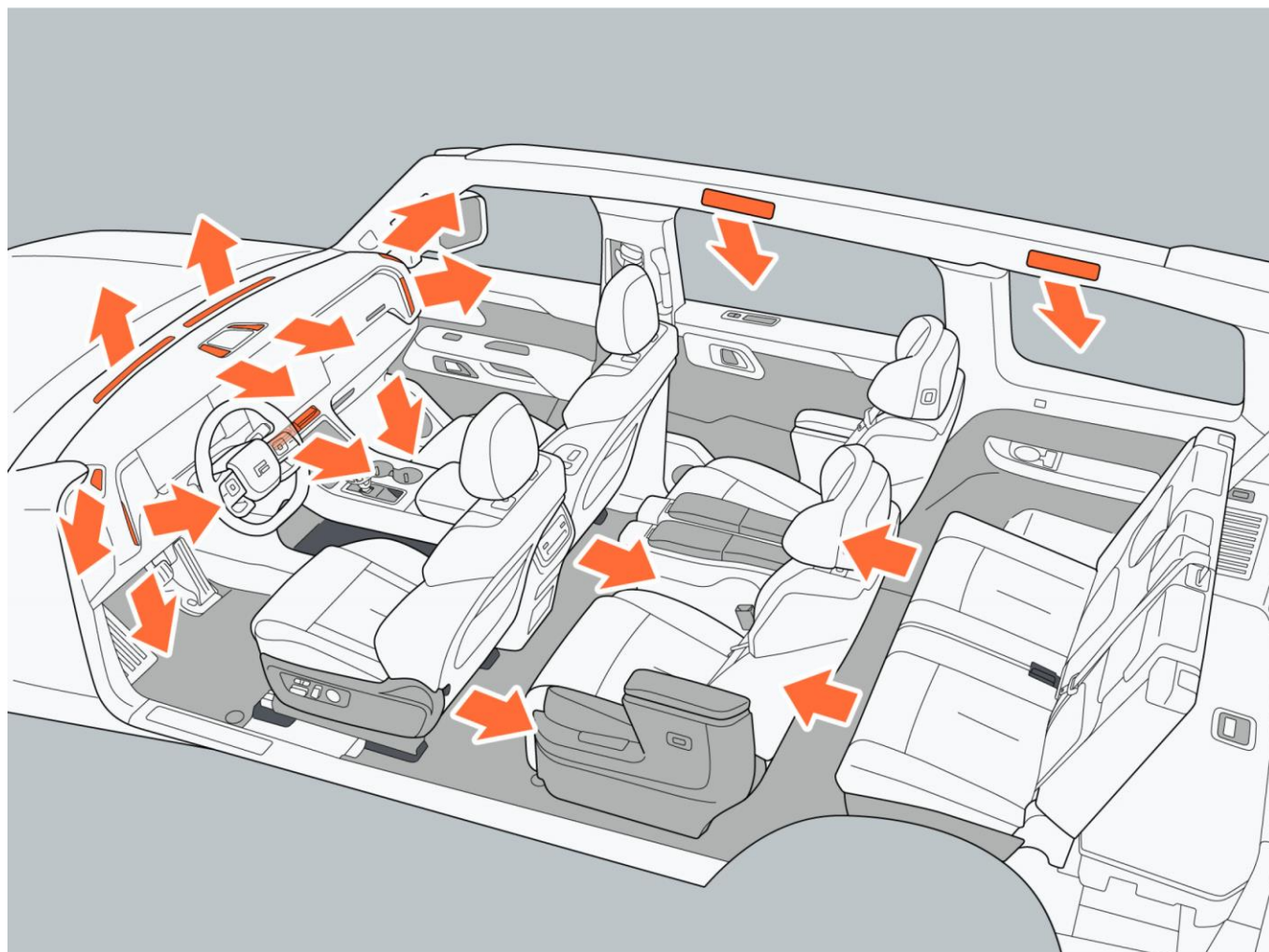

## 6. Operation

### XI. Ceiling air outlet

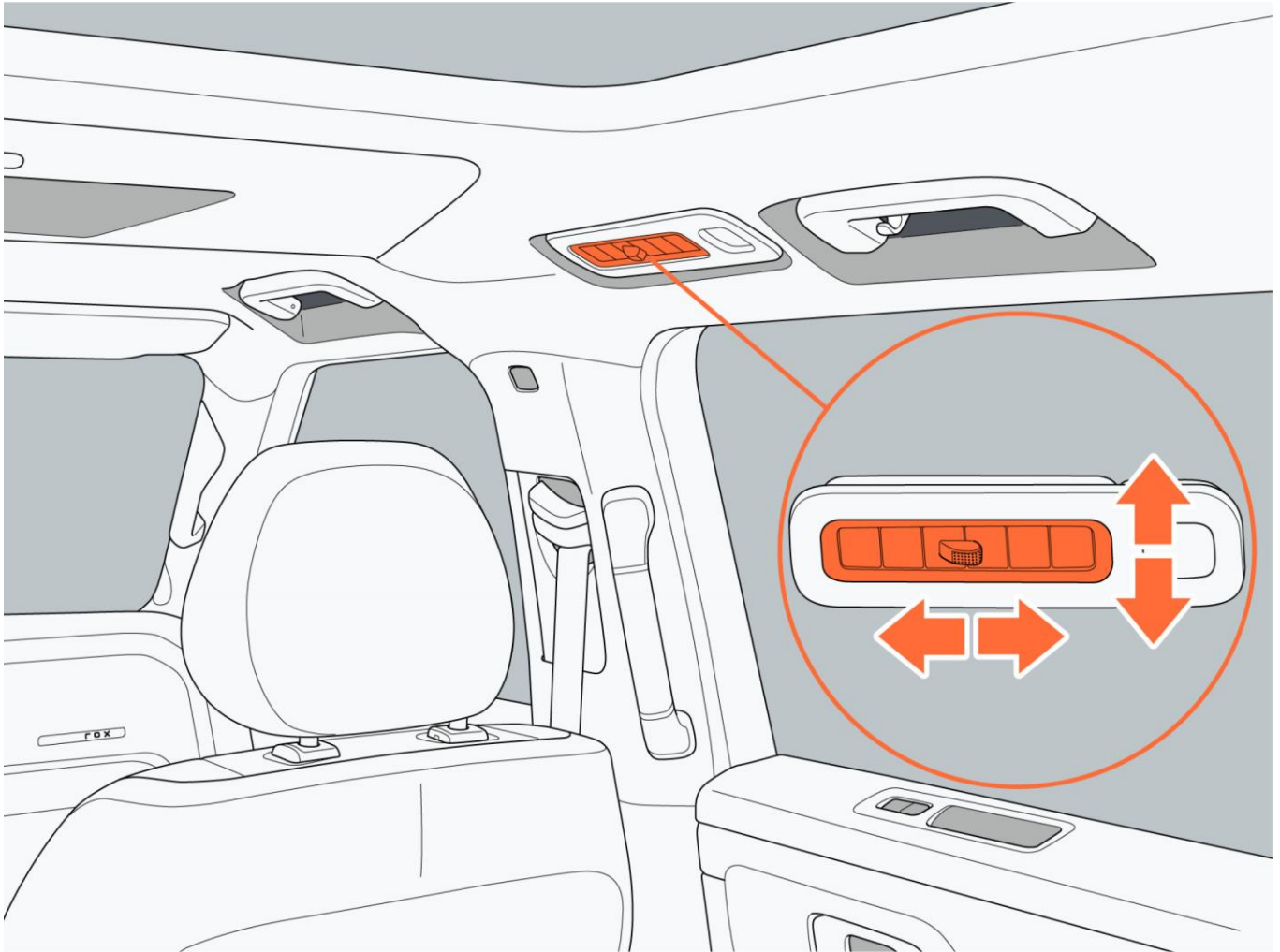

### 6.7.3 Steering wheel heating/seat heating and ventilation

#### I. Steering wheel heating

Click the "Steering Wheel Heating" icon on the "A/C Control" interface of the central control screen to turn on the steering wheel heating function. Click again to turn off the steering wheel heating function.

#### II. Front seat heating/seat ventilation

Click "Seat" icon on the A/C control interface to enter the front-row seat operation interface.

Activation: Click the "Seat Heating" and "Seat Ventilation" icons of the front-row seat on the A/C system control interface to select the heating and ventilation gears for the driver's seat and the front passenger's seat respectively.

Deactivation: With the seat heated or ventilated, click the "Seat Heating" or "Seat Ventilation" icons until it is turned off. The seat heating function consists of three gears: 3, 2 and 1. Gear 3 has the highest temperature, and gear 1 has the lowest temperature.

The seat ventilation function consists of three gears: 3, 2 and 1. Gear 3 has the highest air force, and gear 1 has the lowest air force.

#### III. Second-row seat heating (common seat)

Turn on/off the seat heating through the rear A/C control panel.

Activation: Press the "Seat Heating" button on the rear A/C control interface to select the seat heating gear for the left/ right seat in the second row respectively. Deactivation: With the seat heated, click the "Seat Heating" button until it is turned off.

The seat heating function consists of three gears: 3, 2 and 1. Gear 3 has the highest temperature, and gear 1 has the lowest temperature.

#### IV. Second-row seat heating/seat ventilation (aviation seat)

Click "Seat → Switch to Second Row" through the A/C control interface to enter the rear seat operation interface or turn on/off seat heating through the rear A/C control panel.

Activation: Click the "Seat Heating" and "Seat Ventilation" icons of the second-row seat on the A/C system control interface to select the heating and ventilation gears for the left/right seats of the second row respectively.

Deactivation: With the seat heated or ventilated, click the "Seat Heating" or "Seat Ventilation" icons until it is turned off.

The seat heating function consists of three gears: 3, 2 and 1. Gear 3 has the highest temperature, and gear 1 has the lowest temperature.

The seat ventilation function consists of three gears: 3, 2 and 1. Gear 3 has the highest air force, and gear 1 has the lowest air force.

#### Tip

- Seat ventilation and seat heating functions cannot be turned on at the same time.



#### V. Second-row seat heating/seat ventilation (aviation seat)



## 6. Operation

The seat heating/seat ventilation button is located under the armrest cover of the seat. Open the armrest cover and you may see it.

Activation: Short press the " Seat Heating/Ventilation" button on the control panel to cycle through the seat heating/ventilation gear.

Deactivation: With the seat heated or ventilated, press the " Seat Heating" or " Seat Ventilation" buttons until it is turned off.

### Tip

- Seat ventilation and seat heating functions cannot be turned on at the same time.

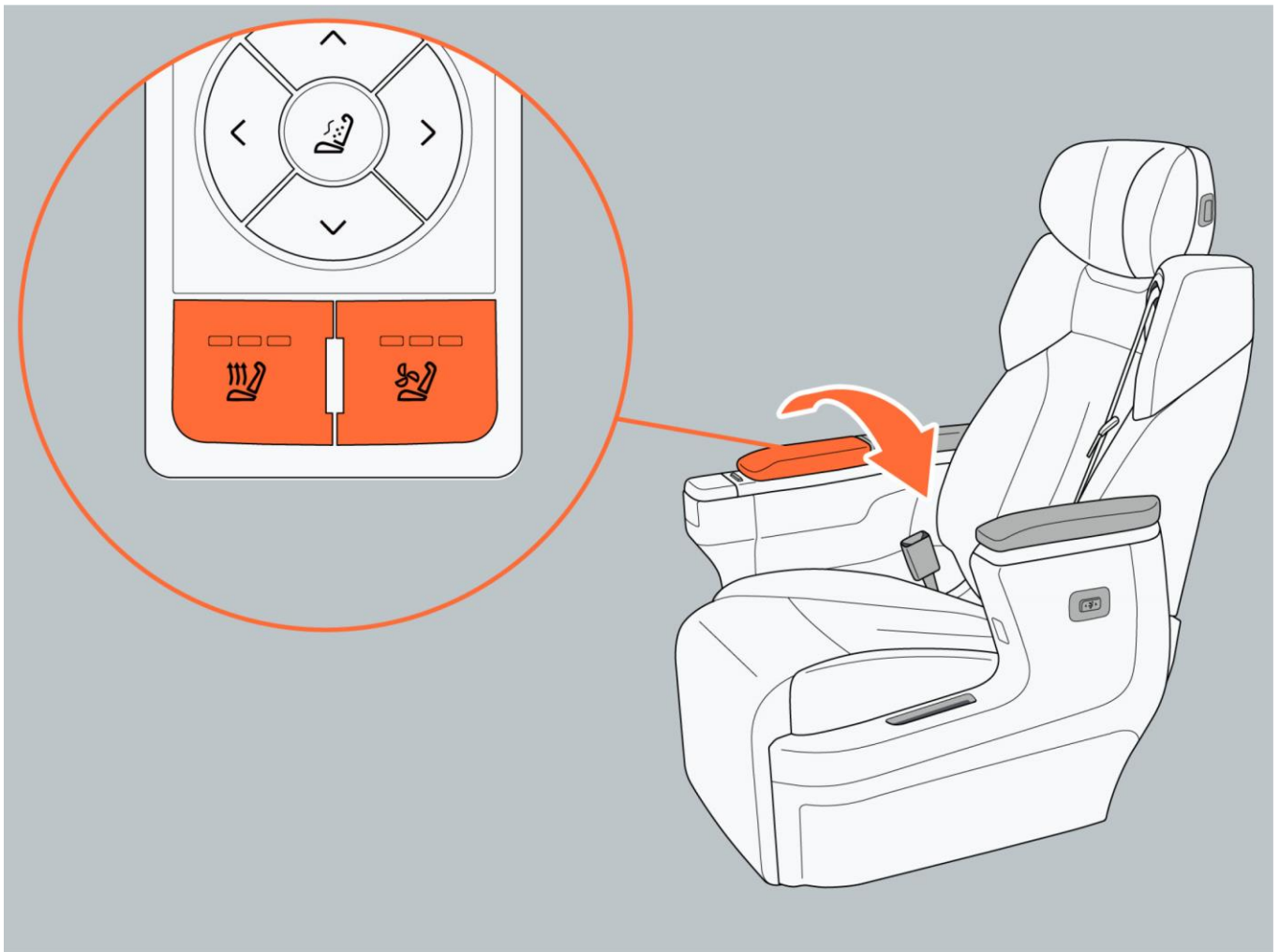

### Warning

- Children, the elderly, the sick, the disabled and people with limited pain perception should be particularly careful when using heating function.
- When using seat heating, do not cover the seat with blanket or cushion, etc., to avoid damage or burns.
- Do not place sharp objects on the seat to avoid damaging the heating/ventilation device.

- Turn off the heater when there is no occupant to avoid damage.

### 6.8 Vehicle interior illumination light

#### 6.8.1 Interior reading light control

##### I. Control of central control screen

The reading light switch on the central control screen has three gears: always on, always off, and auto. Click "Vehicle Settings → Vehicle → Light → Reading Light" through the central control screen to control the reading light:

- Fully open: Turn on all reading lights in the car.
- Fully closed: Turn off all reading lights in the car.
- Auto: Turn on the reading light auto mode.

## 6. Operation

### II. Control of interior reading light switch

You can separately control the on and off of each reading light with the interior reading light switch. Touch the reading light switch once to turn on the reading light on. Touch it again to turn it off.

#### **i** Tip

- The operation method of the reading lights in the second row and the third row is the same as that of in the front row.

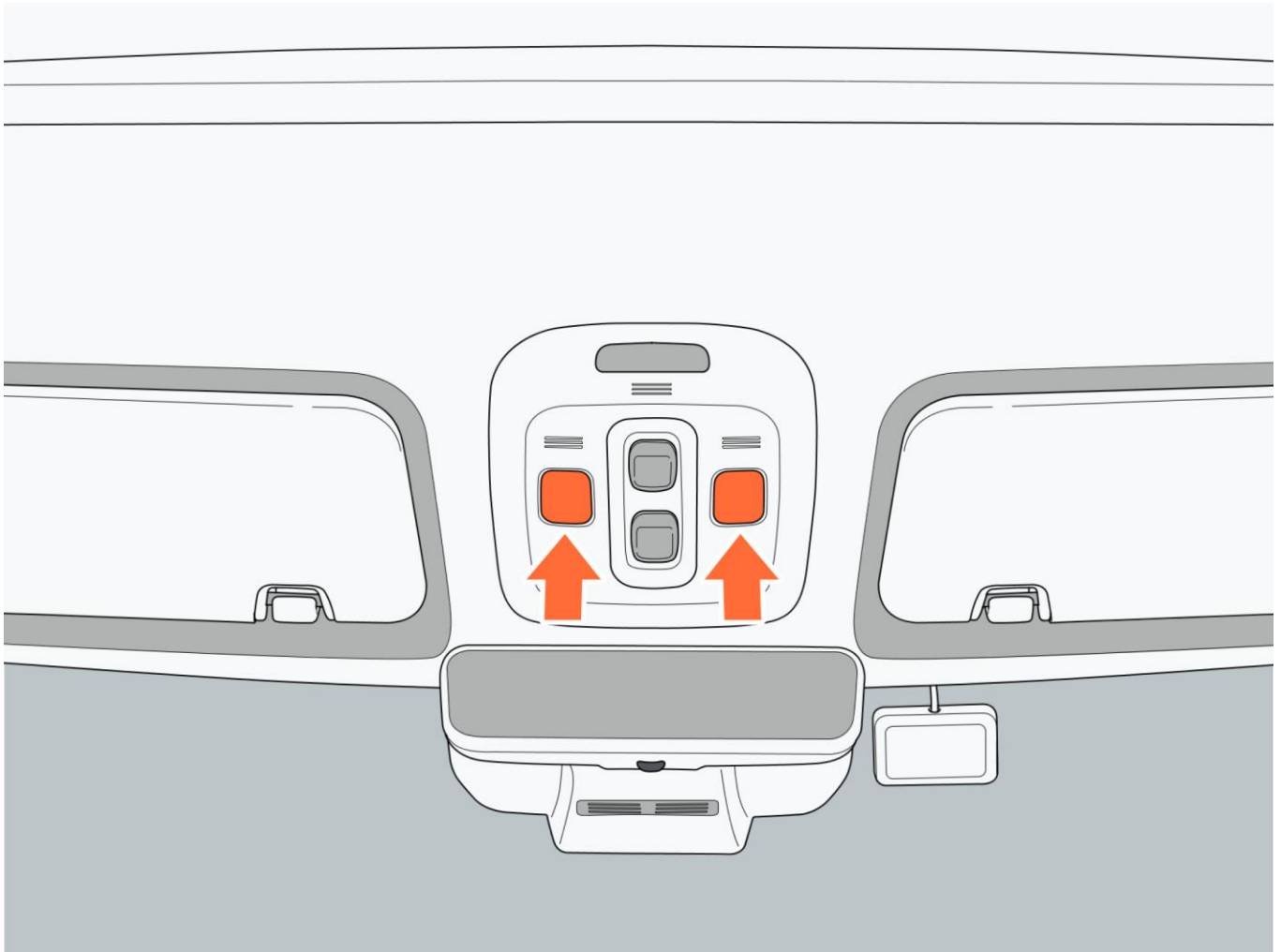

### III. Reading light auto mode

After the reading light auto mode is turned on, when opening any door (excluding the trunk door), the reading light will automatically turn on. After the reading light automatically illuminates, it will automatically go out if:

- The vehicle is locked from outside.
- The vehicle power supply is switched from " OFF" mode to " ON" or " READY" mode.
- All doors are closed.

#### **i** Tip



- When the vehicle power supply is in “OFF” mode, after closing all the doors, the reading light will go out after a delay of 30 s.

### 6.8.2 Vanity lamp

When opening the vanity mirror cover, the vanity light will illuminate; When closing the vanity mirror cover, the vanity light will go out.

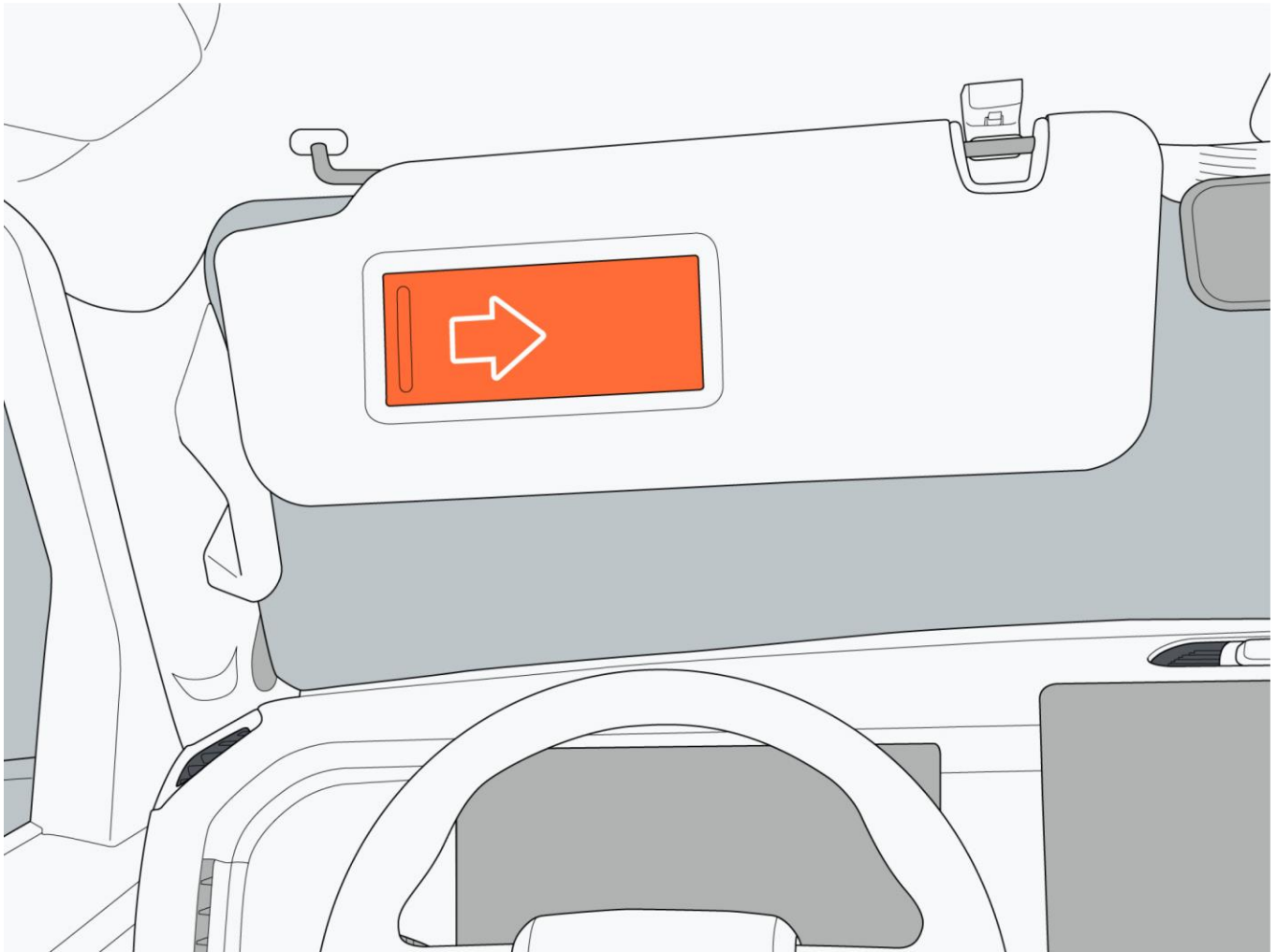

### 6.8.3 Ambient light

The vehicle provides ambient light in the car. You can set the ambient light effect according to your personal preferences. This will bring a pleasant driving experience for you. Click “Vehicle Settings → Vehicle → Ambient Light” through the central control screen to enter the ambient light control interface.

#### I. Activate/deactivate

Click the options under the ambient light to set the ambient light on and off:

- Turn off: Turn off the ambient light.
- Always on: Turn on the ambient light to keep it always on.
- Breathing: Turn on the ambient light to keep it in a breathe state.

#### II. Brightness of ambient light

## 6. Operation

Slide the slider on the right side of “Ambient Light Brightness” to adjust the brightness.

### **i** Tip

- When the ambient light mode is “Breathe”, the brightness cannot be adjusted.

### III. Ambient light mode

Click the option under the ambient light mode to adjust the ambient light mode. There are two modes in the ambient light mode: always on and breathe. The default is always on.

### IV. Ambient light color

After the ambient light is turned on, click the corresponding color icon to set the ambient light color.

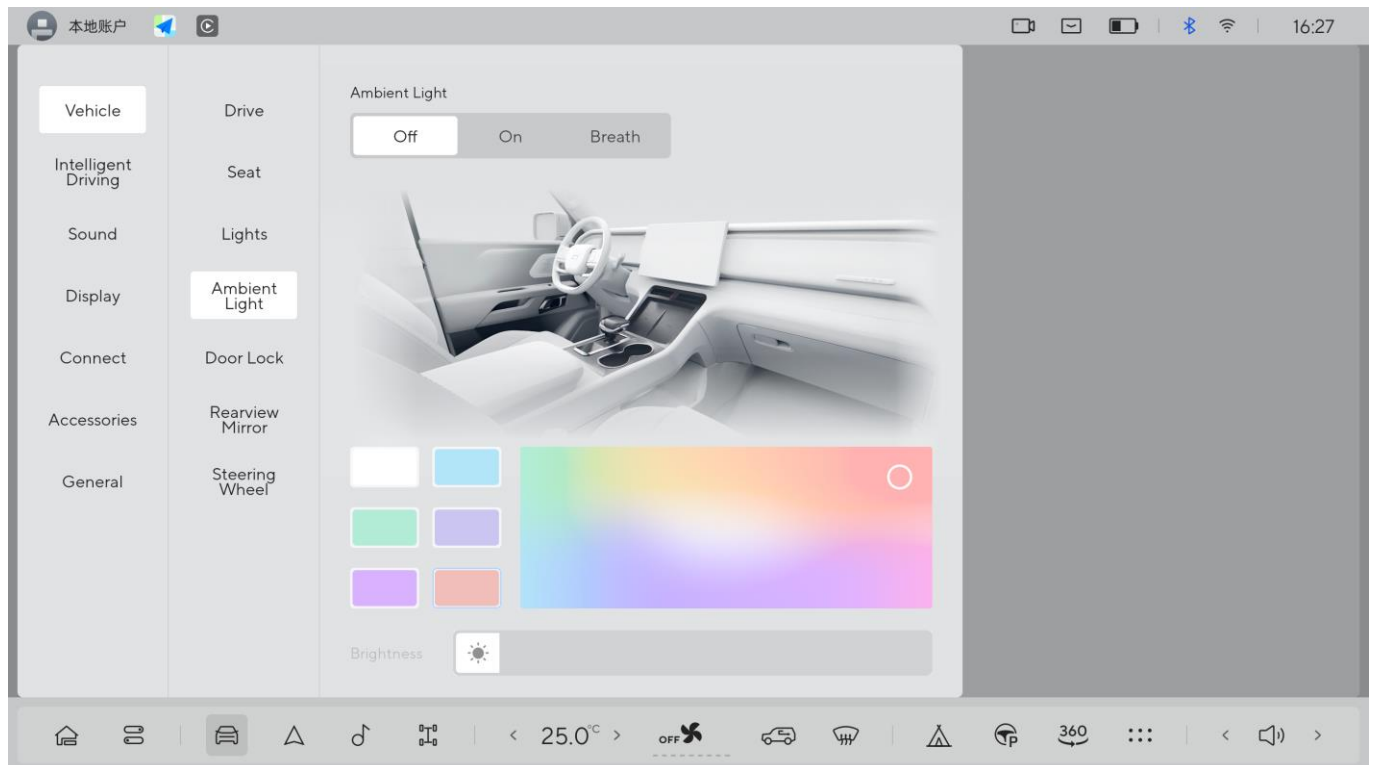

### 6.8.4 Welcome light illumination

When you carry the remote key or Bluetooth key close to/away from the vehicle, the door handle welcome light will automatically light on/off. To enable/disable the welcome function, click “Vehicle Settings → Vehicle → Light → Approach Welcome” through the central control screen for setting.

## 6.9 Storage device

### 6.9.1 Glove box

I. Open the glove box

Open: Pull the glove box switch to open the glove box.

Close: Push the glove box directly to the closed position until you hear a click sound.

II. Glove box light

When the glove box is opened, the glove box light automatically illuminates.

#### Warning

- To avoid damaging the glove box, do not use too much force when pulling the glove box.
- During driving, the glove box must be closed to avoid the items in the glove box flying out and injuring the occupants when the vehicle is braking urgently or in an accident.

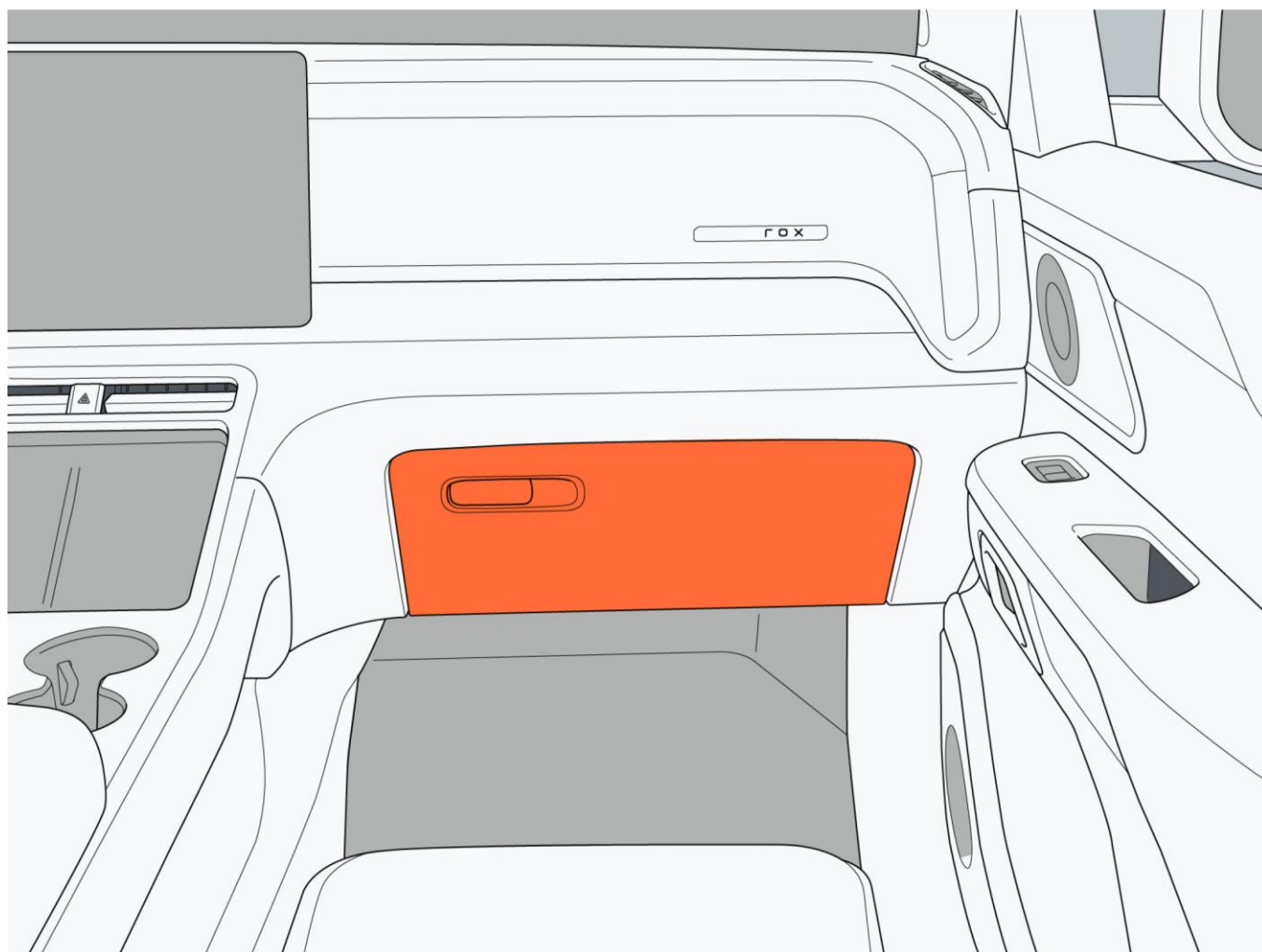

## 6. Operation

### 6.9.2 Storage box

#### I. Armrest box

Lift up the armrest box cover to place tissue paper and other items.

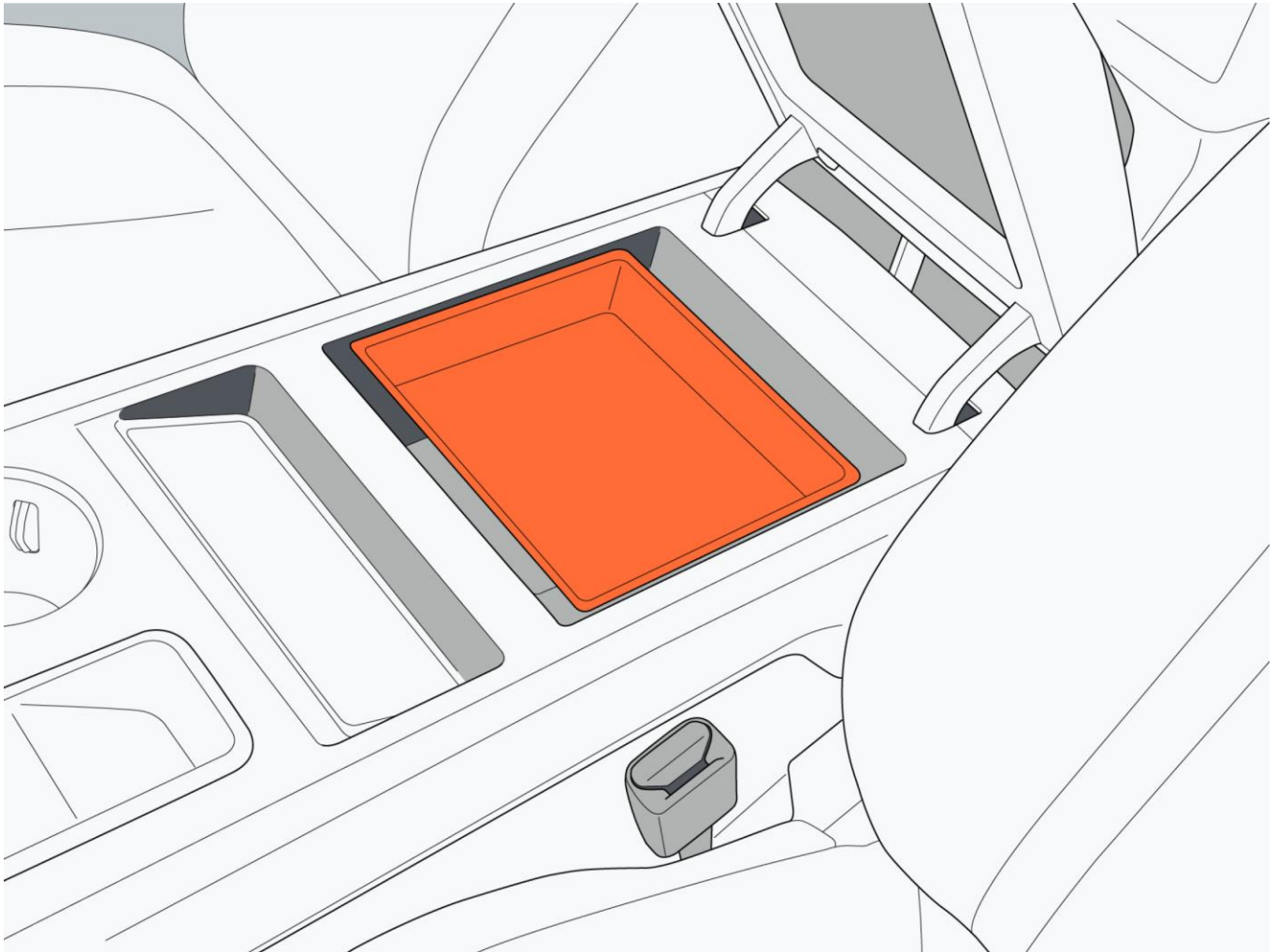

II. Central console lower storage box

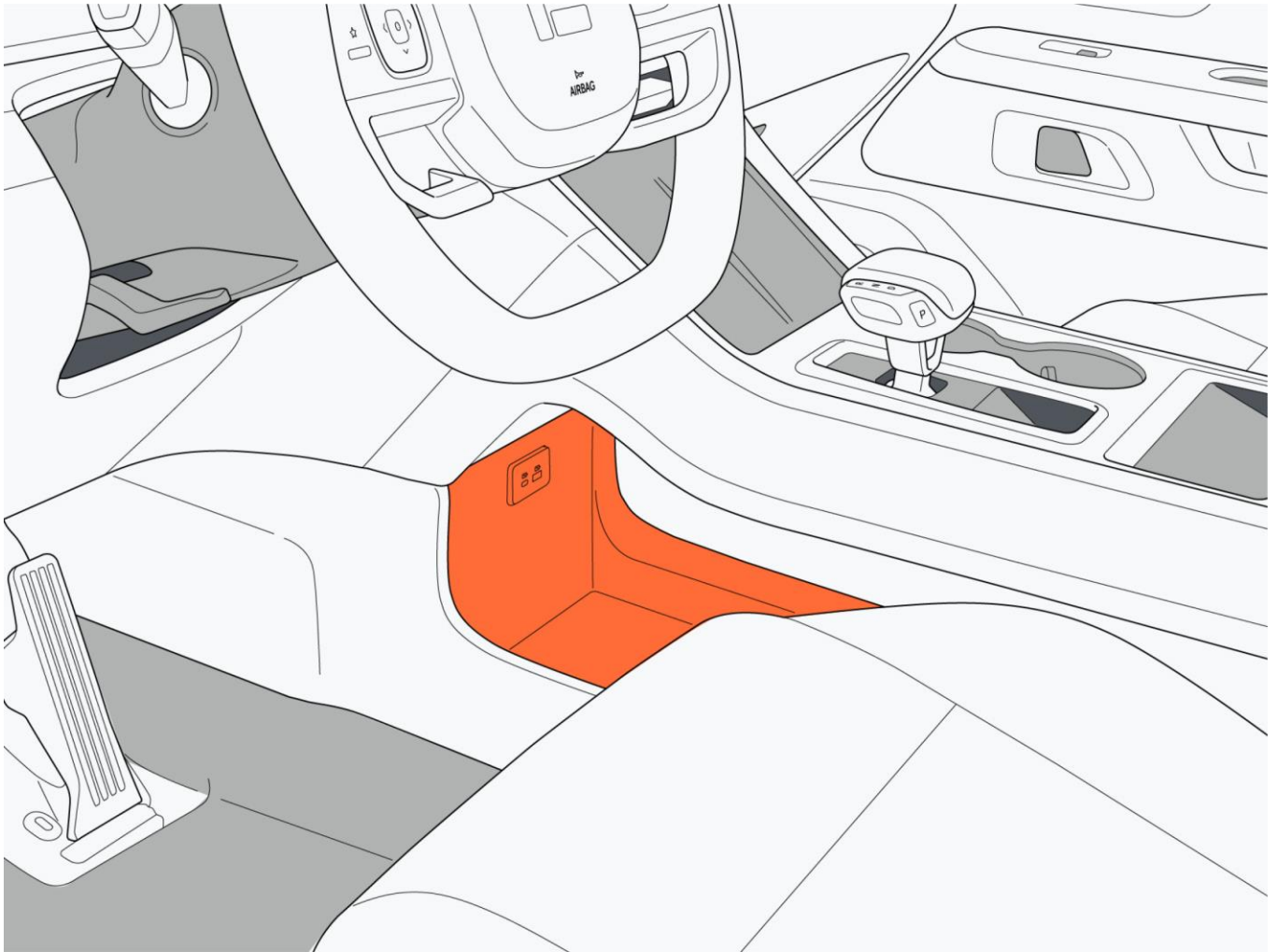

## 6. Operation

### III. Central console rear storage box

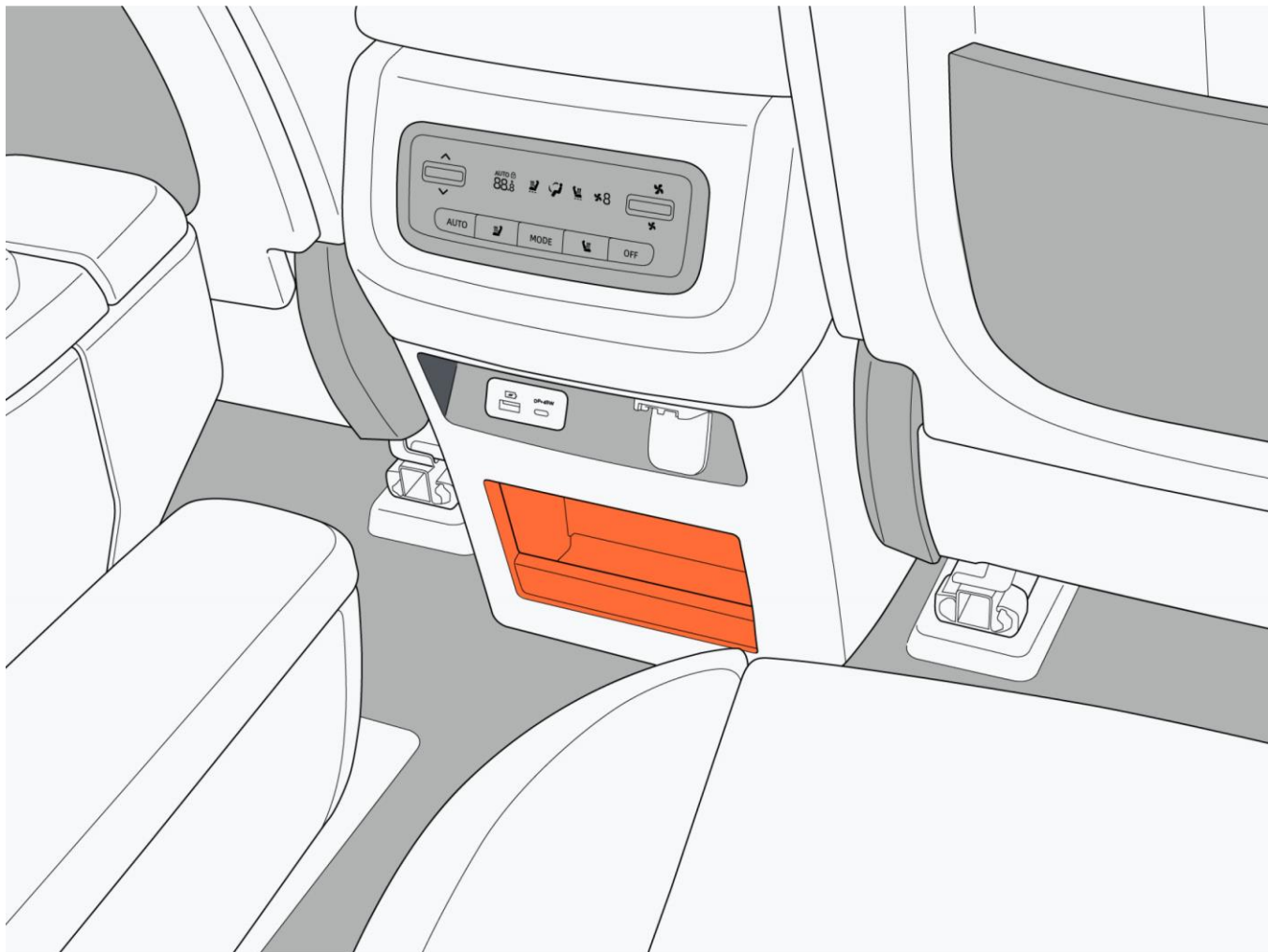



IV. Door storage box

1. Front door storage box

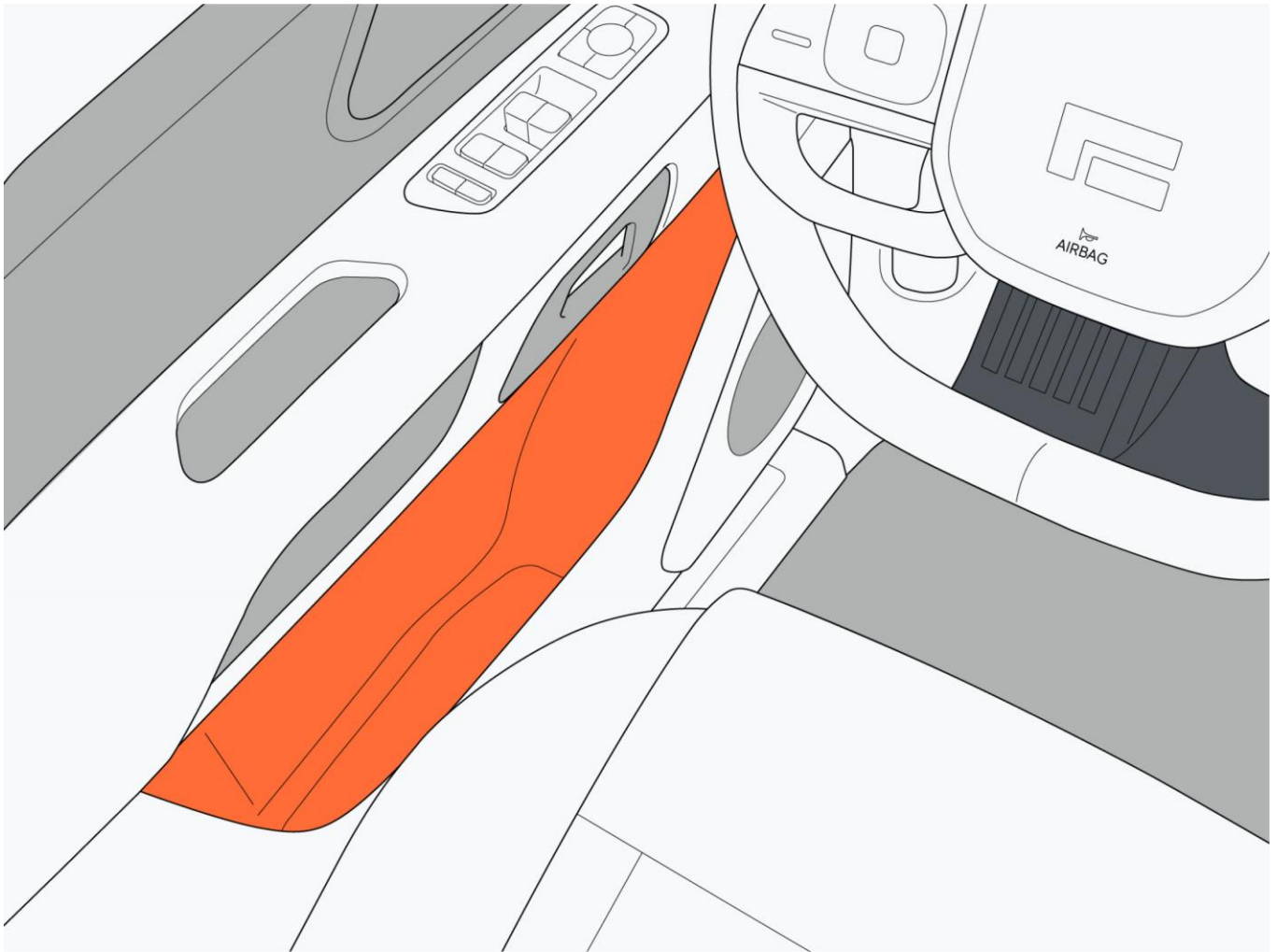

## 6. Operation

### 2. Rear door storage box

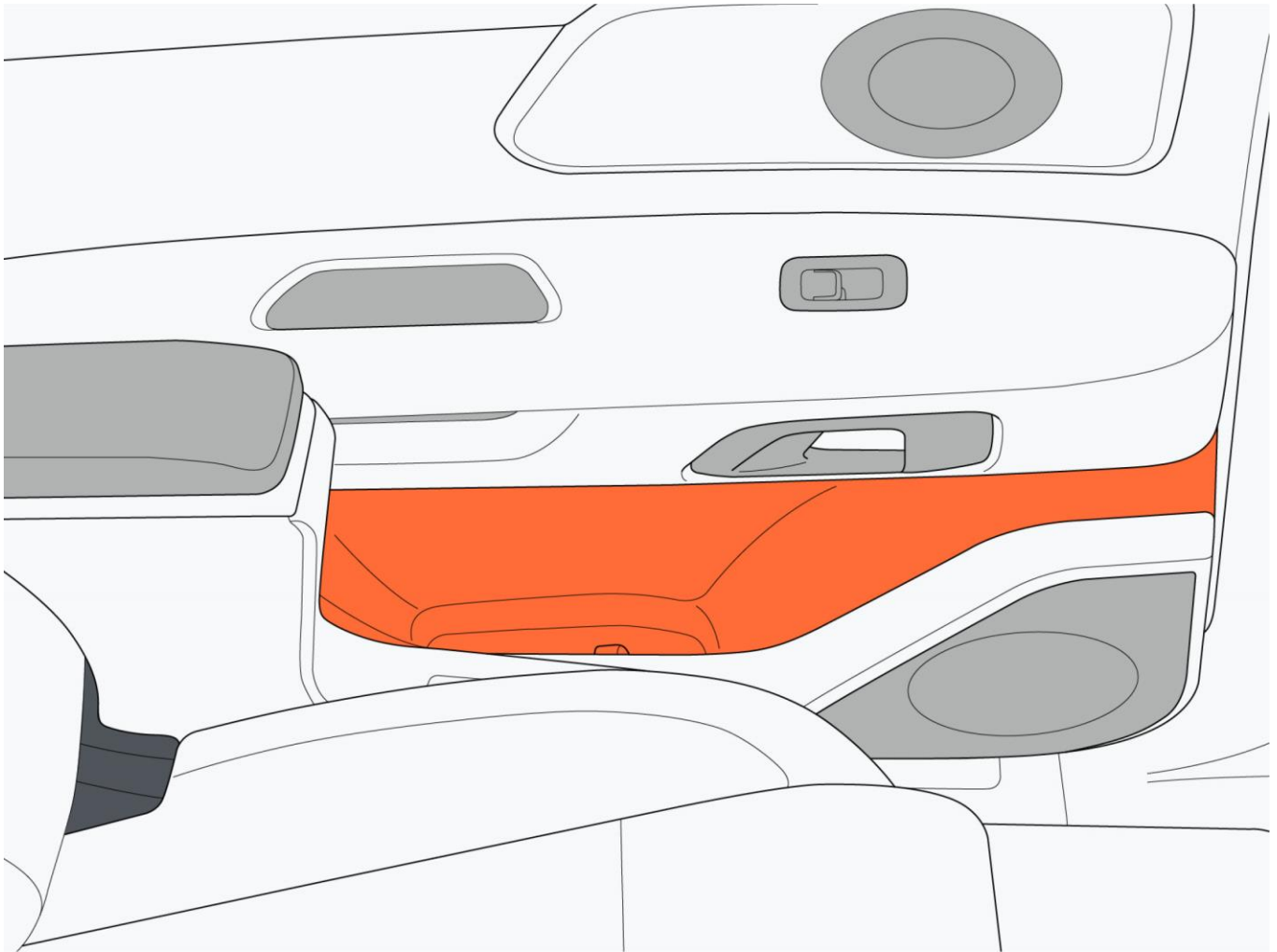



3. Tailgate storage box

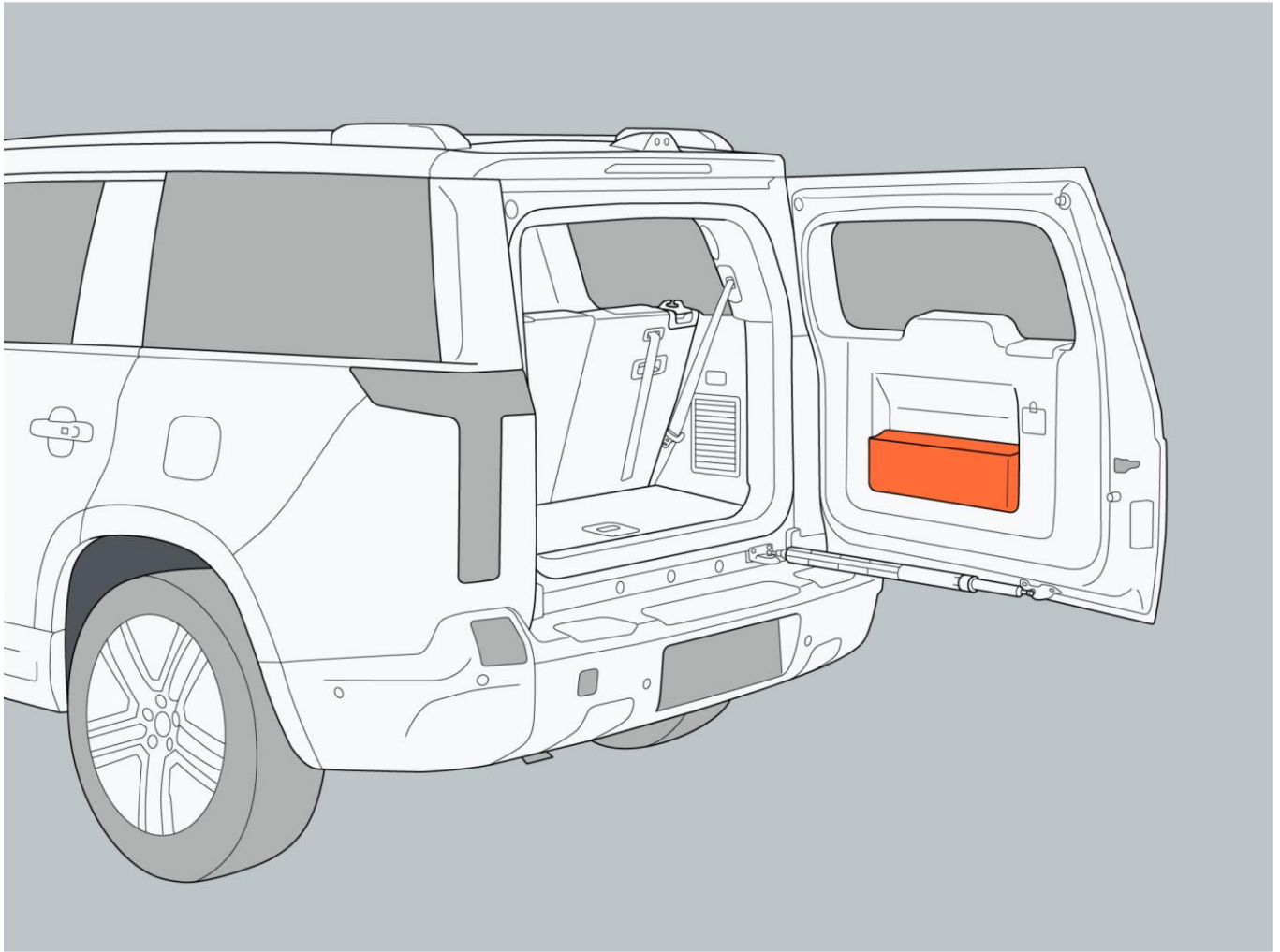

## 6. Operation

### V. Eyeglass case

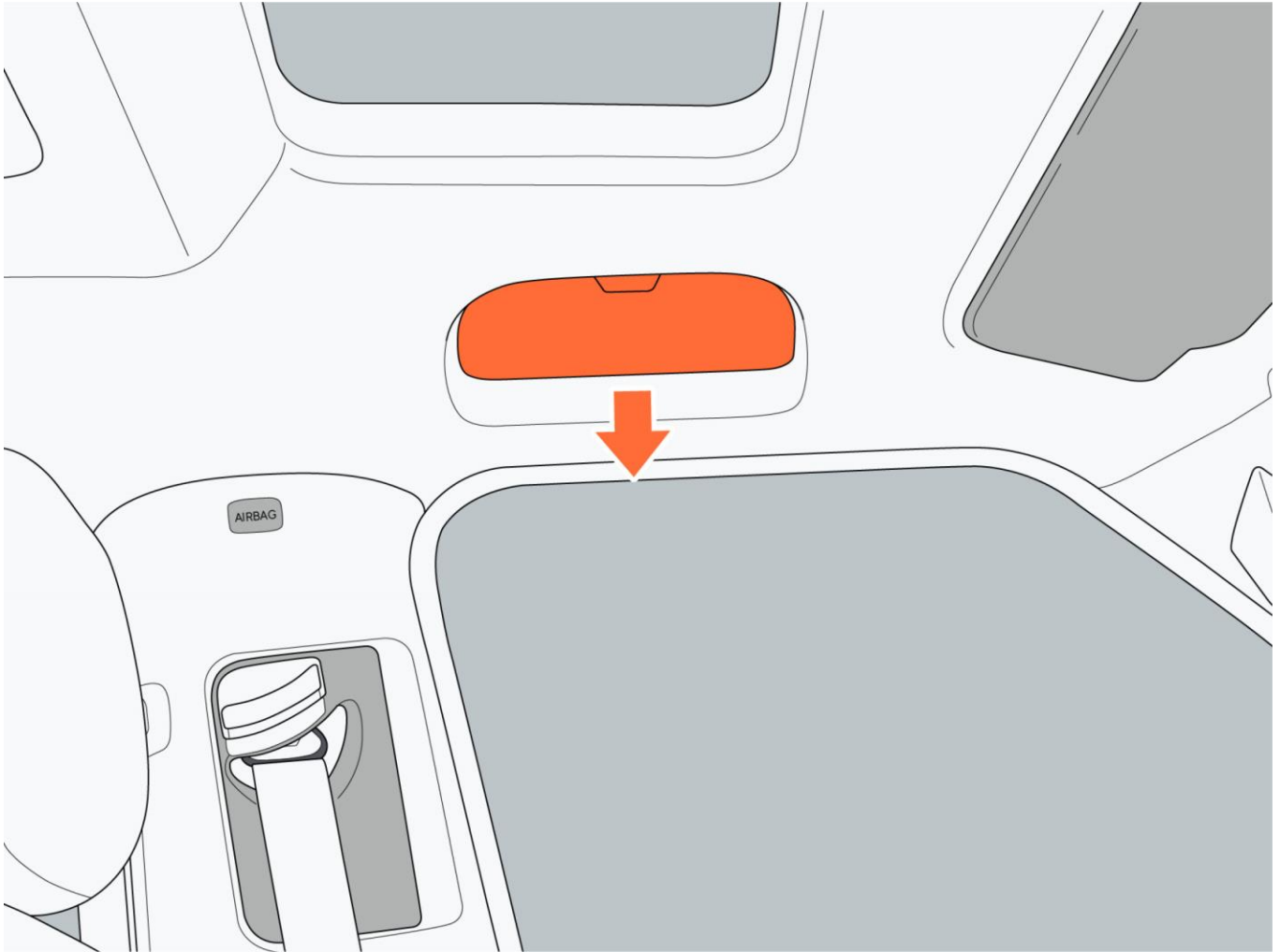

VI. Second-row seat storage pot

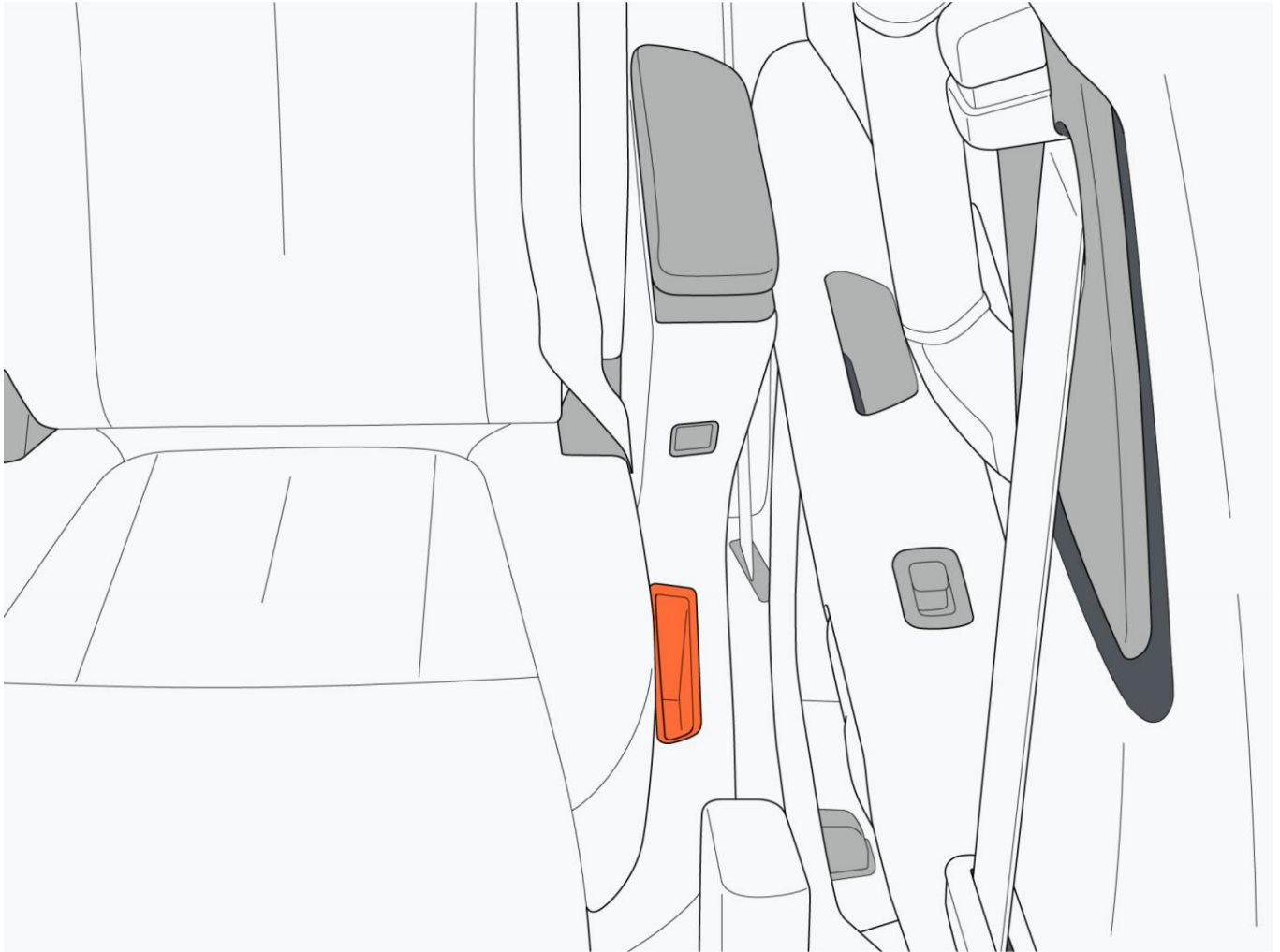

## 6. Operation

### 6.9.3 Cup holder

#### I. Front-row cup holder

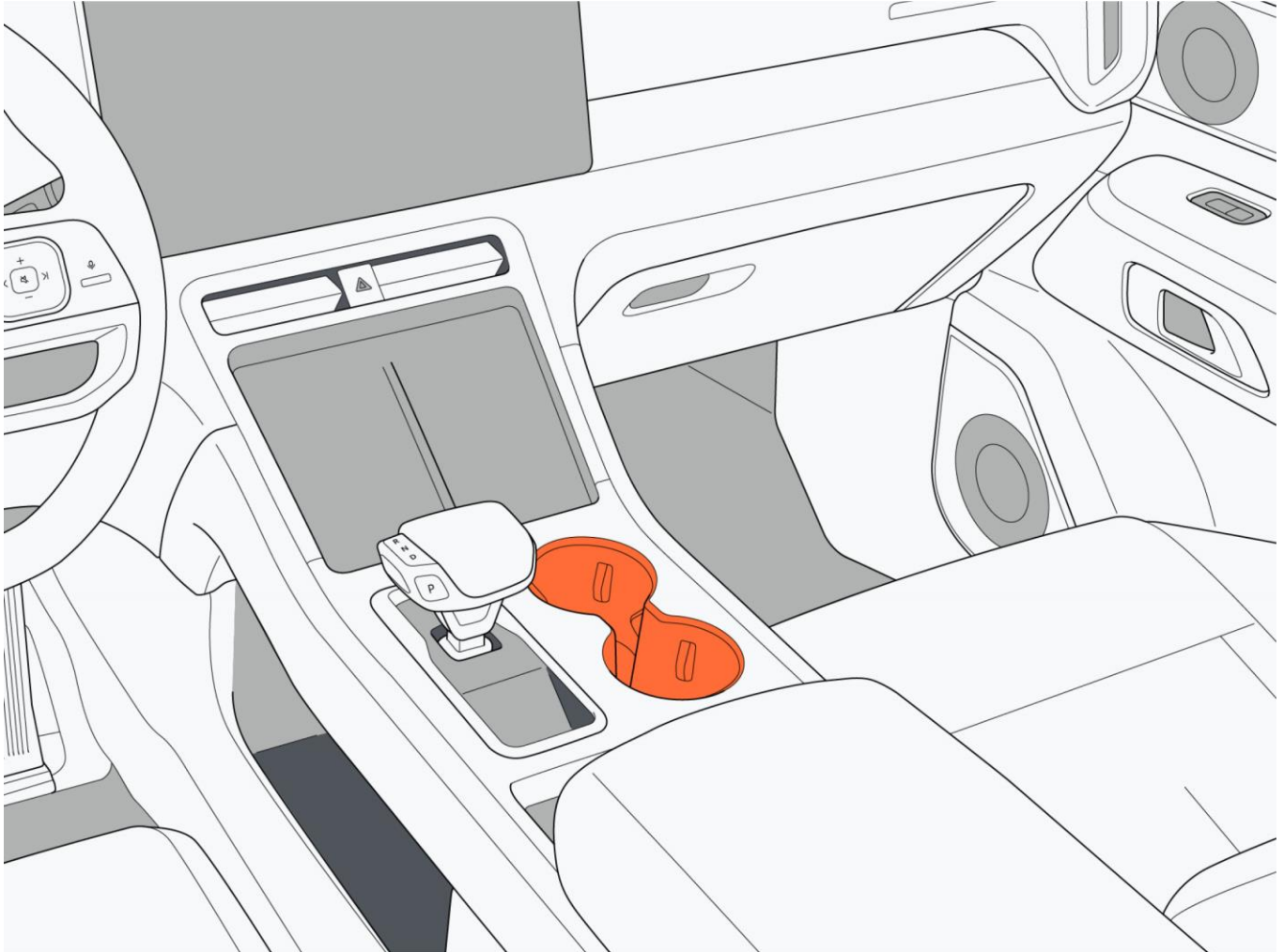

### II. Second-row cup holder

Press the front end position of the side armrest pop out the cup holder. Press it again to retract cup holder.



## 6. Operation

### III. Second-row cup holder (aviation seat)

Press the button on the front of the seat armrest to open the cup holder support.

#### **i** Tip

- The second-row cup holder is close to the seat adjustment panel. When placing the cup, tighten the cup lid to prevent liquid from splashing on the seat adjustment panel and causing damage to the electronics inside the control panel.



### IV. Third-row cup holder

#### Warning

- Do not place anything other than a cup in the cup holder to avoid dropping items or damaging the cup holder.
- When placing a cup with hot water in the holder, tighten the lid to avoid burns.

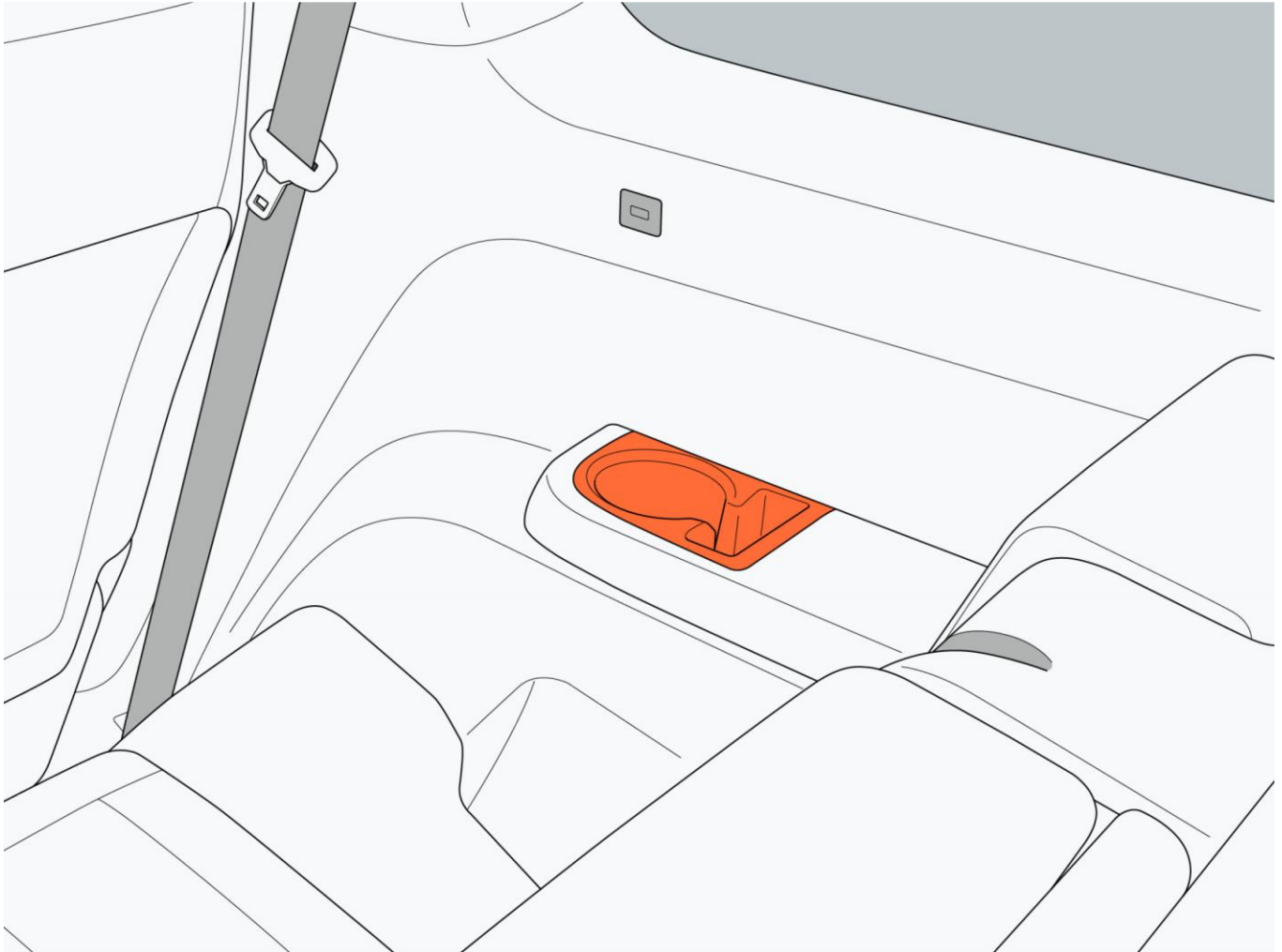



## 6. Operation

### 6.9.4 Seat map pocket

Open the map pocket behind the first-row seat, you can put you book, ipad and other objects in it.

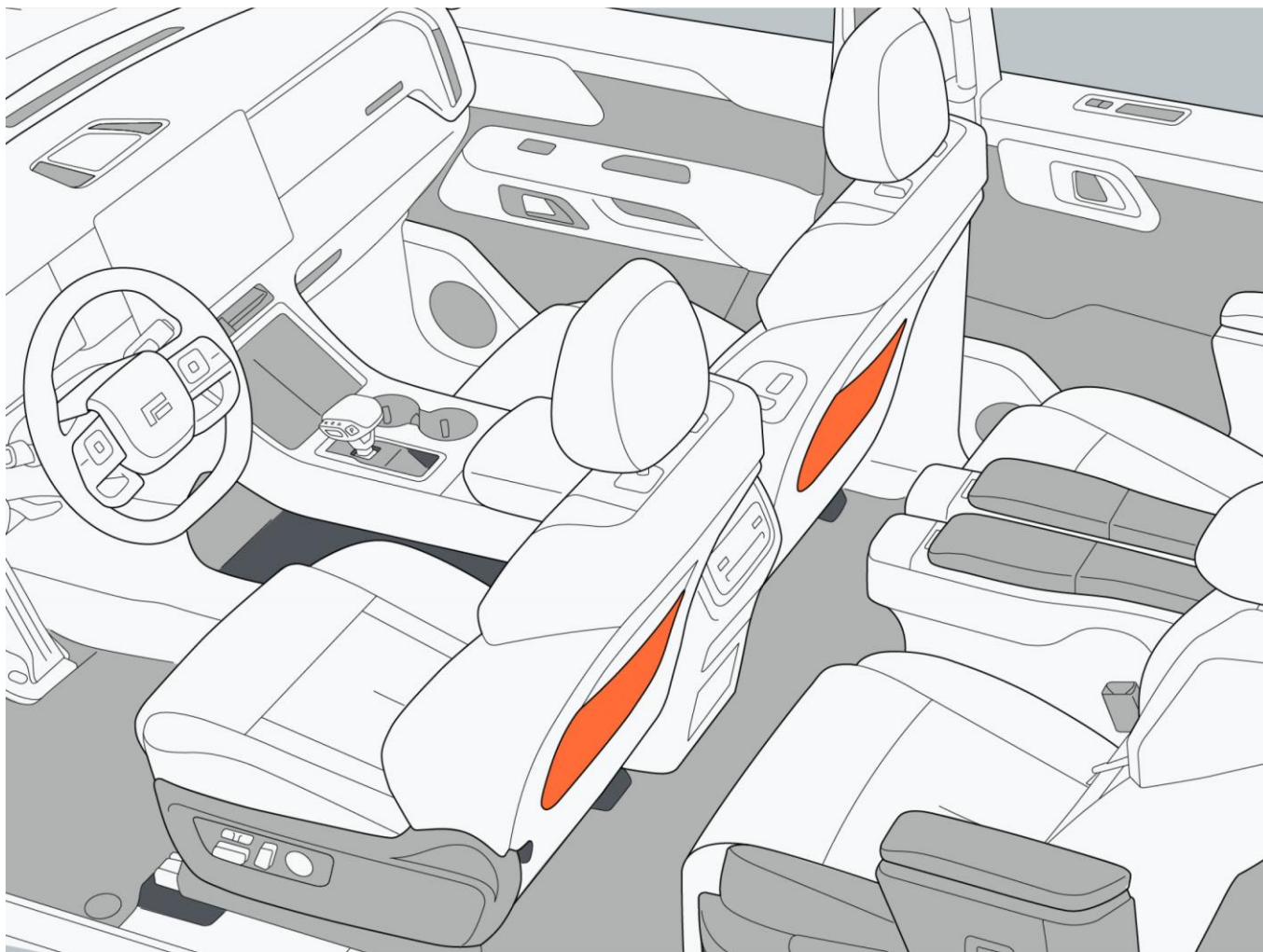



### 6.9.5 Trunk equipment

#### I. Luggage pad

Press the back of the luggage pad handle to lift the luggage pad upwards through the handle.

#### ⚠ Caution

- When placing items in the trunk, the items should be fixed. Unfixed items may cause serious injuries to drivers and passengers in case of a collision or emergency braking.

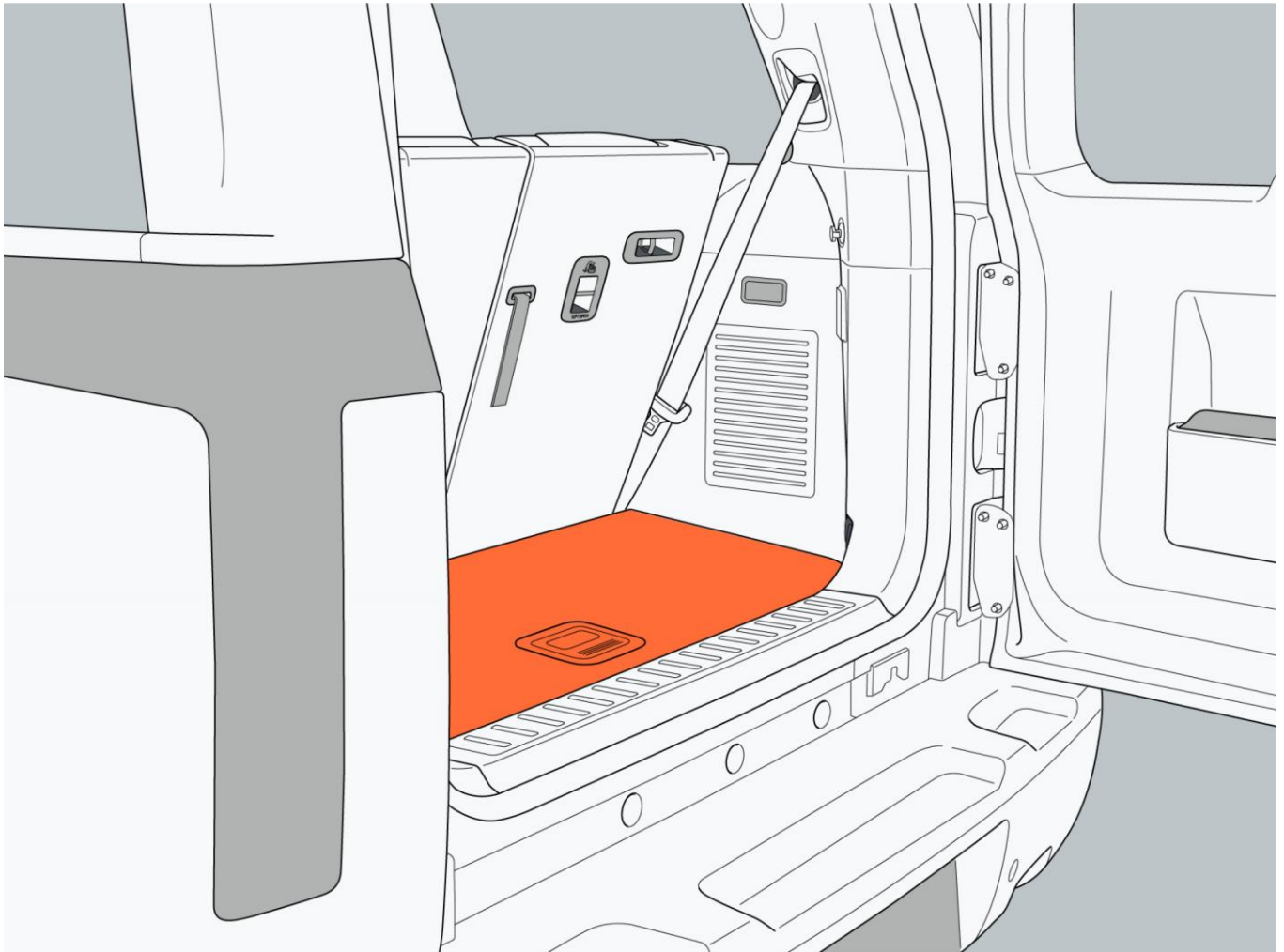

## 6. Operation

### II. Luggage floor hook and hanger

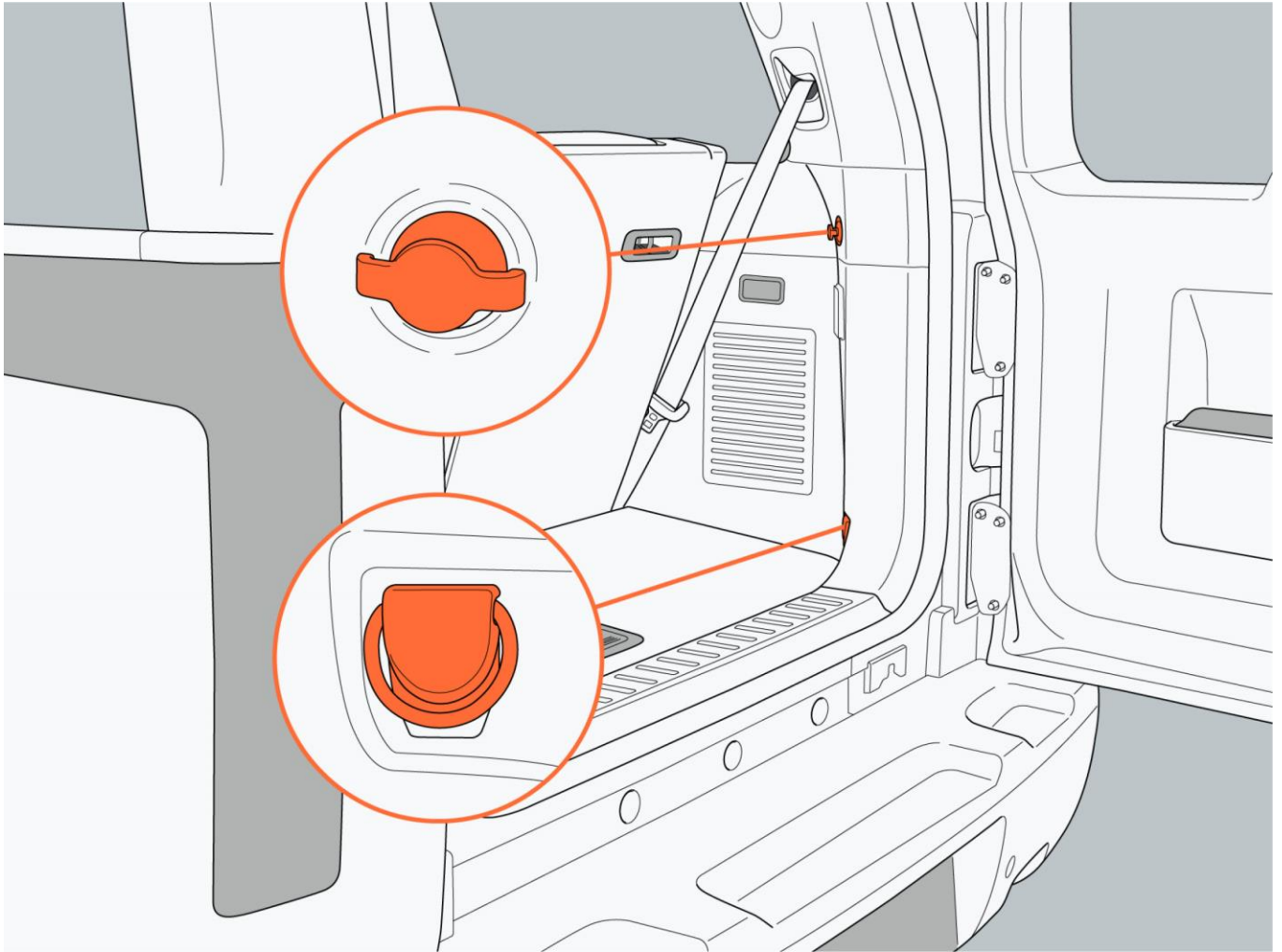

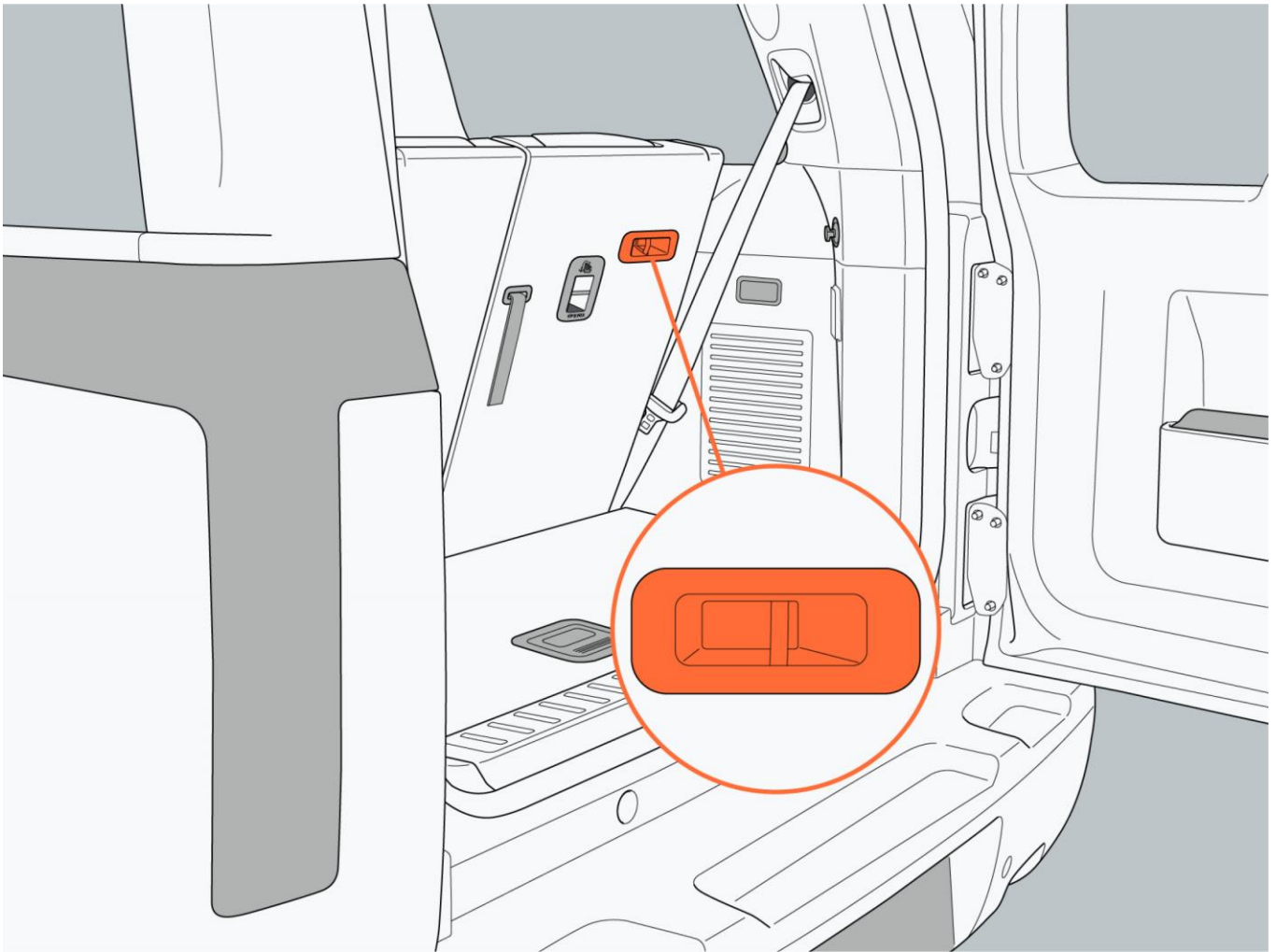

## 6. Operation

### III. Luggage hanger

The maximum carrying capacity of the luggage hanger does not exceed 3 kg.

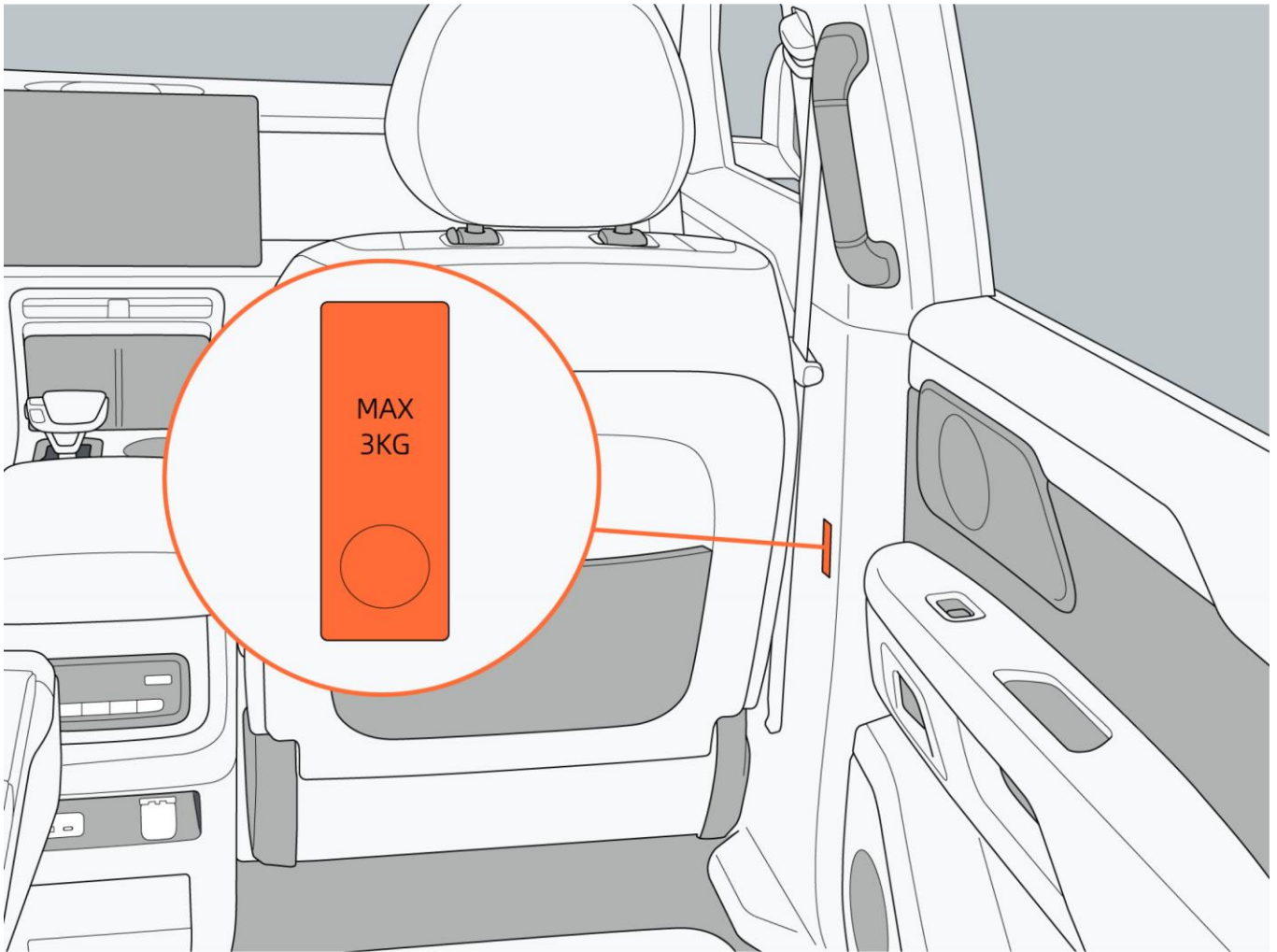

### 6.9.6 Roof rack

In order to ensure driving safety and avoid damage to the roof, please use the roof rack approved by ROX.

Before loading items (such as bicycle, ski, etc.) with the roof rack, first install a transverse support bar, and then fix the load on the transverse support bar. When loading items on the roof rack, follow the following rules:

- Distribute load evenly to avoid overweight on one side.
- Place the heaviest part of the load in the middle of the roof as much as possible.
- Once the transportation is over, immediately remove the transverse support fixing bar installed on the roof rack.
- The loaded items will increase the sensitivity to side wind effects. Please drive with caution.

#### Caution

- The maximum loading mass of roof rack: 100 kg. When calculating roof load, it should include the roof rack and any cargo tools.

- Do not exceed the maximum loading mass of the roof rack.
- If the height exceeds the maximum loading height, make sure to control the speed according to the road surface conditions to avoid damaging the roof rack.
- Comply with the relevant national transportation regulations when transporting super-long and super-wide items.
- If you have to load your vehicle on the roof rack, take special care when driving the vehicle and make sure that the items are securely secured.
- The load of the roof rack shall not exceed the maximum axle load and gross vehicle weight.
- Be sure to fix the object to the side rail, not just the cross rail.
- It is recommended not to drive off-road when there are items on the roof . If you need to place items in the luggage rack during off-road driving, you should unload the items before passing the side slope.

## 6. Operation

### 6.10 Other onboard equipment

#### 6.10.1 Sunshade

1. Front shielding: Turn down the sunshade and place it in the front position.
2. Side shielding: Turn down the sunshade first, then take off the hook and rotate it to the side.

#### 6.10.2 Vanity lamp

Open the vanity mirror cover to use the vanity mirror.

##### **i** Tip

- Open the vanity mirror cover and the vanity lamp light is up. Close vanity mirror cover, and the vanity mirror light is off.

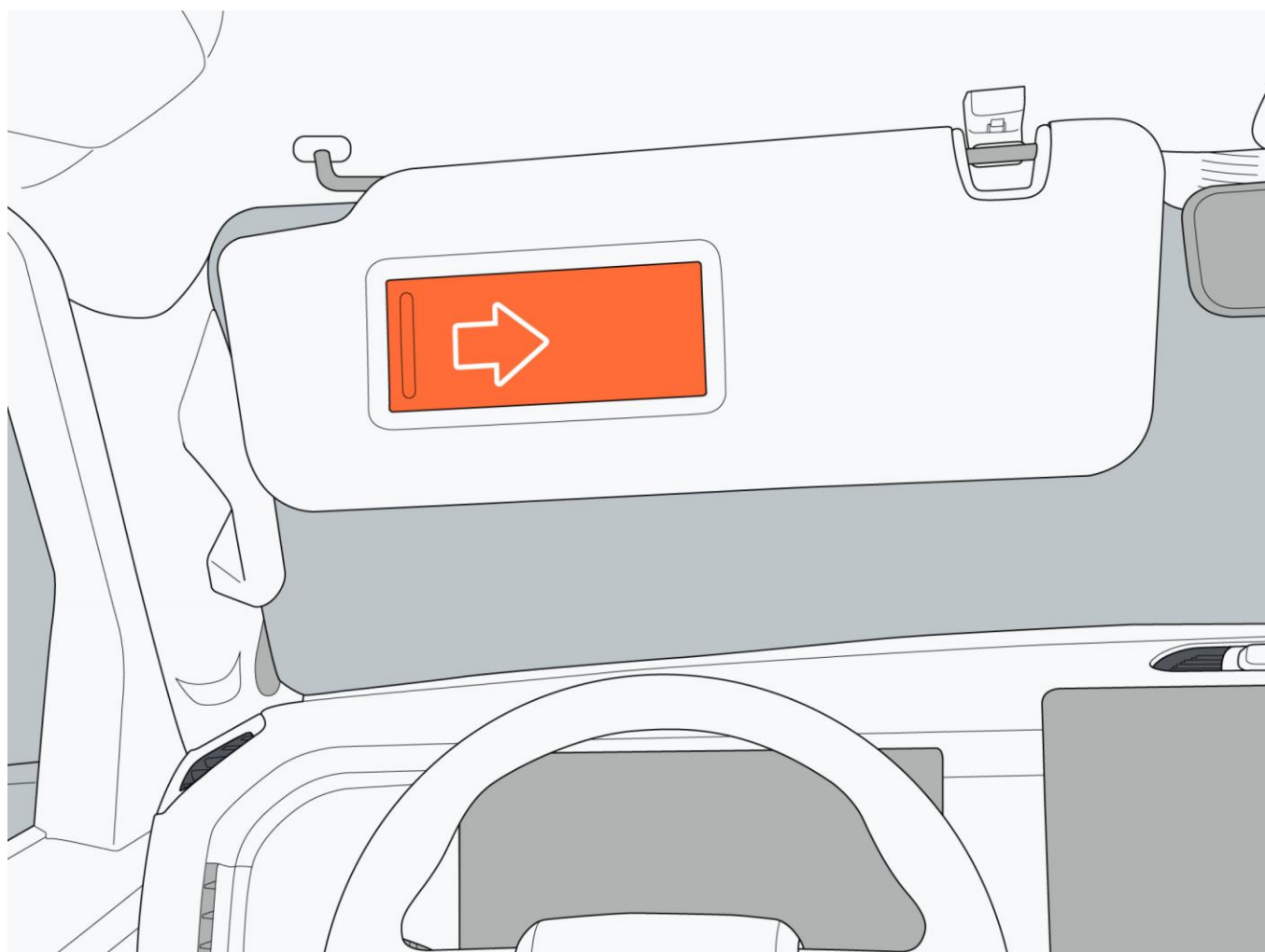

#### 6.10.3 12V power socket

The 12V power socket is located in the lower part of the A/C control panel of the second row. When the vehicle power is in non-“ OFF” mode, a 12 V power socket can be used to power devices below 12 V.



**Warning**

- Do not use electrical equipment with a power exceeding 180 W on 12 V power sockets, to avoid burning fuses or lines due to excessive current, and causing fire.

**Tip**

- When the 12 V power socket is not in use, close the power socket cover to avoid damage caused by foreign objects or liquids entering the power socket.

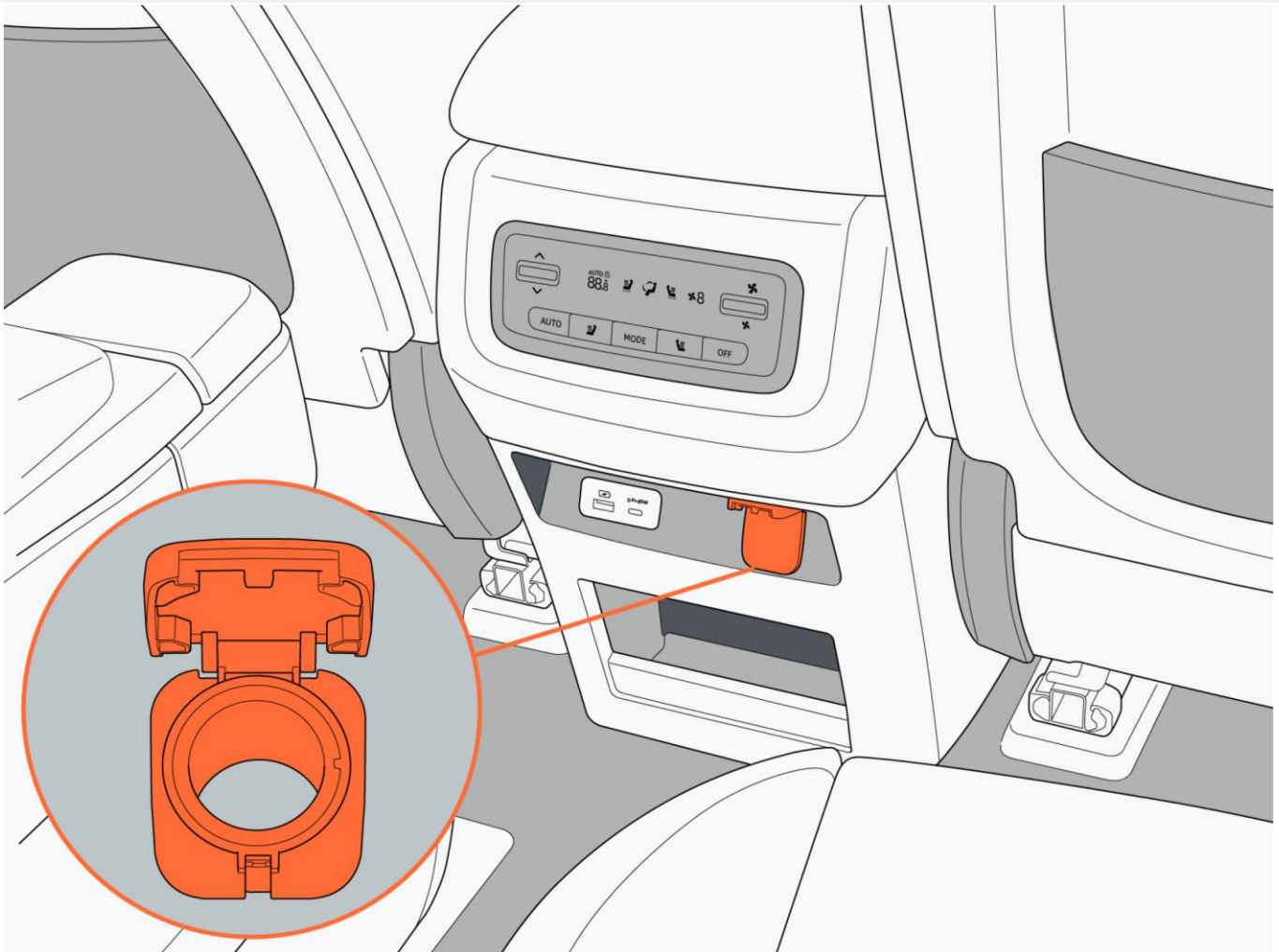

#### 6.10.4 220V power socket

The 220 V power socket is in the trunk.

When the power of the vehicle is in non-“OFF” mode, a 220 V power socket can be used to supply power to electrical equipment with a rated working voltage of 220 V and a maximum power of no more than 2,200 W.

The 220 V power socket will automatically turn off or cannot be turned on if:

- The power battery level is too low.
- The 220 V power supply automatically turns off after the vehicle is locked and powered off.
- The vehicle power supply is in “OFF” mode.
- The power of the electric device is too high.

## 6. Operation

- The system is faulty.

### Warning

- Do not use equipment with a power exceeding 2,200 W on a 220 V power socket, to avoid burning the line or even causing fire due to excessive current.
- Keep children away from 220 V power sockets to prevent from inserting fingers or objects into the sockets, which may cause electric shock or damage the outlets.

### Tip

- When the 220 V socket is not in use, close the power socket cover to avoid damage caused by foreign objects or liquids entering the power socket.
- Plugging in the overloaded electrical appliance and starting and stopping frequently may trigger the 220 V power socket to enter the protection mode. If the 220 V power socket is not available, unplug the electrical appliance and wait for a period of time and re-plug the electrical appliance to try to start the 220 V power supply.

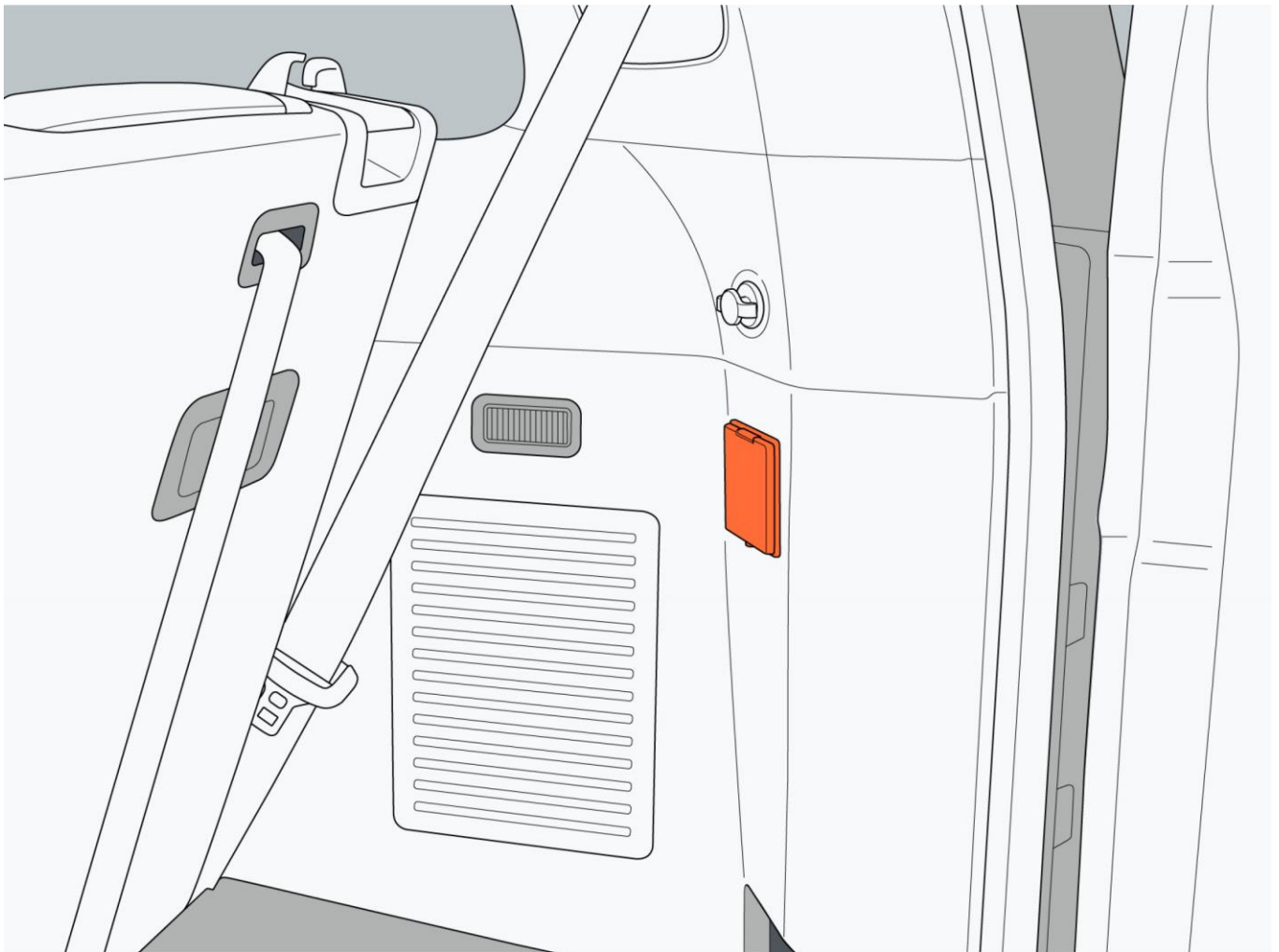

I. Activate/deactivate



Click “Discharge Management → Power Socket” through the central control screen to set the turning on and off of the 220 V power socket.

### 6.10.5 Wireless charging

When the vehicle power is in “ON” or “READY” mode, the device with wireless charging function can be placed on the wireless charging panel for wireless charging. There are two wireless charging panels on the front of the center console of the vehicle. Place the device flat in the charging area while charging.

Click “Vehicle Settings → Accessories → Wireless Charging” through the central control screen. Click the “Main Driver” or “Front Passenger” switch to set the wireless charging function of the driver or front passenger to turn on and off.

#### Caution

- The mobile phone wireless charging function only supports mobile phones that satisfy the wireless charging protocol.
- It is normal for the device to heat up during charging.

#### Tip

- When the device is charging, if the driver door is opened or the driver leaves the seat, the vehicle will send a device forgetting prompt message through the mobile APP.
- When the device is charging, if the driver's door is opened and the driver leaves the seat, the vehicle will give a prompt sound.

## 6. Operation

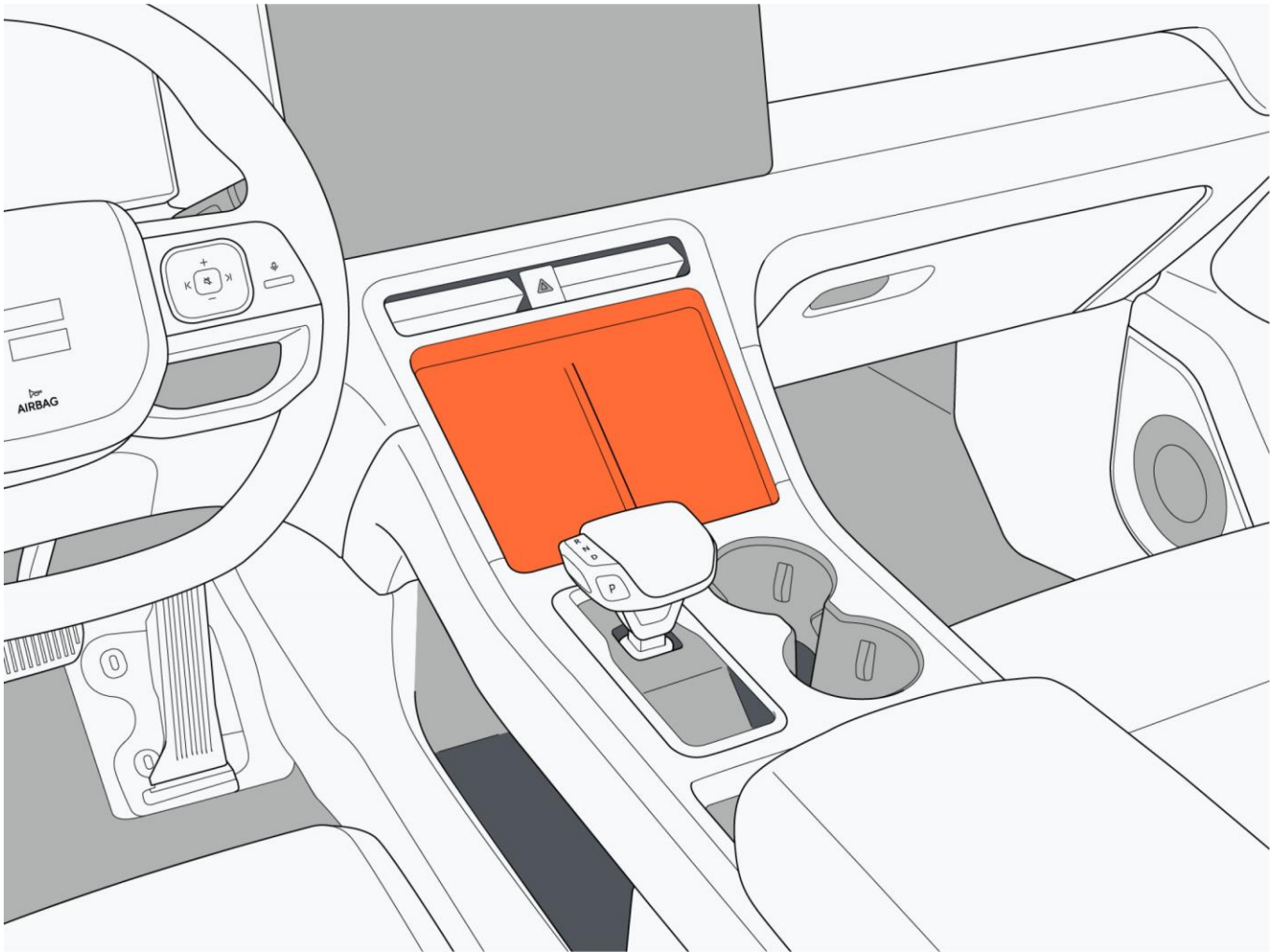

### 6.10.6 USB power interface

#### I. Front row

1. The front-row USB interface is located in the storage pot under the center console.

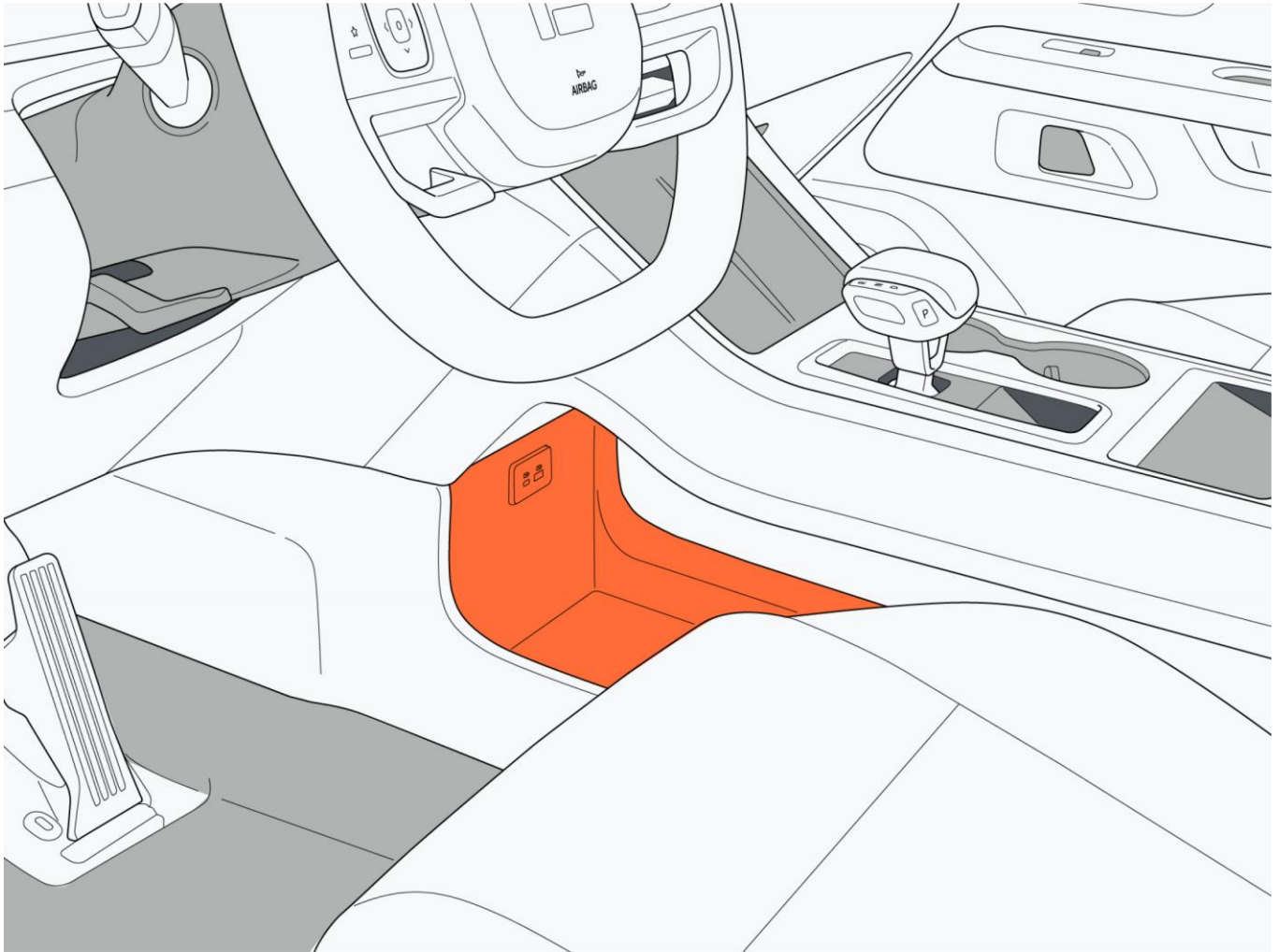

## 6. Operation

2. The front-row USB interface is located in the armrest box.

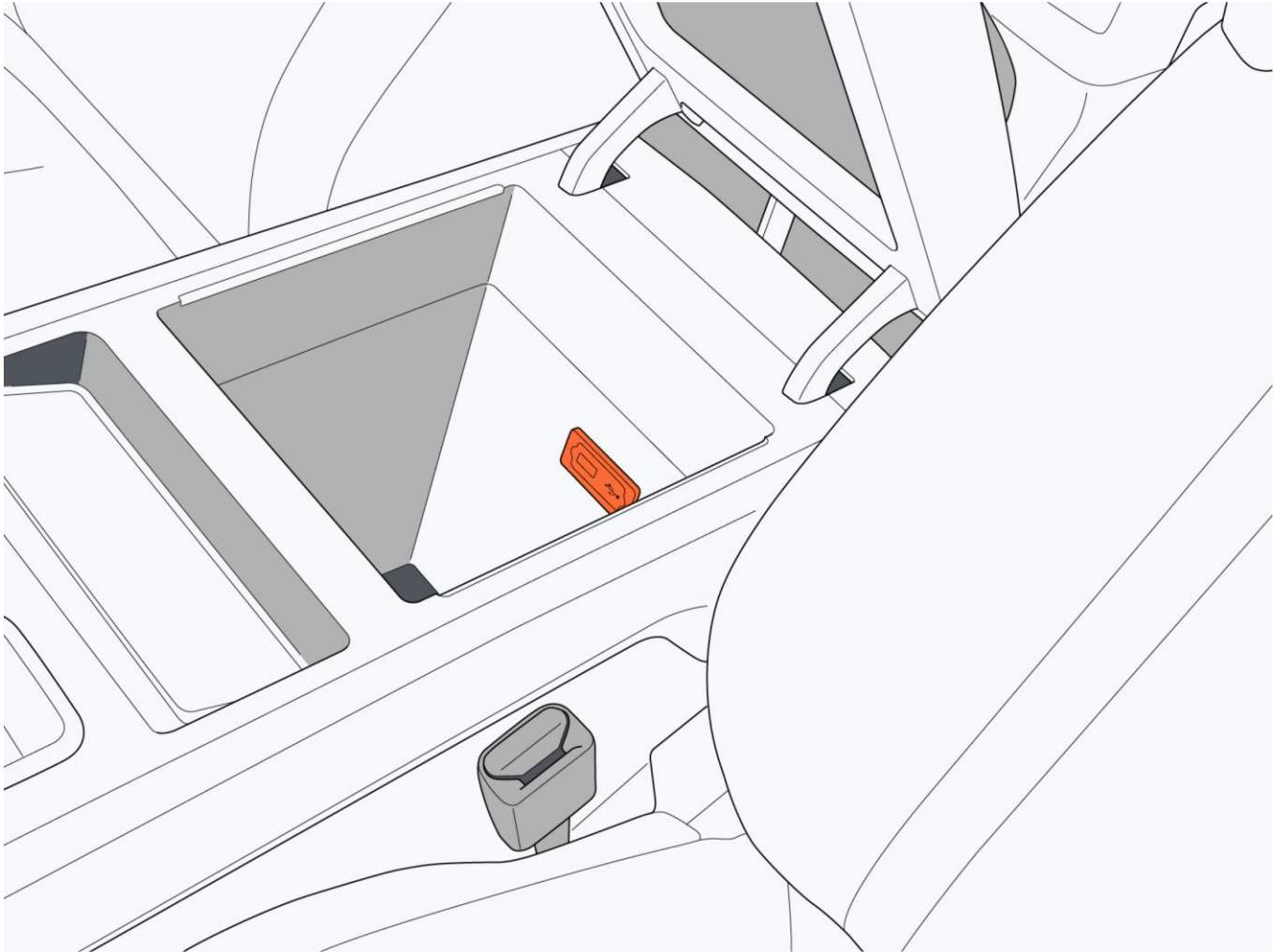

### II. Rear row

1. The rear-row USB power interface is located in the lower part of the A/C control panel of the second row.

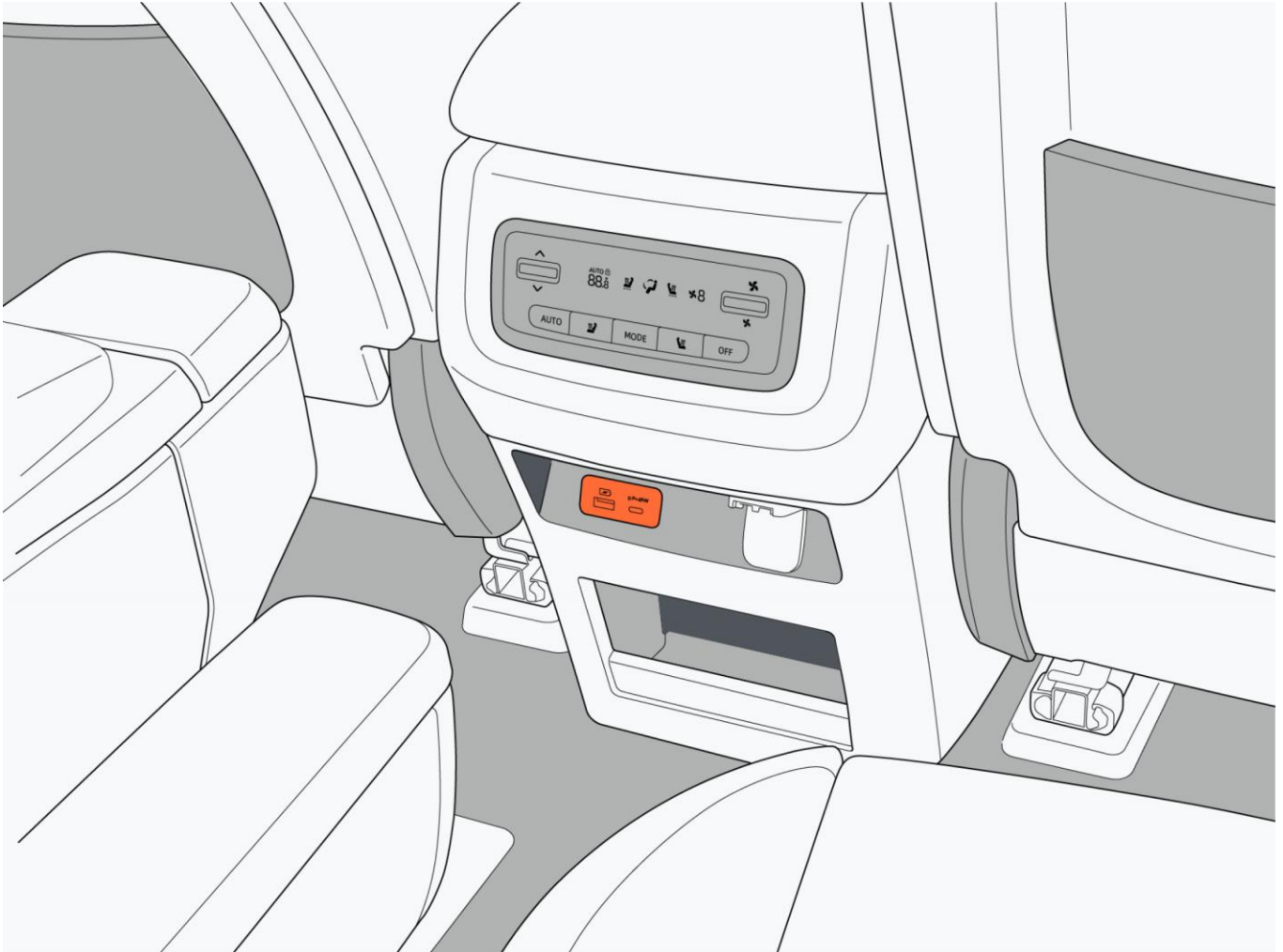

## 6. Operation

2. The USB power interface is located on the side of the second-row aviation seat.

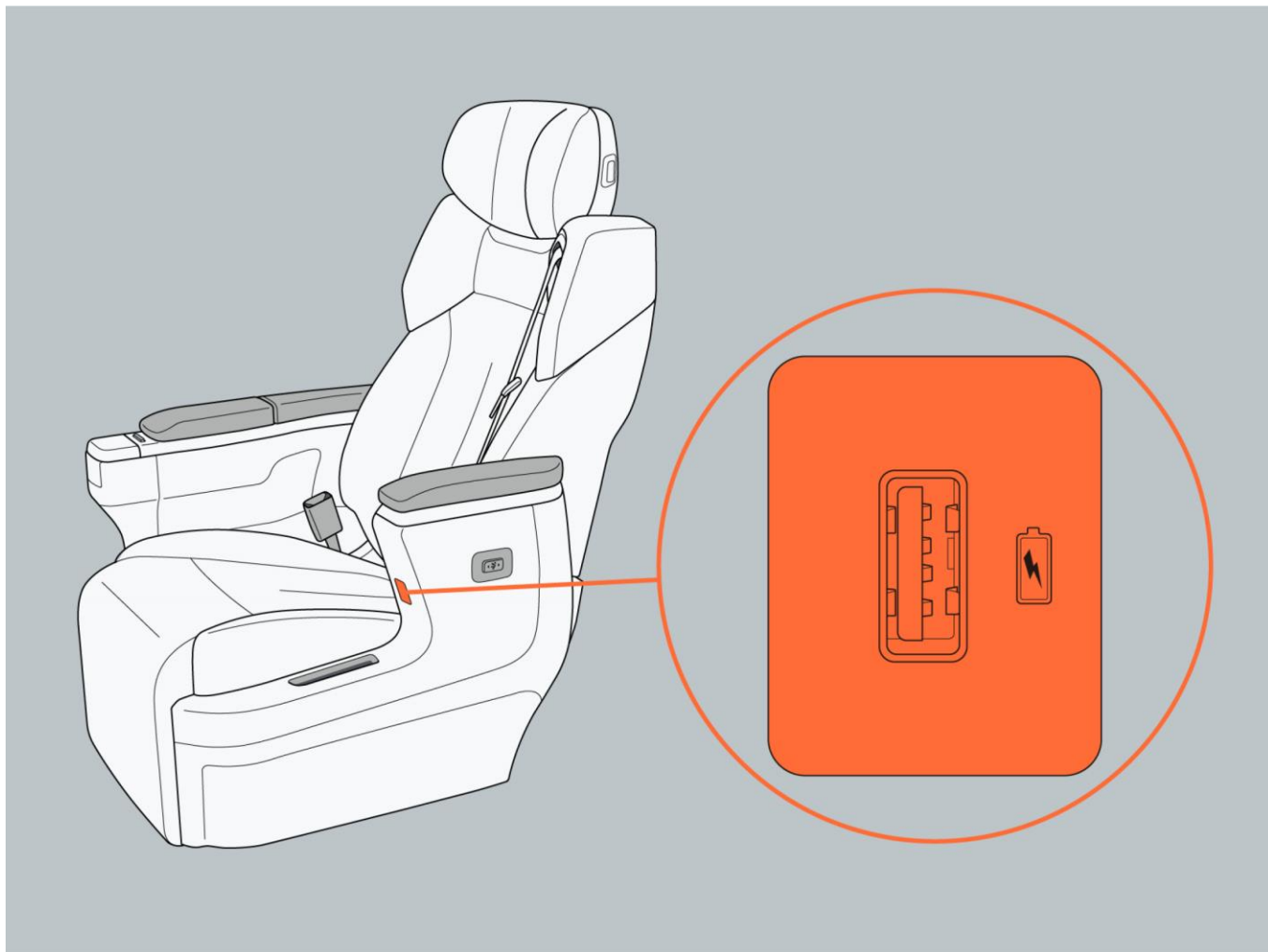

### III. Third row

1. The third-row USB power interface is located above the left/right seat armrests.

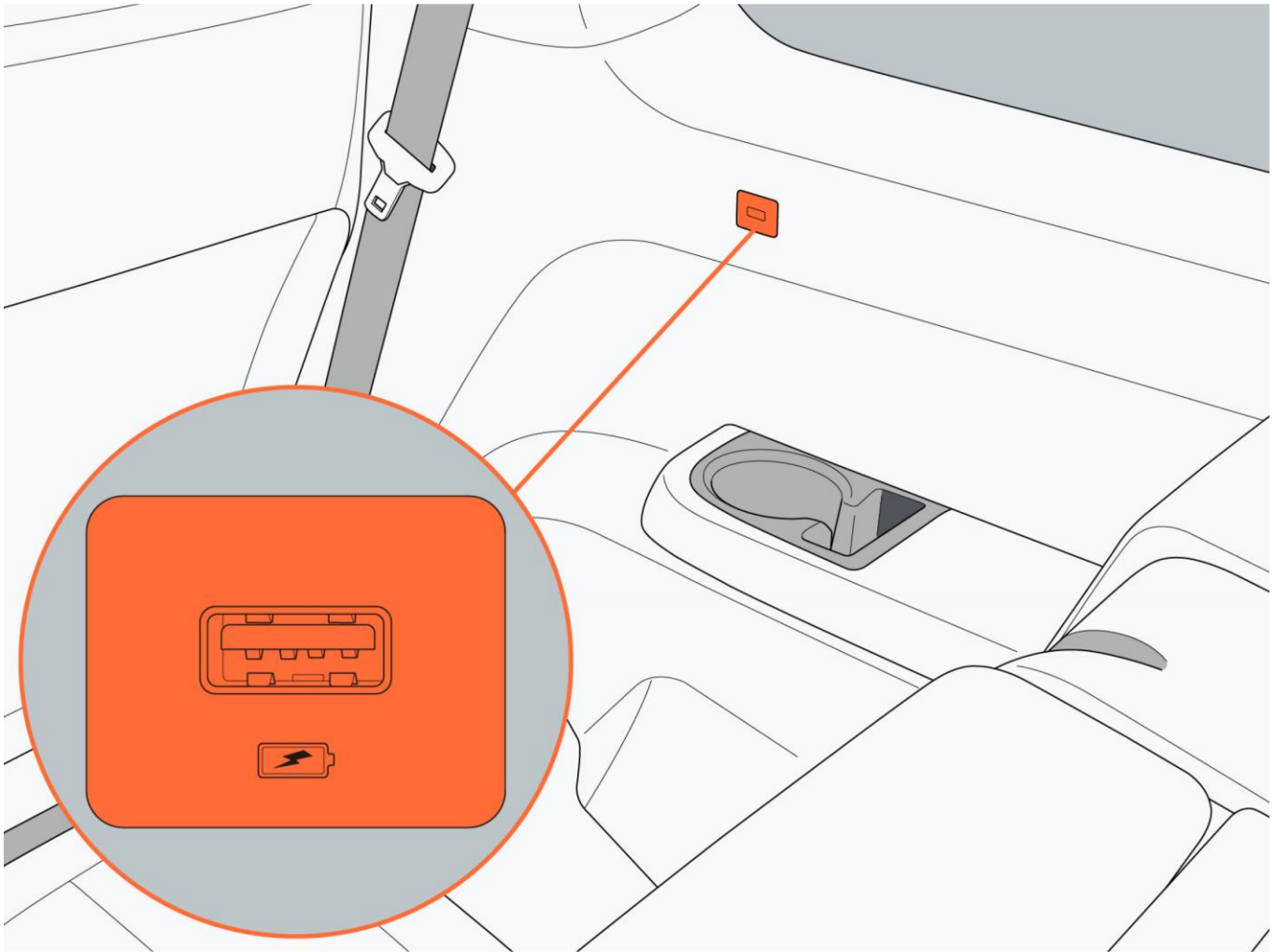



## 6. Operation

### 6.10.7 Driving recorder

#### I. Interface instruction

Click “Driving Recorder” through the central control screen to enter the driving recorder interface:

- Real-time picture: Display the picture recorded by the current driving recorder.
- Album: Click to enter the album to view and manage photos, videos, emergency videos, sentinel views and collections.
- Settings: Click to enter the driving recorder settings interface.

#### II. Cycle recording

When the vehicle power is in the “READY” mode, the driving recorder will start automatically to enter the cycle recording. Record circularly based on the set cycle recording duration. The cycle recording durations are 5 min, 3 min and 1 min respectively.

#### III. Emergency recording

During driving, the vehicle will enter the emergency recording in case of a collision. The driving recorder will record video images 15s before and after the collision, and record instantaneous photos at the time of the collision.

#### Tip

- Recorded video files are stored in the album.
- According to requirements of data security regulations, pedestrian facial features and license plate information outside the vehicle belong to private information and are protected. If you need to use and share driving images, please abide by the requirements of laws and regulations.
- Short press the steering wheel customization button to trigger the emergency recording of the driving recorder.

#### IV. Driving recorder settings

- Click “Settings” through the driving recorder interface to enter the driving recorder setting interface.
- Auto-recording upon startup: When the power supply of the vehicle is in the “READY” mode after turning on, the driving recorder is enabled and starts recording.
- Driving information superposition: After turning on, the driving recorder interface or preview interface will display the speed information, location and other information in the video.
- Sound recording: It is in “Off” by default. Video files will contain audio when turned on.
- Video resolution: The driving recorder video resolution defaults to 1080p. 1080P or 720p can be set.
- U disk management: Display the occupancy of the current capacity by videos and photos in the flash drive.
- Formatting: Click the icon to pop up the prompt box. Then click the prompt box “OK” icon to format the flash drive.



### 6.10.8 Microphone

The vehicle is equipped with 5 microphones, located next to the front reading lights and beside the left and right assist grips. During the call or voice dialog control scenarios, they record the sound in the car.

#### Caution

- Do not insert sharp objects into the microphone mesh cover to avoid damaging the microphone.

### 6.10.9 Assist grip

When the vehicle is moving rapidly or shaking, occupants can maintain their body balance through the assist grip. When using the ceiling assist grip, the assist grip needs to be unfolded. When not in use, release the assist grip, and it can return to its original position.

#### Warning

- Do not hang heavy objects or place heavy loads on the assist grip to avoid damage.

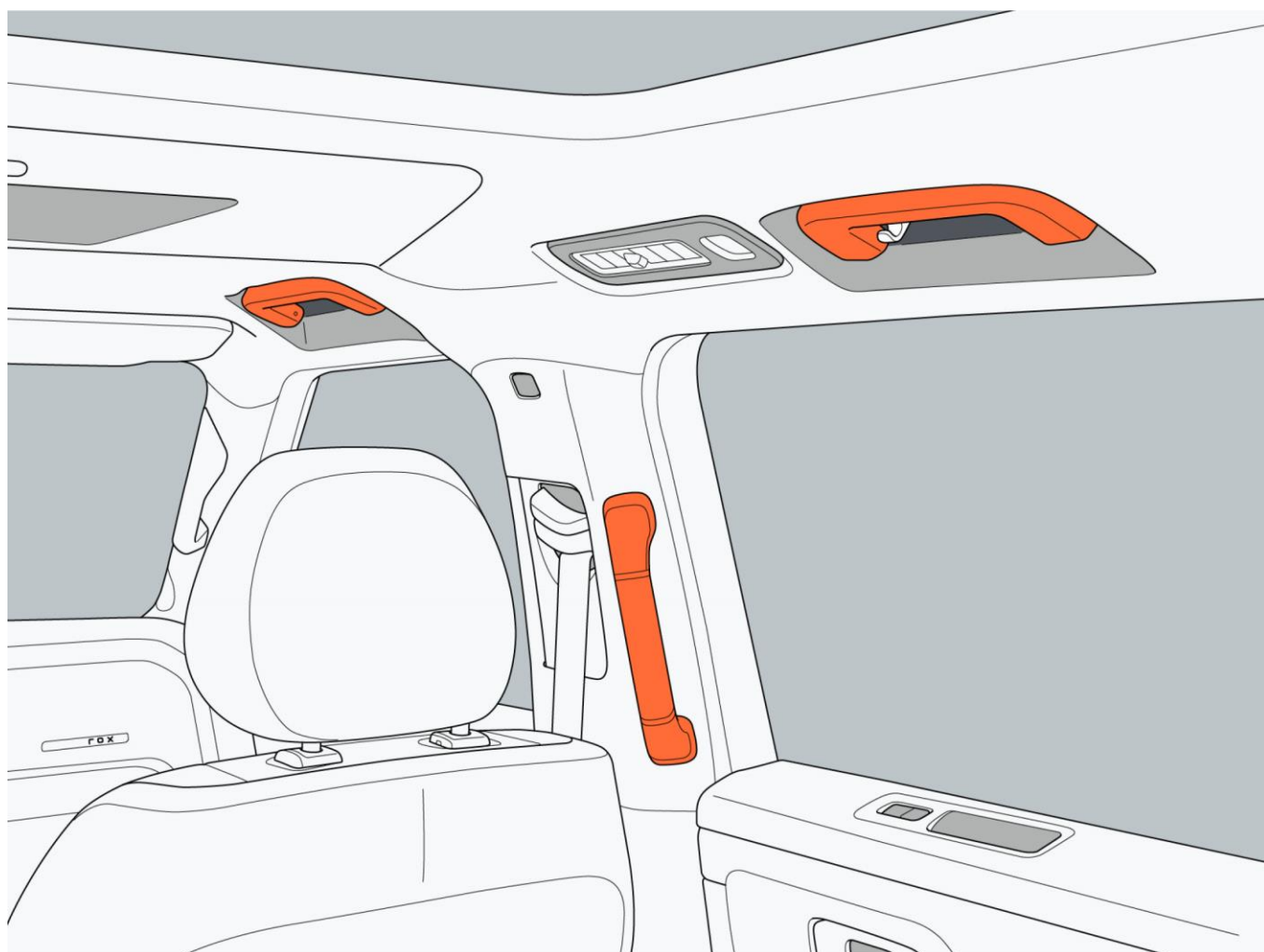

## 6. Operation

### 6.10.10 Coat hook

There are coat hooks attached to the ceiling assist grips above both sides of the second-row seats, which are only used to place coat and hat items.

#### Warning

- Do not hang other hard items on the coat hook. When the side air curtain is unfolded, these items may pop out and result in an accident.

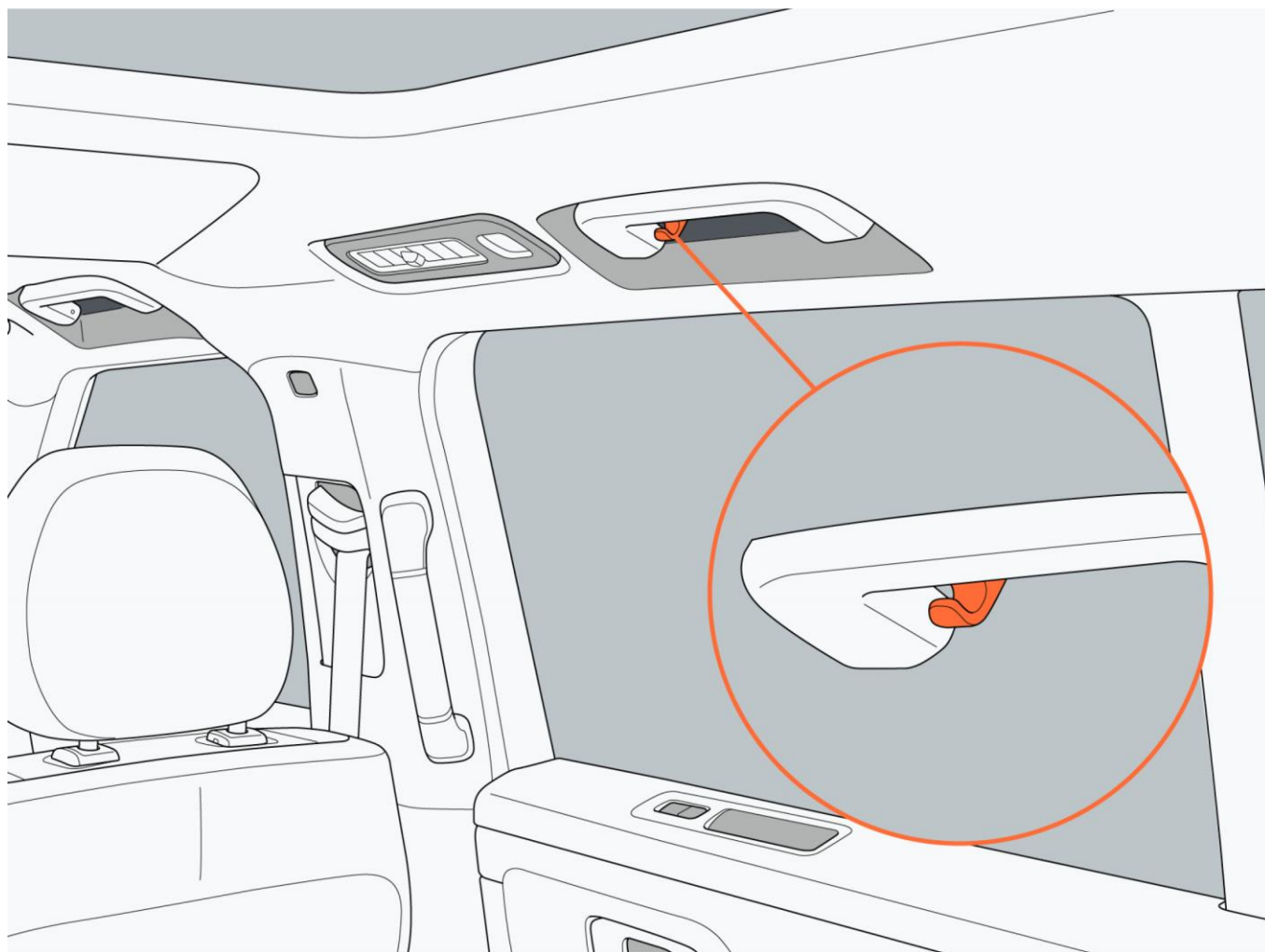

## 7.1 Before driving

### 7.1.1 Driving vehicle

#### 1. Pre-trip inspection

Before traveling, confirm that there is no battery system alarm information on the instrument screen. If there is a failure of the power battery system, you should immediately contact the ROX Service Center for inspection.

#### 2. Start the vehicle

Carry the remote key, press the brake pedal, and the “READY” indicator on the instrument screen is on. At this time, the vehicle is drivable.

#### 3. Vehicle starting

After starting the vehicle, switch the gear to D, gradually release the brake pedal, and lightly press the accelerator pedal to accelerate the vehicle.

#### 4. Parking

Press the brake pedal to stop the vehicle completely. Switch the vehicle gear to P gear, and close and lock all doors.

#### Warning

- Do not operate the shift handle at will while the vehicle is driving. This can avoid accidents caused by sudden shift of gears.
- Do not press the accelerator pedal when operating the shift lever. This can avoid traffic accidents or casualties caused by sudden acceleration when switching gears.
- Do not drive on a road section where the depth of stagnant water is unknown. This can avoid damaging electrical parts or the range extender.
- Do not protrude any part of your body out of the car while driving.
- Do not run the range extender system for long time in a poorly ventilated or closed place to avoid exhaust gas poisoning.
- Do not overspin when any tire is suspended or the vehicle is stuck in sand or mud. This can avoid accidents caused by sudden acceleration.
- Do not park your vehicle near flammable and explosive materials to avoid causing fire.
- Do not put fragile items in storage devices to avoid damage to items due to bumps.
- Do not apply sudden braking, rapid acceleration, or sharp steering on slippery surfaces to prevent reduced or complete loss of vehicle control.
- Do not drive over flammable materials, and avoid damaging the vehicle or even causing a fire due to flammable materials burning.
- Do not stop on a ramp by using the accelerator pedal or pressing the accelerator pedal and brake pedal at the same time.

## 7. Driving

### Caution

- When going down a steep slope, it is recommended to use the hill descent control to maintain a stable speed.
- When driving on a bumpy road, it is recommended to drive at a low speed to avoid damaging wheels or the bottom of the vehicle.
- When the vehicle needs to wade, check the water depth first to ensure that the vehicle can pass safely. After passing safely, lightly press the brake pedal to keep the brakes dry, and make sure that the brake system works properly.
- After driving on a wading road and the vehicle enters water, drive the vehicle to the ROX Service Center for inspection.
- Flat or damaged tires can cause the vehicle to sound abnormally, vibrate, difficulty to control, or tilt abnormally. When the tire is flat or damaged, you need to hold the steering wheel firmly and press the brake pedal slowly.

### 7.1.2 Cargo and luggage

Items placed in the trunk can be fixed with a luggage retaining ring to avoid damage to items due to vehicle shaking or affecting driving safety due to luggage shaking.

### Warning

- Do not store fragile, flammable and explosive dangerous articles in the trunk to avoid fire, explosion or article damage.
- Do not drive the vehicle when the load is unevenly distributed. This can avoid losing the balance of the vehicle when turning.
- Be sure to secure the cargo in the trunk. Otherwise the cargo may be thrown into the compartment during emergency braking.
- Do not drive the vehicle when it is overloaded. This can avoid accidents caused by excessive inertia and excessive braking distance.

### 7.1.3 Trailer towing

The car towing assembly is a spherical coupling conforming to regulation ECE R55, which can support towing accessories (such as trailer, RV, bicycle, etc.).

Towing a trailer and carrying accessories can increase vehicle weight and drag. As a result, the mileage can be significantly reduced when towing a trailer. Although the vehicle mileage calculator attempts to adjust the mileage estimate based on the mounting bracket, the actual energy consumption may vary. You need to reasonably plan the trip length and destination before traveling.

To install and use the accessory bracket, a towing device must be attached. Follow the instructions provided by the attachment bracket, and comply with all local regulations and legal requirements applicable to carrying attachments.

The vehicle towing assembly includes wiring required to be equipped with lights for the accessory bracket. When towing attachments, regularly confirm that the attachment bracket and its cargo are always in a safe state. Also confirm that the lights on the attachments are working properly.

### Warning

- Do not install an accessory bracket on the vehicle that is not equipped with towing assembly.
- When loading and towing, comply with applicable local laws and regulations.

### Caution

- The towing device may obscure the view of the exterior rearview mirror, rear camera and rear ultrasonic-wave sensor. In addition, some assist driving functions may not work properly.
- Make sure to use a suitable disconnect towing cable or secondary hitch. For guidance, refer to the trailer manufacturer's instructions for use.

### Tip

- Check the operation of all towing lights before departure.
- Make sure the towing ball is securely fixed.

#### I. Towing capacity

Maximum towing capacity (including all cargo and additional equipment) and vertical carrying weight of the towing hook shall not exceed the following values: Maximum towing capacity of the vehicle, maximum load bearing capacity of the towing hook:

Tire	Maximum towing capacity (maximum towing weight)	Maximum load capacity of the hook (maximum vertical weight of the trailer tongue)
20" , 21"	750 kg	75 kg

The hook load capacity is the downward force exerted by the trailer weight on the hitch mechanism. When driving a trailer with a C6 driver's license, the total mass must be less than (not equal to) 4,500 kg, including the mass of the trailer and the mass of the vehicle. Loading a large amount of equipment or cargo in a trailer reduces its towing weight, which also reduces the maximum towing capacity.

### Warning

- Do not allow the vehicle or towing trailer to exceed the maximum load capacity to avoid vehicle damage caused by accelerated wear and tear.
- Loading the vehicle beyond its maximum capacity will adversely affect its stability and braking performance, leading to loss of control and increased braking distances, and potentially causing

## 7. Driving

serious accidents.

- When calculating the load weight on the rear axle, keep in mind to add the load weight on the tow nose, the load in the vehicle luggage compartment, the weight on the roof rack and the weight of the passengers in the rear seats together.

### Tip

- Before buying a tow hook, ensure to check the size match to avoid installation problem.

### II. Tire pressure during towing

Adjust the tire pressure to accommodate the additional load during towing.

The technical allowable maximum mass on the rear axle during towing does not exceed 1,797 kg. Under these circumstances, the speed must not exceed 80 km/h, and the rear tire pressure must be at least 20 kPa to 30 kPa higher than the normal recommended tire pressure.

### Warning

- If there is a tire failure in the vehicle, do not attempt to tow a trailer. A temporary repaired tire cannot withstand the towing load. Towing with faulty or temporarily repaired tires can lead to tire failure and loss of vehicle stability.

### III. Operation before towing

The following operations must be performed before towing:

- Inflate the tires to the specified cold tire inflation pressure for towing.
- Understand and comply with all local legal and regulatory requirements for towing.
- Adjust the rearview mirror to ensure that there are no obvious blind spots.

Before towing, please confirm the following:

- The towing driver must hold a C6 driver's license.
- The vehicle must be level when connecting the towing device. If the front of the vehicle is upward inclined and the rear is downward inclined, make sure that it does not exceed the maximum towing capacity and tow hook bearing weight provided in the "Towing Capacity" table.
- All trailer components, accessories, and electrical connectors are in good condition and properly connected. Do not tow if there are any obvious problems.
- The trailer tongue is firmly connected with the tow ball device.
- All cargo is secured.
- The vehicle stoppers are available.
- The tow load is evenly distributed to ensure the trailer tongue weight is approximately 4% of the total trailer weight and does not exceed the maximum trailer tongue bearing weight provided in the "Towing Capacity" table.

### Warning

- Always make sure the cargo is secured in the trailer and will not move. Dynamic load movement may cause the vehicle to lose control, resulting in serious injury or death.
- The trailer tongue weight is approximately 4% of the total trailer weight and does not exceed the maximum trailer tongue bearing weight provided in the “Towing Capacity” table. An unbalanced load on the wheels or a heavier load at the rear may lead to loss of vehicle control.
- The towing weight shall not exceed the total weight of the vehicle, the maximum rear axle mass and the maximum trailer mass.
- After loading, the towing trailer should be parallel to the ground.

#### IV. Towing guidance

The vehicle is primarily designed for passenger transport. Towing a trailer will impose additional loads on the vehicle’s motor, transmission system, braking system, tires and suspension, significantly reducing the driving mileage. When it needs to tow a trailer, operate carefully and follow these guidelines:

- Reduce driving speed and avoid sudden maneuvering. When towing a trailer, compared to driving without a trailer, steering, stability, turning radius, stopping distance and braking performance are all different.
- Avoid sharp turns, as it may cause the trailer to touch the vehicle and cause damage. As trailer wheels are closer to the inside of the turn than the vehicle wheels, turn wider to prevent the trailer from hitting curbs, road signs, trees, or other objects.
- Stay at least twice as far away from the vehicle in front of you to increase the following distance. This helps avoid emergency braking. Sudden braking may cause skidding or bottom damage as well as loss of control.
- Regularly check whether the cargo is secure.
- Regularly check whether the trailer brakes are working properly.
- Avoid parking on slopes.
- Regularly confirm that all towing parts are firmly tightened.
- During towing, no personnel are allowed to ride in the trailer.
- Place heavy objects in the trailer as close to the axle as possible to reduce swaying interference during the towing.

#### V. Parking during towing

It is recommended to park the vehicle on a flat surface with a slope not exceeding 12%. If it is necessary to park on a slope, place wheel stoppers under the trailer wheels:

1. One person presses and holds the brake pedal.
2. Another person places the stoppers under the wheels on the downhill side of the vehicle's tires.



## 7. Driving

- When the stoppers are in place, release the brake pedal and ensure the stoppers can withstand the weight of the vehicle and trailer (if Autohold is not enabled).
- Put the vehicle in P gear and activate the electronic handbrake.

### Warning

- Always ensure that all trailer wheels are securely with stoppers when parking on a slope. Otherwise, it may lead to severe vehicle damage, personal injury or death.

### VI. Electrical connection

Trailers are equipped with taillights, brake lights, side indicators and turn signal lights. To power the trailer lighting system, the vehicle has a built-in 13-pin electrical connector installed in the middle of the rear bumper. The electrical connector can connect most of the trailer wire plugs. If the electrical connector of the towing truck (trailer) is a 7-pin electrical connector, you need to purchase an adapter.

Pin number	Function	Pin number	Function
1	Left turn signal light	8	Reverse light
2	Right fog light	9	No output
3	Pin 1-8 ground	10	12 V power output when the vehicle is awakened
4	Right turn signal light	11	Pin 10 ground
5	Right taillight	12	Interfaces reserved for future configuration
6	Brake light	13	Pin 9 ground
7	Left taillight		

### Warning

- Do not attempt to directly splice or use any other method to connect the trailer's wiring. Otherwise, it may damage the vehicle's electrical system and cause faults.

### Caution

- Before towing and during towing, check and ensure that all electrical connections are working properly, and all trailer lights are functioning correctly.
- Make sure that the trailer wires are not contacting with or dragged on the ground, and allow for turning space for the wires.

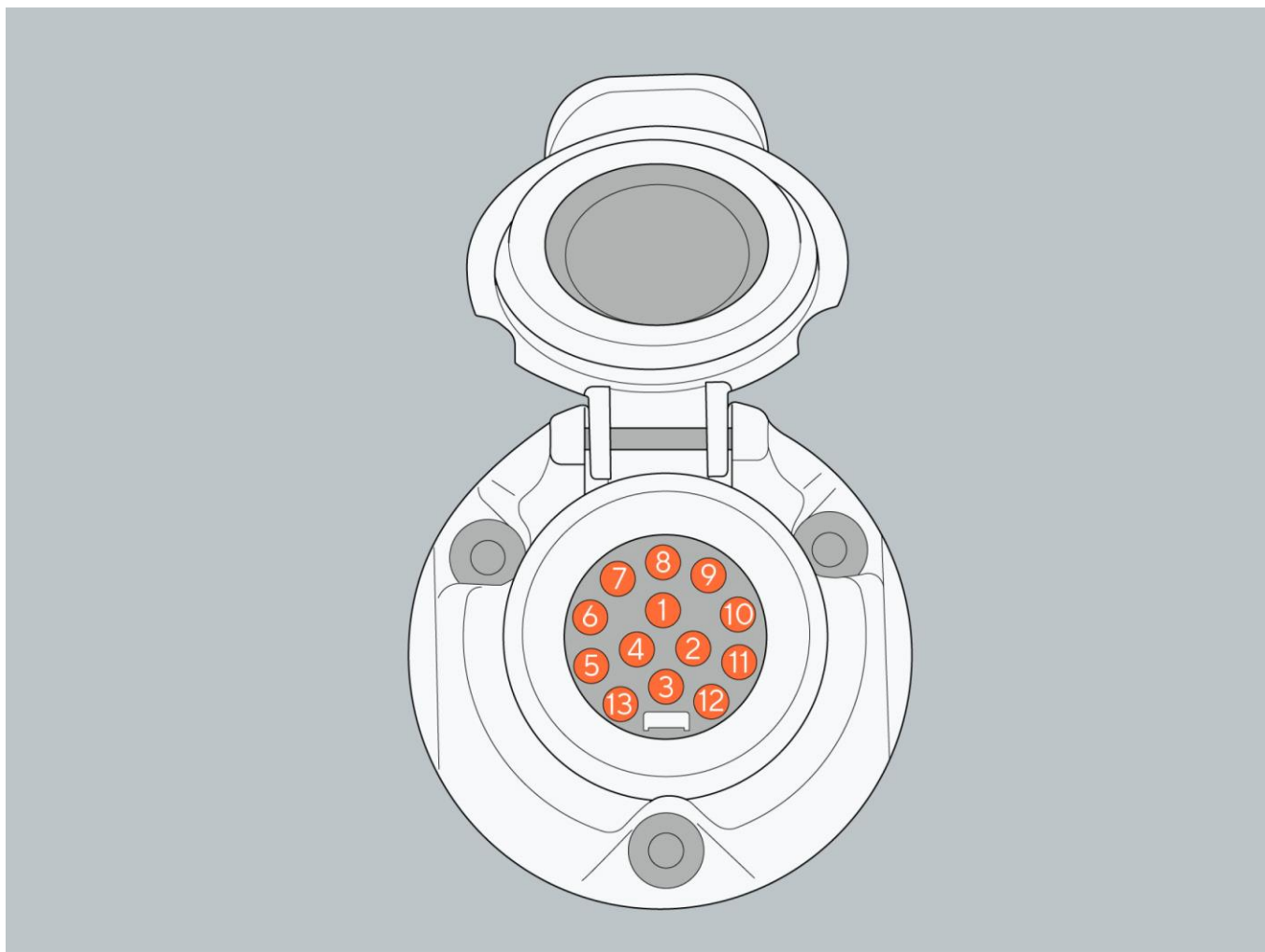

## 7. Driving

### 7.2 Driving specification

#### 7.2.1 Power mode switching

##### I. Vehicle power-on

“ON” mode: All vehicle electrical appliances are powered on and operational, but the vehicle cannot be started to drive. In the “OFF” mode, you can switch to this mode by opening any door with a valid remote key or Bluetooth key.

“READY” mode: The vehicle is in a drivable state. You can switch to this mode by pressing the brake pedal with a valid remote key or Bluetooth key.



Tip

- When the vehicle is started and in P gear, if the driver's side door is detected to be open and the driver leaves the seat, the vehicle will automatically switch from “READY” mode to “ON” mode.

##### II. Vehicle power-off

“OFF” mode: All vehicle electrical appliances are turned off. You can switch to this mode by closing all doors and locking the car.

## 7.2.2 Gearshift mechanism

The gearshift mechanism used in this vehicle is an electronic gearshift handle, which has 4 gear positions: P, R, N and D.

### I. Operate the shift handle

The vehicle's power is in the "READY" mode. Press the brake pedal. Hold the shift handle unlock button. Move the handle forward or backward to the specified position to switch gears.

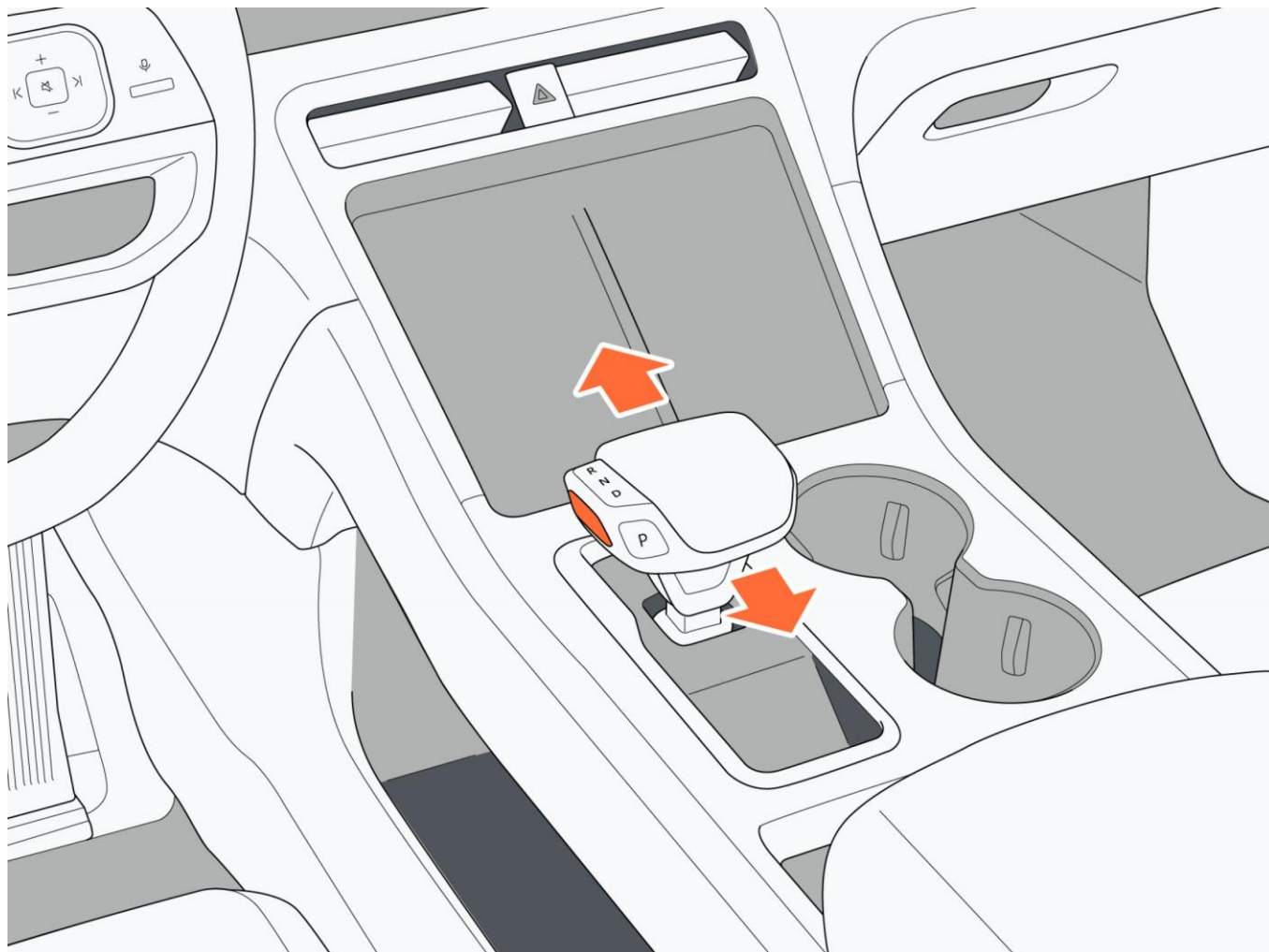

### II. Gear use

Gear	Function
P	Parking
R	Reverse
N	Neutral
D	Drive

### III. Gear switch

- P (Parking Gear): When the vehicle speed is below 5 km/h, press the P gear button on the shift handle, and the vehicle enters P gear.

## 7. Driving

- R (Reverse Gear): When the vehicle speed is below 5 km/h, press the brake pedal, hold the shift handle unlock button, and push the handle forward to R gear.
- N (Neutral Gear): When the vehicle speed is below 5 km/h, press the brake pedal, hold the shift handle unlock button, and push the handle to N gear.
- D (Drive Gear): When the vehicle speed is below 5 km/h, press the brake pedal, hold the shift handle unlock button, and push the handle to D gear.

### Warning

- During driving, if an emergency occurs (such as brake system failure), press and hold the P gear button to activate the dynamic parking function. The vehicle will decelerate within a certain range until it stops. Release the P gear before the vehicle stops, and the dynamic parking function will exit immediately.
- Ensure the vehicle is in P gear before the driver exiting the vehicle. Do not rely on the vehicle to shift to P gear, as this function may not work in all situations.
- If the vehicle cannot shift gears normally, contact the ROX Service Center in time.

### Tip

- If the driving speed is too high or the brake pedal is not pressed during shifting, the vehicle will not be able to shift gears.

### 7.2.3 Turn signal light control

Lane Change: Move the turn signal control lever up or down to position 1, and the turn signal light and the instrument panel turn indicator will flash three times.

Steering: Move the turn signal light control lever up or down to position 2, and the turn signal light and the instrument panel steering indicator will continuously flash. Again pull the turn signal lamp control lever up or down to position 1, and the turn signal light and the instrument panel turn signal indicator will turn off.

#### **i** Tip

- If the turn signal lamp flashes quickly, it indicates a fault with one of the vehicle's turn signal lights. Please go to the ROX Service Center for maintenance promptly.

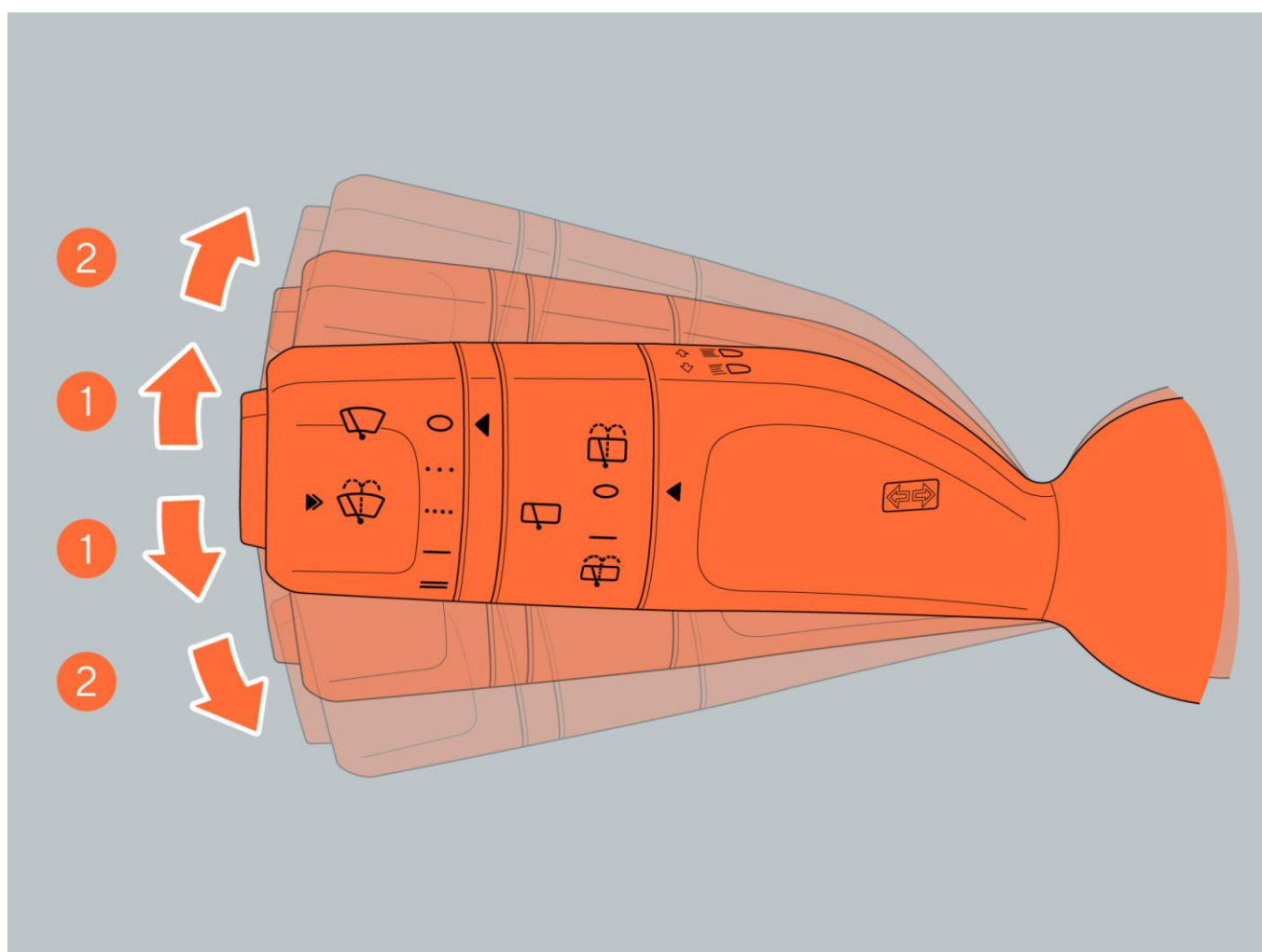

### 7.2.4 Low-speed pedestrian warning sound

The low-speed pedestrian warning sound is used to alert other road users (including pedestrians, bicycles, etc.). When the low-speed pedestrian warning sound is enabled, the vehicle automatically determines whether to send a warning sound based on the vehicle speed information.

Click "Vehicle Settings → Vehicle → Driving → Low-Speed Pedestrian Warning Sound" through the control screen to set the low-speed pedestrian warning sound: Off/Engine/Sci-Fi.

## 7. Driving

### Caution

- The temporary off function of the low-speed pedestrian warning sound can only be used when there are no other road users in a short distance, and it obviously does not need a warning sound for the surrounding environment.

### 7.2.5 Special road condition

Click “ROX Mode → Special Road Conditions” through the central control screen, and you can choose between two special road condition modes: “Snow and HDC” .

- Hill descent control: When the vehicle is going downhill, the hill descent control (HDC) system will automatically intervene. It can apply a certain braking force to the wheels to ensure the vehicle’s speed is stable during downhill driving.
- Snow Mode: Applicable to road surfaces that are wet and loose but do not sink.

### 7.2.6 Tire pressure monitoring system (TPMS)

The vehicle is equipped with a tire pressure monitoring system. It can detect tire pressure information and display the current tire pressure and temperature on the instrument panel. When the tire pressure is too high, too low, or the tire is overheated and rapidly flattening, the tire pressure monitoring system warning light will illuminate, and the instrument panel will display related text alerts. When the tire pressure warning light appears, please check whether the tire is normal immediately to avoid safety incidents. The following are common fault alarms and solutions:

- Low pressure alarm: Supplement tire pressure to the standard pressure value.
- High pressure alarm: Reduce the tire pressure to the standard pressure value.
- High temperature alarm: Stop driving and check tire pressure.
- Rapid deflation: Stop driving and check if the tire is damaged.

### Caution

- To enhance driving safety, if the tire pressure monitoring system is not functioning properly, contact the ROX Service Center promptly.

### Tip

- The tire pressure monitoring system may be affected by radio waves, which could limit or prevent its normal operation. You can correct the tire pressure information by driving the vehicle away from radio wave devices or changing the frequency that interferes with radio waves.
- After wheel rotation, tire replacement, or tire pressure sensor replacement, please drive to the ROX Service Center to have the tire pressure sensor recalibrated.

### 7.2.7 Electronically controlled adjustable suspension

The electronically controlled suspension system improves vehicle ride comfort and stability, reduces tire load variation, shortens braking distance, and minimizes body vertical vibration. This resolves the conflict between vehicle handling stability and comfort.

While the vehicle is stationary, you can customize the suspension adjustment mode by clicking “Vehicle Settings → Vehicle → Driving → Suspension Mode” through the control screen.

- Comfort mode: The damping force is relatively small, applicable to off-road and unpaved surfaces.
- Standard mode: The damping force is moderate, applicable to ordinary roads.
- Sport Mode: The damping force is relatively large, applicable to high-speed roads.
- ROX Mode: The damping force is moderate, releasing suspension travel, applicable to off-road and unpaved surfaces.
- Intelligent mode (if any): Intelligent mode can intelligently select the appropriate damping level based on road conditions and driving habits, which is suitable for all kinds of road.

### 7.2.8 Speed-sensitive variable electronic power steering

Click “Vehicle Settings → Vehicle → Driving → Steering Power” through the central control screen, and click the “Steering Power” icon to switch between the three steering modes of “Comfort, Standard, and Sport” (the default is standard mode).

- Comfort: The steering wheel has lighter force, applicable to driving on congested roads or urban areas.
- Standard: Applicable to general driving.
- Sport: The steering wheel has heavier force, applicable to intense driving, high-speed, or rainy and snowy weather.

#### Warning

- Do not adjust the steering assist mode while driving, as it may distract the driver’s attention from the road conditions and lead to an accident.

## 7.3. Driving essentials

### 7.3.1 Driving essentials for extended range vehicles

When the vehicle is in use, make sure to comply with the specified driving regulations to ensure safe driving.

#### I. Wet and slippery road surface

When driving on wet and slippery roads, be sure to reduce speed and drive with caution.

Emergency braking, sudden acceleration, or quick steering on wet and slippery roads can cause the tires to skid, making it difficult to control the vehicle and increase the risk of accidents.

#### II. Driving through water



# 7. Driving

## 1. When it is necessary to drive through water

- Before driving through water, please enable the wading mode in the ROX Mode. Analyze the road conditions and confirm the depth of the water. The water depth must not exceed the lower edge of the vehicle body. When the water depth or road conditions are unknown, the vehicle must detour. It is forbidden to forcefully pass through.
- While driving through water, do not stop, and maintain a low speed (the speed must not exceed 10 km/h).
- When passing through intersections or intersecting with other vehicles, drive carefully to avoid splashing water over the front grille.

## 2. After driving through water

- Press the brake pedal lightly several times to clear residual water from the brake disc and ensure the braking system is working properly.
- Check the vehicle's horn, all lights, etc.
- Please go to the ROX Service Center for a regular check-up as soon as possible, as water may enter the transmission system components and dilute the lubricant, potentially causing system failures during wading.

### Warning

- Do not drive on a road section where the depth of stagnant water is unknown. This can avoid damaging electrical components or the range extender.
- Do not drive through water for extended periods to avoid damaging the vehicle.
- Do not drive on saltwater-filled sections to avoid corrosion of the vehicle body.
- After the vehicle has bottomed out or been submerged, go to the ROX Service Center for inspection to avoid personal injury or vehicle damage due to mechanical damage to the power battery or high-voltage safety incidents.

## III. Off-road escape

There is a risk of vehicle damage during driving if:

- The vehicle becomes stuck, for example, on a high curb or unpaved road.
- Drive over obstacles, such as curb, speed bump, or pothole, at a high speed.
- A heavy object hits the underbody or chassis component.

In such cases, the body, underbody, chassis components, wheels, or tires may suffer from unseen damage. Components suffered such damage may malfunction unexpectedly or fail to withstand pressure as expected in an accident.

If the underbody guard is damaged, flammable materials such as leaves, grass, or twigs may accumulate between the underbody and the underbody guard. If these materials come into contact with the hot parts of the exhaust system, a fire may be caused.

In such cases, please go to the ROX Service Center for inspection and repair immediately. If you notice a decrease in driving safety while continuing your journey, please immediately pull over to a safe location and pay attention to the road and traffic conditions. In this case, please consult the ROX Service Center.

When driving off-road, sand, mud, and water or oil-water mixtures may enter the brake. This can result in weakened braking or complete failure of braking functions due to increased wear. The braking characteristics will vary depending on the material that gets trapped in the brake. After off-road driving, the brake should be cleaned. If you notice a reduction in braking effectiveness or hear a loud noise, please go to the Extreme Stone Automotive Service Center to check the braking system immediately. Adjust your driving style according to the different braking characteristics.

Off-road driving increases the likelihood of vehicle damage, which may lead to failures of assembly or system. Please go to the ROX Service Center to repair any damaged parts of the vehicle immediately. Adjust your driving style according to the terrain conditions. Please drive with caution.

#### IV. Safe braking

When the vehicle needs emergency braking, firmly press the brake pedal.

#### V. Long downhill

When driving on a long downhill, you can enable HDC in the ROX Mode or set the regenerative braking to its maximum level. If you hold the brake pedal down for a long time, even with light pressure, it can cause the braking system to overheat, wear out, or even fail, potentially leading to an accident.

Do not rely on the vehicle's inertia to coast in N gear or when the powertrain is off, as this can result in a lack of braking and steering assistance, increasing the risk of an accident.

#### VI. Driving in rainy day

When driving in the rain, there will often be poor visibility, fogging on the windows, and slippery road. Please drive with caution.

Emergency braking, sudden acceleration, or quick steering on wet and slippery roads can cause the tires to skid, making it difficult to control the vehicle and increase the risk of accidents. When driving in a rainy day, water film is easy to form between the tire and the road surface. At this time, the tire is easy to lose grip. Please drive at a reduced speed.

#### VII. Driving mileage

When you want to maximize your driving mileage, please keep the following points in mind:

- Energy recovery: Adjust the regenerative braking level to a higher setting to recover more electrical energy during coasting.
- Drive smoothly to avoid sudden acceleration and deceleration.
- Traffic Congestion: Try to avoid driving on congested roads. Stop-and-go driving can accelerate energy consumption.

## 7. Driving

- Air Conditioning: Use the air conditioning only when necessary. When using it, close the windows to reduce resistance. This helps reduce energy consumption and increase the mileage.
- Tire pressure: Ensure that tire pressure is within the normal mileage. Lower tire pressure increases rolling resistance, which will increase energy consumption.
- High-speed driving: Maintain a stable speed and try to apply the brakes lightly in advance when needed, which maximizes energy recovery.
- Regular maintenance: Regular maintenance is essential to keep the vehicle in optimal condition. A dirty air filter, spark plugs, engine oil, etc., can reduce the performance of the range extender.

### VIII. Avoid damage to vehicle components

Do not keep the steering wheel in the extreme position for a long time, as this may damage the steering motor. When driving on a bumpy road, try to maintain a lower speed to avoid damaging the wheels or vehicle underbody.

#### Warning

- Do not drive over park near flammable materials. As the exhaust system and exhaust gases can be very hot, and any flammable materials in the vicinity could potentially cause a fire.

### 7.3.2 Driving essentials

Before driving your vehicle in winter, make the necessary preparations and inspections and drive your vehicle in a manner suitable for the main winter weather conditions.

#### I. Vehicle preparation in winter

- Use oil and fluid suitable for winter temperatures (engine oil, coolant, windshield washing fluid).
- When driving on icy or snowy roads, fit snow tires or install tire chains on the wheels.

#### II. Preparation before driving

- If the windows or windshield wipers are frozen, do not operate the windshield wipers. Apply warm water to melt the frozen part and wipe it clean immediately to avoid refreezing.
- Clean any ice or snow that may have accumulated on the windows, windshield, roof, and chassis of the vehicle.
- Remove any mud or snow from your shoes before entering the vehicle.

#### III. Driving on ice and snow road

- Maintain a safe distance from the vehicle ahead and adjust your speed appropriately for different road conditions to avoid sudden acceleration or deceleration.
- When turning, slow down in advance, turn the steering wheel gently, avoid sharply turning the steering wheel, and pass through at a steady speed.

#### IV. Parking

On ice and snow surfaces, try to park the vehicle on a flat road and engage the parking gear with the electronic handbrake activated. If necessary, place wheel stoppers.

#### V. Replacing winter tires

When driving on icy and snowy roads in winter, replace all four tires with winter tires simultaneously. The four tires must be of the same size, brand, construction and tread pattern.

### VI. Snow chain

This vehicle is not equipped with snow chains. You may buy them yourself. When using snow chains, please note the following:

- Inappropriate snow chains can damage the vehicle's tires, wheels, and braking system. Please carefully check the specifications of the original tires and the relevant usage instructions of the snow chain manufacturer.
- The thickness of the snow chains should not exceed 7 mm.
- After installing snow chains, the speed should not exceed 50 km/h, or the lower speed limit allowed by the snow chain manufacturer.
- When driving on snow-free roads, please remove the snow chains to avoid excessive wear on the wheels or snow chains.

### Warning

- Do not exceed the speed limit on the road or the speed limit specified for the winter tires used.
- Do not drive on bumpy or pothole roads.
- Do not use chains on snow-free roads.
- Do not use tires that do not match the specified specifications.
- Do not leave the tire pressure outside the recommended range.
- Do not exceed the speed limit specified for the snow chains used.
- Do not perform sudden acceleration, steering, braking or shifting operations.

### 7.3.3 Precautions for extended range vehicles

#### I. Precautions for power battery

If the power battery level is too low, the vehicle can only generate power through the range extender. At this time, its performance will be reduced. Therefore, it is necessary to reserve some energy to cope with more severe driving conditions (such as overtaking, intense driving, etc.).

#### II. Exhaust system

The vehicle's exhaust system can produce high temperatures. Do not remove the heat insulating plate in this area. When the range extender is activated, flammable materials such as leaves and dry grass should not come into direct contact with the high-temperature exhaust system, as this could ignite these items and cause a fire, leading to serious personal injury and vehicle damage.

#### III. Condensation during parking vehicle

When parking the vehicle after using the air conditioning, water marks on the vehicle's parking location are normal condensed water from the air conditioning.

#### IV. Driving in maximum speed

## 7. Driving

When driving downhill, the maximum speed may trigger an overspeed fault of the drive motor. This can cause irreversible damage to the drive motor. Please keep the speed within an appropriate range.

### Warning

- Please drive at the speed limit specified by national road regulations. Failure to comply with traffic rules may result in serious traffic accidents or even casualties.

## 7.4 ROX Mode

### 7.4.1 ROX Mode

#### I. ROX Mode

The ROX Mode includes six modes: snow, mud, rock, sand, wading and highway mode. To enter the ROX Mode interface, click the “ROX Mode” icon at the bottom of the central control screen. Only one mode can be enabled at a time (when the snow mode is enabled, you enable the mud mode, and the snow mode will automatically exit).

#### II. Mode introduction

Highway: Highway mode is primarily suitable for vehicles driving on paved surfaces such as cement and asphalt.

##### 1. Entry and exit

- Entry mode: Every time the vehicle is powered on, the default mode is road mode or the other mode exits and automatically enters the road mode.
- Exit mode: When switching from road mode to snow, mud, rock, wading and sandy mode, the road mode will automatically exit. If the APA is in operation, the mode cannot be switched.

##### 2. Mode setting

- After entering the highway mode, you can set the power mode (sport/standard/energy-saving/sport+), suspension mode (comfort/standard/sport/ROX/ intelligent(if any)), power steering (comfort/standard/sport), energy recovery (low/medium/high), and energy mode (electric priority/fuel priority/hybrid) in the mode interface.

##### 3. Traffic detection

Click the “Traffic Detection” button to enter the detection interface. You can select “height detection, width detection and slope detection” in the interface.

### Tip

- If you perform another detection or use other detection method and do not return to the page, it will display a new result, replacing the original result.
- During the detection process, click Return to enter the detection page again. It will not display the detection result.
- When using height detection, the speed must not exceed 60 km/h. The speed must not exceed 30 km/h for width detection and slope detection.

### 4. AVM

When the vehicle speed is below 20 km/h, the central control screen displays the current left/right front wheel hub view and the front view of the vehicle.

Snow mode: The snow mode is mainly used for driving on snowy roads, uncompacted loose snow surfaces, and other road conditions (road mode is recommended for compacted snow surfaces and ice surfaces).

#### Warning

- When the snow drift mode is enabled, the vehicle will automatically turn off the ESP. It may cause a risk of instability. It is necessary to drive in a specific area.

#### Caution

- When running snow drift, the forward-facing collision warning/lane departure assist/navigation assist/adaptive cruise control/lane centering assist functions will not be activated. Please drive with caution.
- When the speed exceeds 75 km/h in snow drift mode, the vehicle stability system is activated, and the snow mode automatically exits.

Mud mode: The mud mode is primarily aimed at driving on roads with deeper, soft, muddy conditions, soft ruts.

Rock mode: The rock mode is primarily aimed at driving on roads with large boulders, rocky terrain, undulating mountain roads, and steep slopes.

#### Caution

- If the speed is above 60 km/h, the rock mode cannot be activated.

Sand mode: The sand mode is primarily aimed at driving on roads where the wheels are prone to sinking, dry soft sand, sand dunes, deserts.

Wading mode: The wading mode is primarily aimed at driving on roads such as rivers, streams, riverbeds that may have pebbles, wet mud, and aquatic plants.

#### Caution

- When the body angle exceeds 15°, the rearview mirror is folded, the speed exceeds 15 km/h, or any front passenger door is open, the wading detection is suspended.

### III. Off-road cruise

1. Off-road cruise: After entering the mode, click to enable "Off-Road Cruise". The system judges the current speed when entering:

- When the speed is above 17 km/h, the off-road cruise function cannot be enabled.

## 7. Driving

- When the speed is between 5 km/h and 17 km/h, the off-road cruise function is enabled. The current speed is set as the driving speed by default, with the off-road cruise icon illuminated on the instrument panel.
- When the speed is between 0 km/h and 5 km/h, the off-road cruise function is enabled. The current speed 5 km/h is set as the driving speed by default, with the off-road cruise icon illuminated on the instrument panel.

### 2. Adjustment of off-road cruise speed

- Pull the right side of the steering wheel to the up position once to the first gear, and the current speed increases by 1 km/h. Pull the right side of the steering wheel to the up position once to the second gear, and the current speed increases by +5 km/h.
- Pull the right side of the steering wheel to the down position once to the first gear, and the current speed decreases by 1 km/h. Pull the right side of the steering wheel to the down position once to the second gear, and the current speed decreases by 5 km/h.

### 3. Page information and functions

- Tire pressure: Display the tire pressure values of four wheels.
- Transparent chassis: Display the 2D/3D chassis of the vehicle.
- Pitch angle: For the current pitch angle of the vehicle, 0° is horizontal, the front of the vehicle is up by 1~90°, and the front of the vehicle is down by 1~90°.
- Roll angle: For the current roll angle of the vehicle, 0° is horizontal, the vehicle tilts to the left by 1~90°, and the vehicle tilts to the right by 1~90°.
- Output torque (front/rear): The percentage of torque the vehicle is able to output.
- Compass: The direction the front of the vehicle is pointing to, which changes as the direction of the front of the vehicle. The compass shows eight directions: east/south/west/north/northeast/northwest/southeast/southwest.
- Altitude: The altitude of the vehicle's current location (GPS point).

### 4. Automatic exit from off-road cruise

- When the electronic handbrake is activated, the off-road cruise mode automatically exits.
- System is abnormal.
- The driver leaves the driver's seat or the driver unbuckles the seat belt.
- The gear is switched to a non-D gear.
- The throttle opening exceeds the set value.
- The vehicle speed is greater than or equal to 60 km/h.

## 7.5 Operation of light and wiper

### 7.5.1 Exterior light switch

#### I. Turn off external light

Click “Vehicle Settings → Vehicle → Lights” on the central control screen to set the vehicle lights. Click the “Close” icon to turn off all external lights.

### II. Turn on the position light

Click the “Position Light” icon to turn on the position light. When the position light is turned on, the position light and license plate light will be on.

### III. Turn on low beam

Click the “low beam” icon to turn on the low beam, and the low beam indicator and position indicator on the instrument screen are lit.

### IV. Turn on automatic mode

When the vehicle’s power is in non- “OFF” mode, the external light automatic mode is turned on by default. You can also manually turn on the external light automatic mode by clicking the “Auto” icon.

In the automatic mode, the low beam and position lights are automatically controlled to turn on and off based on the light level of the environment.

### Caution

- In low visibility conditions, it may affect the automatic mode. Please manually control the lights according to the actual road conditions.

### V. Adjust the low beam

The vehicle is equipped with a low beam height adjustment function. When the low beams are on, the driver adjusts the low beam height according to the correct driving posture.

### VI. Welcome light

Click the “Approach Welcome” icon to turn on the welcome function. When you approach/leave the vehicle, the welcome light on the door handle will automatically light up/off.

### VII. Follow me home

Click the “Follow Me Home” icon to enable the Follow Me Home function. After locking the vehicle, the low beams and position lights can be delayed in lighting time. You can set the delay time for turning off in the Follow Me Home interface.

### Tip

- When the vehicle’s rain and sunlight sensor detects that it is daytime, the Follow Me Home function will not be activated.

## 7.5.2 Adjust the low beam height

The vehicle is equipped with a low beam height adjustment function. When adjusting the low beam height, the vehicle’s power is in non- “OFF” mode. Click “Vehicle Settings → Vehicle → Lights → Low Beam Light Height” icon on the central control screen to select from low/medium/high gears. The driver can adjust the lights to the best position according to the correct driving habits.



## 7. Driving

### 7.5.3 Automatic high beam

#### I. Automatic high beam

When the vehicle's power is in the "READY" mode, the low beams are on and the light gear is in "AUTO", the low beams will automatically switch to high beam when the lights of oncoming vehicles, the tail lights of preceding vehicles, or other light sources are not continuously detected. To turn off the high beams, you can switch the light gear to non- "AUTO", or when the vehicle's power is not in the "READY" mode, and the high beams will turn off. The automatic high beam is turned on by default. You can turn off the automatic high beam function by clicking "Vehicle Settings → Vehicle → Lights → Automatic High Beam" through the central control screen.

#### II. Overtaking light

Turn the left side control lever on the steering wheel twice to alert the vehicle ahead to yield.

### 7.5.4 Automatic low beam

When the vehicle's power is in non- "OFF" mode and the light gear is in "Auto", the vehicle will automatically turn on or off the low beams and position lights based on the current brightness (such as in a dimly lit underground parking garage). The low beams and position lights can be manually turned off through the central control screen.



Tip

- To prevent the driver from forgetting to turn on the headlamps during driving at night, when the vehicle's power switches from "OFF" to "ON" mode, the vehicle will automatically switch the light gear to auto mode.

### 7.5.5 Brake light

The brake lights turn on when the brake pedal is pressed and turn off when released; when the vehicle control system intervenes in the vehicle's braking, the brake lights will also turn on.

When the vehicle triggers an emergency brake, the hazard warning lights flash while the brake lights turn on. When the vehicle speed drops to a certain value, the hazard warning lights stop flashing and the brake lights turn off.

### 7.5.6 Reverse light

When the gear is shifted to R, the reverse lights turn on. When the gear is shifted out of R, the reverse lights turn off.

### 7.5.7 Fog light switch

Click the “rear fog light” icon through the central control screen. After clicking the icon to turn on the rear fog light, the instrument screen will display the rear fog light icon, and click again to turn off the rear fog light.

#### Tip

- When using the rear fog lights, you need to turn on the low beams first.
- When the vehicle detects smog, it will automatically turn on the rear fog lights. You can manually turn off the rear fog lights.

### 7.5.8 Windshield wiper and washer

I. Front wiper control lever

S/N	Name
1	Off
2	Automatic low speed sensitive gear
3	Automatic high speed sensitive gear
4	Manual low speed gear
5	Manual high speed gear

## 7. Driving

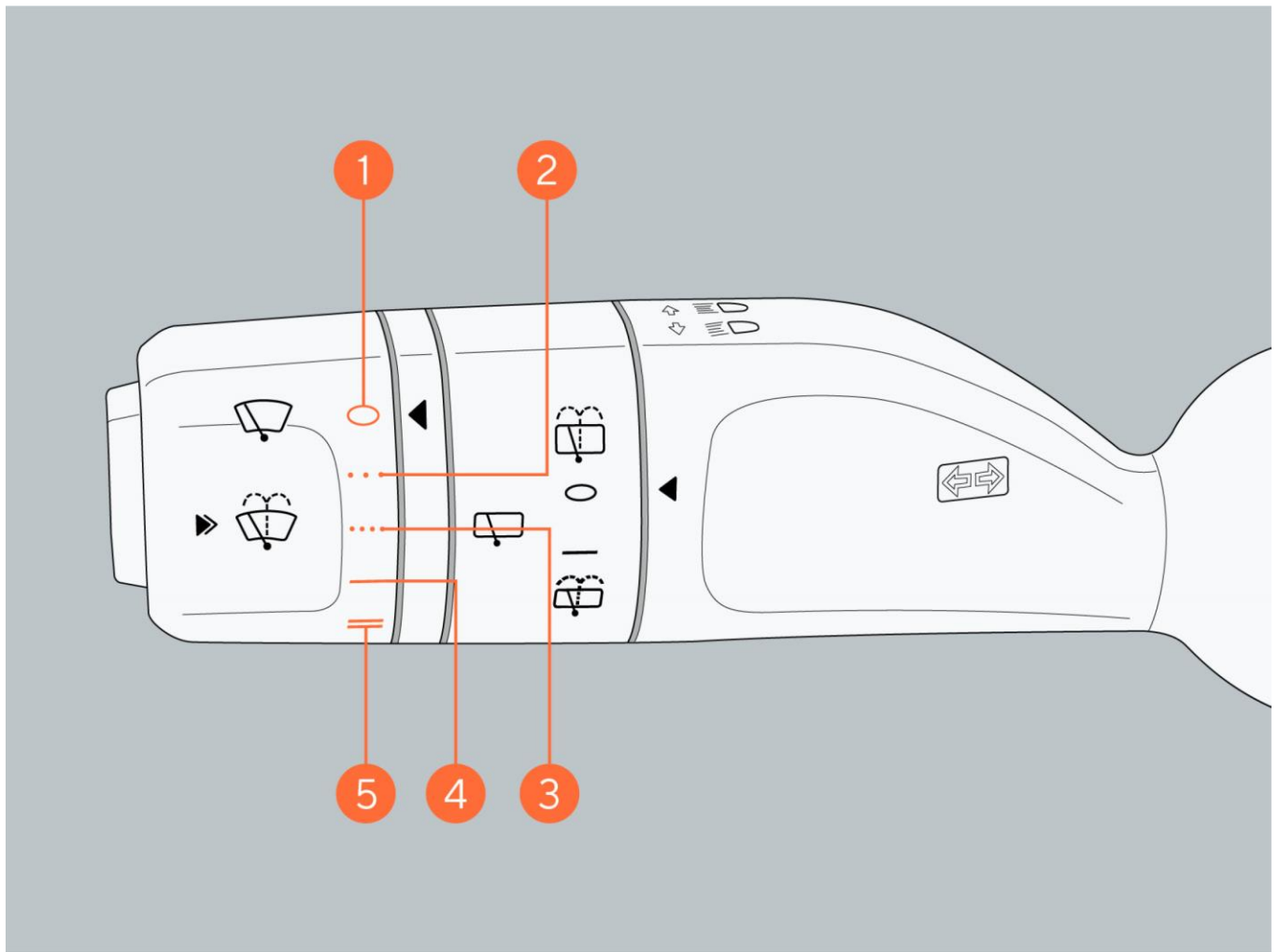

### II. Manual wiper

Gently press the wiper wash button, and the wiper will automatically sweep once. Deeply press it to activate the wash function, and the wiper will automatically sweep once.

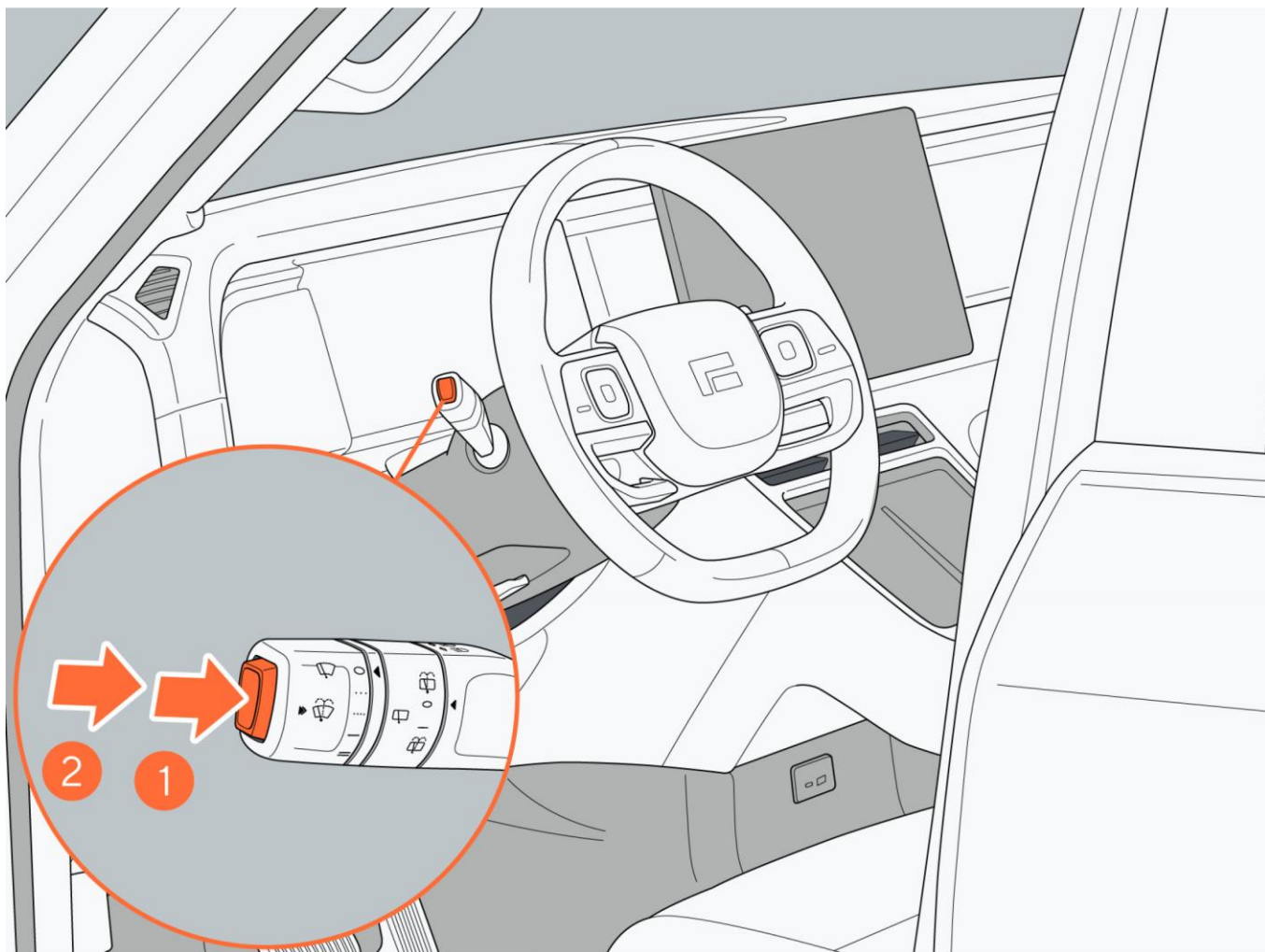

## 7. Driving

### III. Automatic wiper

After the vehicle starts, if the wiper control lever is in the automatic low speed sensitive mode or the automatic high speed sensitive mode, the sensor will automatically adjust the sweeping frequency based on the amount of rain. The automatic high speed sensitive mode sweeps faster and more frequently than the automatic low speed sensitive mode.

#### Warning

- Before turning on the windshield wiper, please thoroughly clean the snow and ice on the windshield.
- Avoid turning on the wiper when the windshield is dry or there is no washer fluid in the wash pot, as this may damage the wiper blade or the windshield.

#### Caution

- When the ambient temperature is below 0°C, the vehicle starts, and the wiper is in automatic mode, the wiper enters a protective mode. It exits the protective mode when the vehicle speed is greater than 5 km/h.

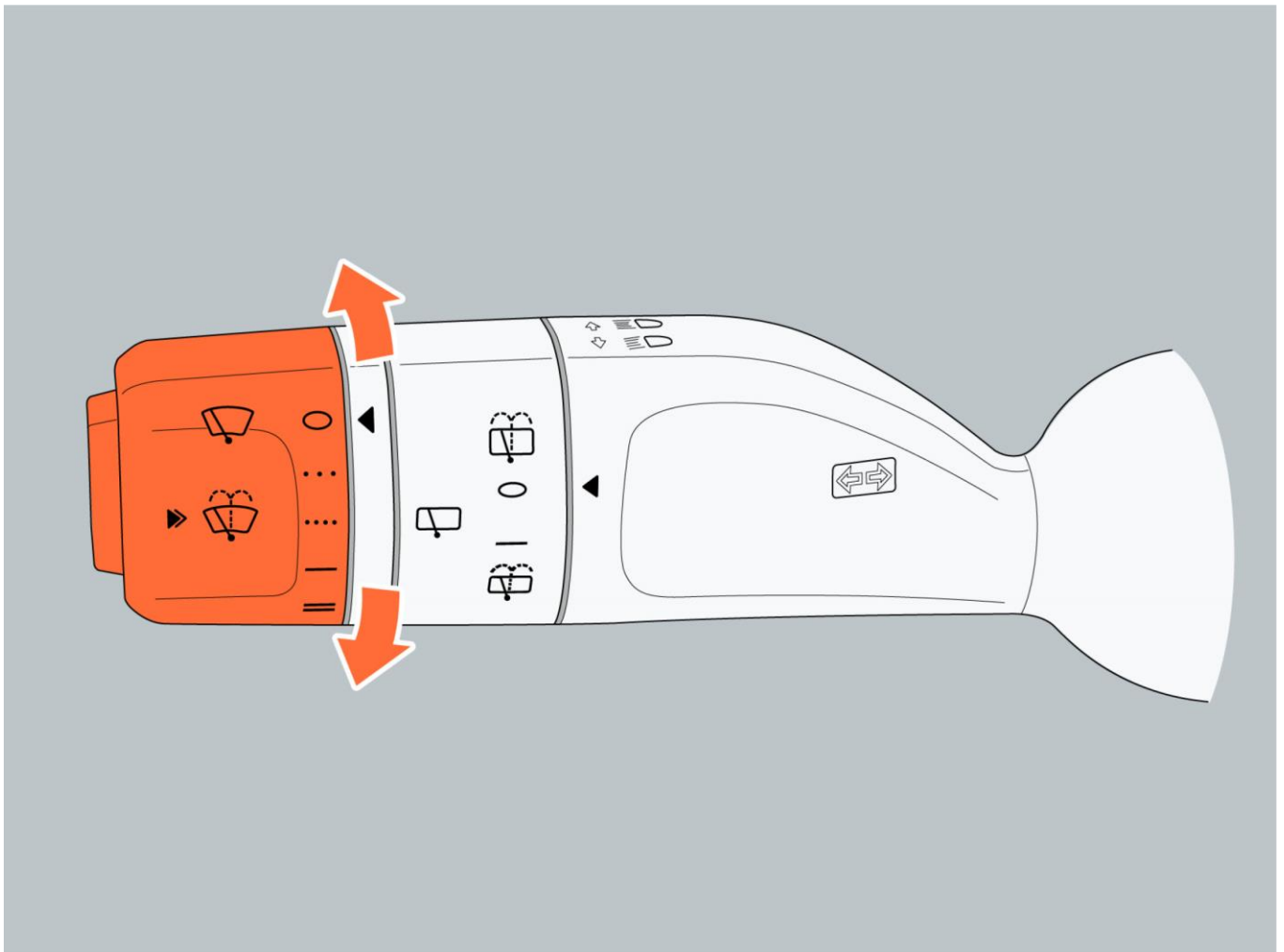

### 7.5.9 Rear window wiper and washer

#### I. Rear wiper control lever

S/N	Name
1	Turn off rear window wiper
2	Turn on rear window wiper

After the vehicle is started, turn the rear window wiper switch to turn on/off the rear window wiper. Turn the rear window wiper switch forward to activate the rear window glass washing function. When the front wiper is turned on, the vehicle enters R gear. If the rear wiper is not turned on manually, the rear wiper will automatically sweep.

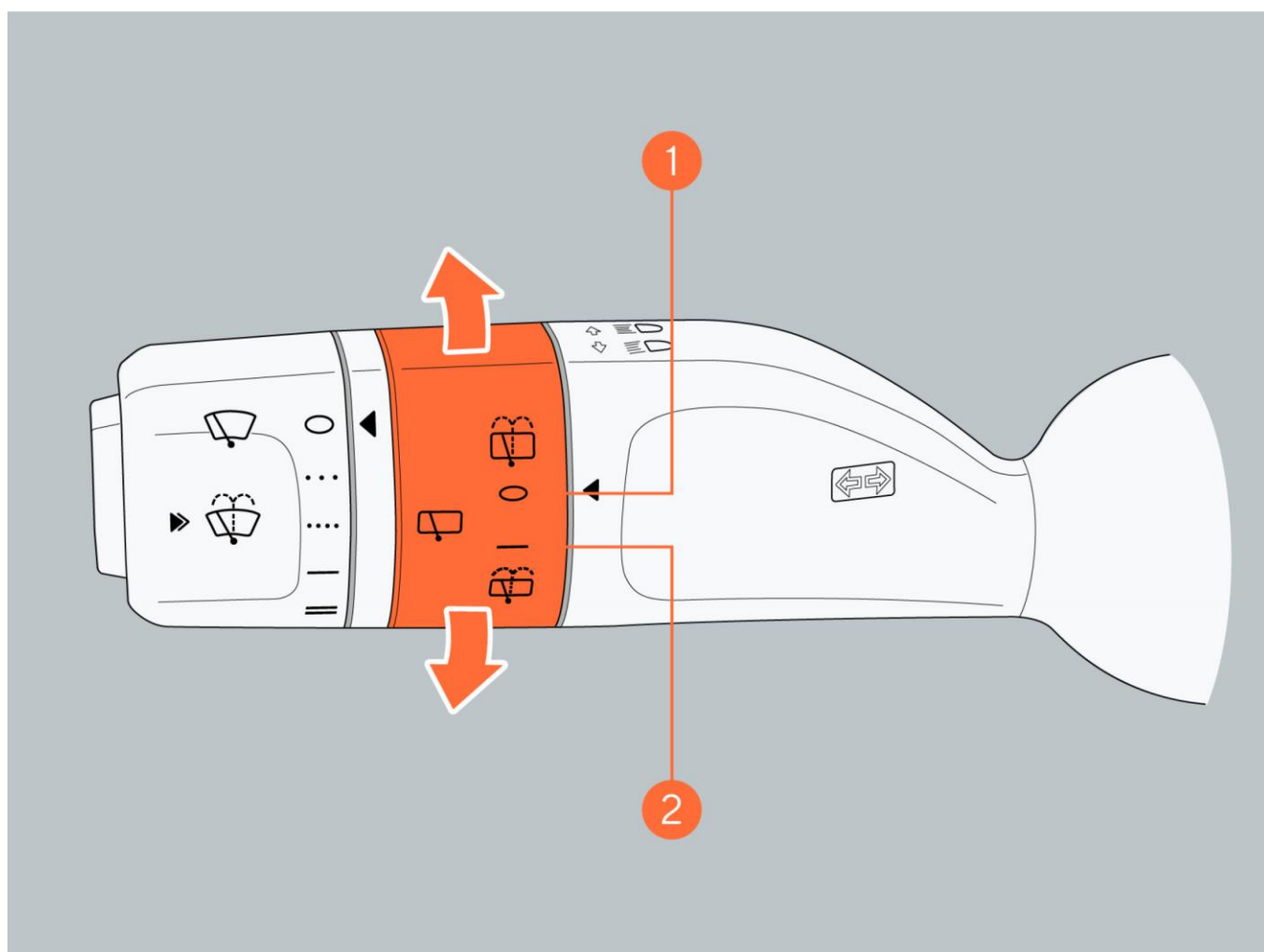

## 7.6 Driving assist system

### 7.6.1 Driver monitor system

Driver monitor system (this function is applicable to some models, subject to the actual vehicle)

During driving, the vehicle senses the driver's attention state through the camera in the cabin. When the system detects that the driver's attention is diverted, the system will send an alarm message to remind the driver to maintain attention.

# 7. Driving

## I. Activate/deactivate

You can enable or disable the driver monitor system by clicking “Vehicle Settings → Intelligent Driving → Driving Reminder → Driver State Detection” through the central control screen.

## II. Prompt information

When the vehicle detects that the driver is fatigued or distracted, it will remind the driver through text and broadcast. 15 minutes later, if it detects the driver’s fatigue or distraction again, the vehicle will remind the driver through text and broadcast and sound an alarm. When the system perceives that the driver has not regained attention for a long time, it will remind the driver through text and voice and steering wheel vibration, and continue to sound an alarm.

## III. Function limitation

The system may not be able to detect fatigue driving or driving distraction, leading to the inability to issue corresponding warnings and some functions being unavailable when:

- In a dimly lit scene.
- Under direct light interference.
- The camera in the cabin is damaged or obstructed by items.
- The driver’s complete facial or eye features are not detected.

### Caution

- The driver monitor system is a driving assist system and cannot work in all scenarios or conditions. Drivers should ensure safe driving.
- When an attention warning appears, the driver should adjust the driving state promptly or stop and rest as soon as possible.

## 7.6.2 Adaptive cruise control

Adaptive Cruise Control (ACC) senses the speed of the vehicle ahead through the forward-facing sensors, controls the vehicle to follow the vehicle ahead at a set speed and time limit, and automatically adjusting the speed by accelerating or decelerating. When ACC is activated, it can follow the vehicle ahead until the vehicle stops. If the vehicle ahead leaves in a short time, it can automatically start to follow. If the vehicle ahead parks for too long, the electronic handbrake will automatically engage, and the function will exit.

ACC is mainly suitable for dry and smooth standardized long straight roads, such as highways, urban expressways, highways, long straight trunk roads, etc.

### I. Adaptive cruise activation

When ACC meets the following conditions, a gray icon indicating that ACC can be activated appears on the instrument panel. By pulling the right side lever on the steering wheel inward, you can activate ACC function:

- The front view camera and millimeter-wave radar functions are normal, with clear vision.
- The driver’s seat belt is fastened.
- All doors are closed.

- The vehicle is in D gear.
- The driver does not press the brake pedal.
- The speed does not exceed 130 km/h.

After activating ACC, when there is no vehicle ahead, the ACC applicable speed range is 30~130 km/h. When there is a vehicle ahead, the ACC applicable speed range is 0~130 km/h. When the vehicle speed is below 30 km/h and the function is activated, set 30 km/h as the cruise speed. When the vehicle speed is above 30 km/h and the function is activated, set the current speed as the cruise speed.

### **i** Tip

- When applying the ACC, you can briefly press the accelerator pedal to operate the vehicle in a short time. At this point, the ACC will no longer follow the vehicle ahead. When you release the accelerator pedal, the system will control the vehicle to return to the cruise speed.

## II. Adaptive cruise operation

Activate, set, and exit operations of adaptive cruise by pulling the right lever of the steering wheel:

- Pull inward once to activate the adaptive cruise function.
- Pull outward once to exit the adaptive cruise function.
- Pull up once to increase cruising speed or restore cruising speed.
- Pull down once to reduce the cruising speed.

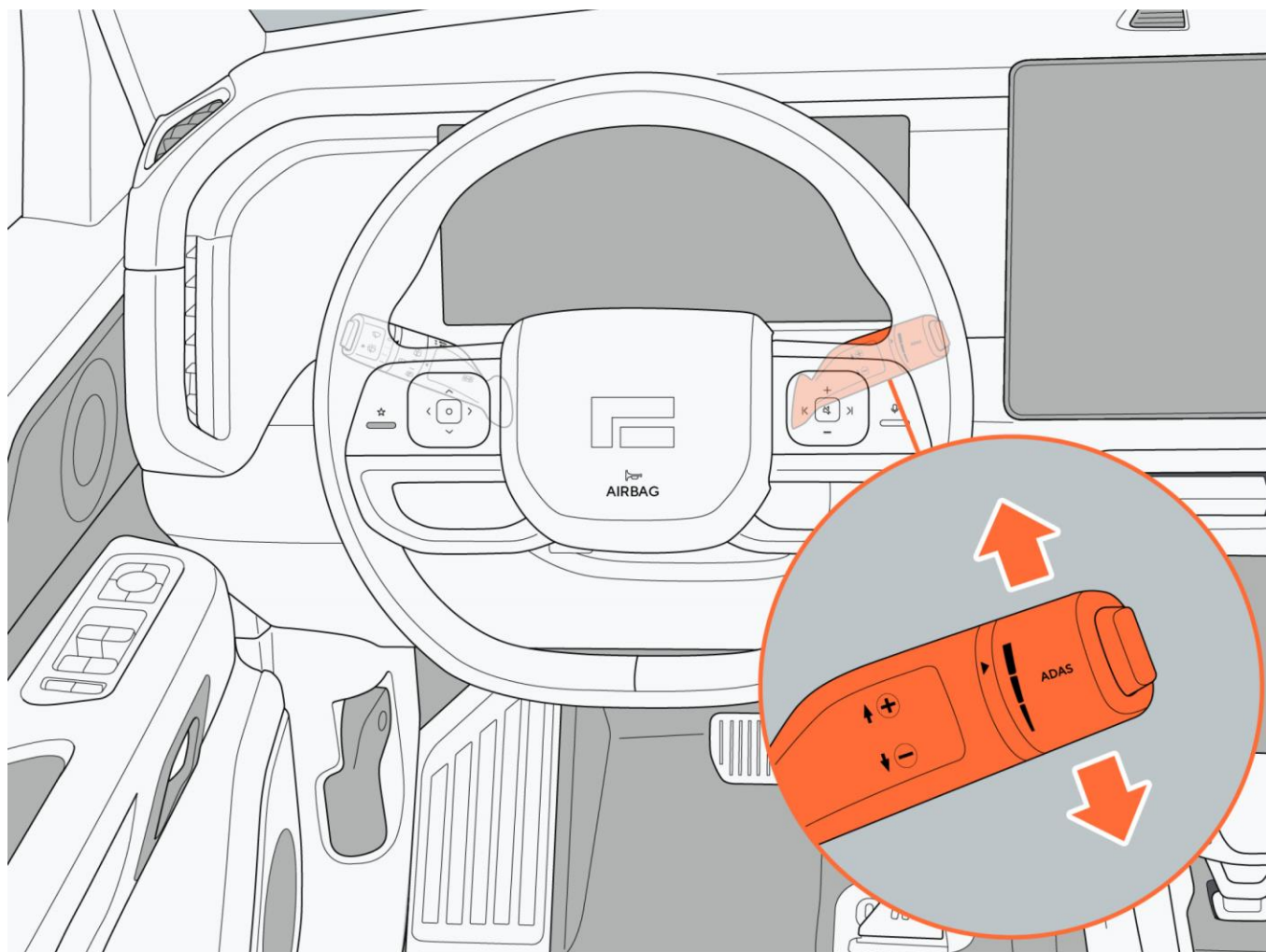



## 7. Driving

- Turn outward to reduce the follow-up time headway.
- Turn inward to increase the follow-up time headway.

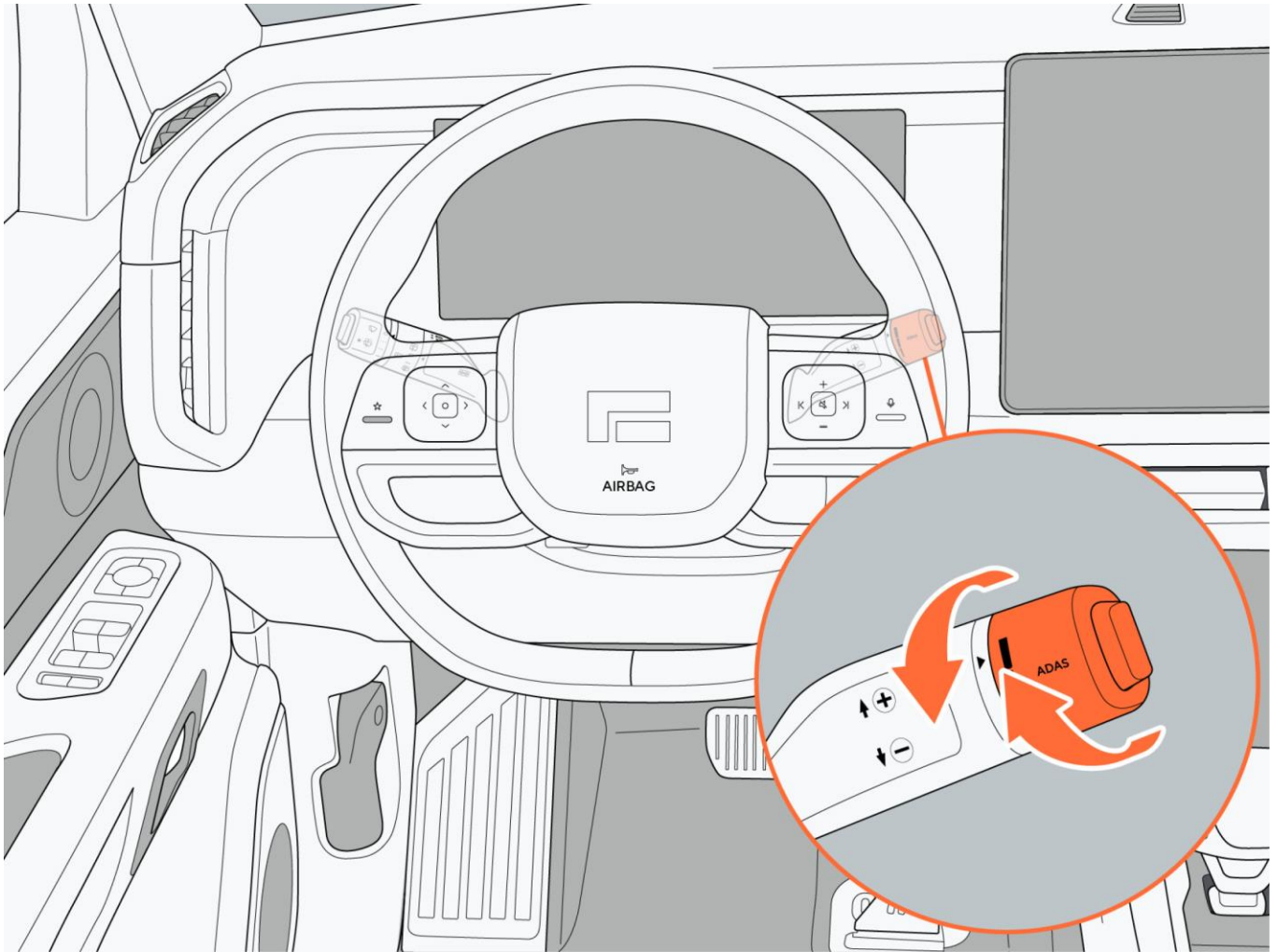

### III. Exit adaptive cruise

Push the lever on the right side of the steering wheel outward once or press the brake pedal to exit ACC, and the adaptive icon on the instrument panel will turn off.

#### **i** Tip

- If the vehicle follows for more than 5 min, the ACC will exit.
- After the ACC exits, the vehicle may slow down due to kinetic energy recovery braking and no longer maintain a set distance from the vehicle in front.

### IV. Following and starting

**Following:** In the following cruise state, the vehicle automatically adjusts its speed and distance based on the speed of the vehicle in front. If the vehicle in front slows down and stops, the vehicle will also brake automatically until it stops.

**Starting:** If the following vehicle in front starts within 1 min, the vehicle will automatically follow. If the following vehicle in front starts between 1 and 5 min, the vehicle will prompt the driver to lightly press the accelerator pedal to confirm following. If the following vehicle in front starts after more than 5 min, the vehicle will engage the electronic parking brake and exit the ACC.

 **Warning**

- In some cases, the ACC may not detect traffic participants around the vehicle, or the perception is ineffective or untimely due to interference factors. Therefore, when the vehicle follows and starts, you need to always pay attention to the traffic conditions and the surrounding road environment to avoid collisions.

## V. Adjust cruise speed

After activating ACC:

- Push the lever on the right side of the steering wheel up to the first gear to increase the cruise speed by 1 km/h.
- Push the lever up to the second gear to increase the cruise speed by the nearest multiple of 5 km/h. For example, if the current cruise speed is set at 57 km/h, pushing up to the second gear will display 60 km/h. When pushing and holding the second gear for a long time, the cruise speed will increase by multiples of 5 km/h.
- Push the lever down to the first gear to decrease the cruise speed by 1 km/h.
- Push the lever down to the second gear to decrease the cruise speed by the nearest multiple of 5 km/h. For example, if the current cruise speed is set at 57 km/h, pushing down to the second gear will display 55 km/h. When pushing and holding the second gear for a long time, the cruise speed will decrease by multiples of 5 km/h.

The maximum set speed for ACC is 130 km/h. The minimum set speed is 30 km/h.

 **Warning**

- When using ACC, please strictly adhere to road traffic safety regulations.

## VI. Adjust follow-up time headway

There are three gears for adjusting the follow-up time headway, which can be adjusted using the knob switch on the right side of the steering wheel:

- Rotate outward to reduce the time headway, with each click reducing one gear.
- Rotate inward to increase the time headway, with each click increasing one gear.

## VII. Function limitation

In the following scenarios, ACC function may have limited performance or may not be available:

- In a curve with a large curvature.
- On steep slopes, use ACC with caution, as there is a risk of the vehicle rolling back when following-up and starting.

Camera perception-restricted scenarios, including but not limited to:

- Dim lighting conditions causing a decrease in recognition capabilities, such as at night, in the shade, during twilight, in tunnels, or in areas where shadows are cast on the road.
- Obstructed or dirty cameras, or camera installation position changed or loose, resulting in angle deviation.

## 7. Driving

- Strong light, backlight, reflection and abrupt changes in brightness, such as direct sunlight during the day, especially in summer, flashlights in the surrounding environment, road surface water reflection, entering or exiting tunnels.
- Extreme weather conditions such as high temperature, severe cold, causing the camera's performance to decline.
- Dust, water vapor, water droplets, dirt, or ice on the windshield in front of the camera, obstructing the camera's field of view.
- Severe weather conditions, such as rain, snow, fog, smog, sandstorms, etc.

Millimeter-wave radar perception-restricted scenarios, including but not limited to the following situations:

- The millimeter-wave radar position changed or loose, resulting in angle deviation.
- The radar being obstructed by mud, ice, metal objects, etc.
- Extreme weather conditions such as high temperature, severe cold, causing the radar's perception capabilities to decline.
- Vehicle collisions causing the radar's installation position area to be hit or the vehicle surface to be deformed.
- Electromagnetic field interference in the surrounding environment, such as heavy fog, rain, snow, or sandstorms.
- Due to the limitation of the characteristics of radar electromagnetic waves, there may be misidentification in some special scenarios, such as metal guardrail, green belt, cement wall, construction area, etc.

LIDAR perception-restricted scenarios, including but not limited to the following situations:

- The LIDAR's installation position being changed or loose, resulting in angle deviation.
- Severe weather conditions, such as rain, snow, fog, smog, sandstorms, etc.
- High temperature or severe cold causing the LIDAR's perception capabilities to decline.
- LIDAR's installation surface being obstructed by water, mud, car cover, car film, metal, ice and snow, frost, etc.
- Vehicle collisions causing the LIDAR's installation position area to be hit or scratched, or the vehicle surface to have scratches or deformations.
- The exhaust, water splashes, snowflakes, or dust formed by the vehicle in front.
- Direct strong light, backlight, water reflection, or flash interference, etc.

Only standard vehicle targets will be recognized and responded to. The following target scenarios cannot be recognized, including but not limited to:

- Horizontal vehicle target.
- Pedestrians or two-wheeled, three-wheeled, and other motorized vehicles.
- Road obstacles, such as water horses, crash cushions, cones, posts, triangular warning signs, etc.
- Vehicles driving across or in the opposite direction.

- Non-vehicle targets such as fences, traffic lights, road signs, barrier poles, walls, animals, etc.
- Special vehicle targets such as construction vehicles, engineering vehicles, heterogeneous vehicles, etc.

In the following scenarios, if the relative speed to the vehicle in front is too high, the ACC may not brake and decelerate in time:

- The vehicle ahead is stationary or moving slowly, especially at night or during uphill or downhill driving, where recognition may be delayed.
- The vehicle ahead suddenly brakes.
- A vehicle in an adjacent lane cuts into the path ahead of your vehicle.
- Your vehicle suddenly cuts into the path behind the vehicle in front.

### Warning

- The ACC is a longitudinal comfort driving assist function. In any situation, you need to continuously monitor the road conditions and maintain active control of the vehicle.
- The ACC cannot detect all obstacles. If the vehicle or an obstacle in front is only partially in the lane, or if your vehicle is partially in the lane, the ACC may not apply the brakes or decelerate. Please remain vigilant and be prepared to take over the vehicle at any time.
- It is not recommended to use ACC function in adverse weather conditions such as rain, snow, fog, smog, sandstorms, road puddles, icy roads, etc.
- The ACC is suitable for use on highways, national roads, main roads and other straight roads. It is not recommended to use ACC on muddy, narrow, non-standardized roads, uphill and downhill roads, sharp turns, crowded and crossroads with complex traffic conditions.
- It is not recommended to use ACC in complex traffic scenarios such as busy city areas, pedestrian or bicycle-heavy roads, intersections and congested sections.
- The above warnings and limitations do not cover all possible situations that may affect ACC. During use, various factors may interfere with the operation of the ACC system. To avoid safety incidents, please stay focused and always pay attention to the traffic environment, road conditions and vehicle status.
- The ACC may unexpectedly exit due to unforeseen circumstances. Please always pay attention to the traffic conditions and road environment, and be ready to take over the vehicle at any time.

### 7.6.3 Lane change assist

Lane change assist (LCA). When the vehicle speed is between 15 km/h and 130 km/h, the LCA can be activated. When the driver turns on the turn signal light or performs a lane change action, the system will judge whether the environment of the adjacent lane on the corresponding side meets the lane change requirements. If the requirements are not met, the system will send a warning message through the central control screen.

#### I. Setting

## 7. Driving

You can enable or disable the LCA by clicking “Vehicle Settings → Intelligent Driving → Active Safety → Door Open Warning” .

Level 1 alarm

Level 2 alarm

II. Function limitation

The camera’s imaging capabilities may be affected, including but not limited to the following:

- Poor visibility due to nighttime.
- Poor visibility due to severe weather conditions (e.g., heavy rain, heavy snow, dense fog, sandstorms, etc.).
- Strong light, backlight, water reflection and extreme light contrast.
- The camera is obstructed by mud, ice, snow, etc.
- Extreme weather conditions such as high temperature, severe cold, causing the camera’s performance to decline.

The detection capability of the LIDAR may be affected, including but not limited to:

- Severe weather conditions, such as rain, snow, smog, sandstorms, etc.
- Direct strong light, backlight of water reflection.
- The exhaust, water splashes, snowflakes, or dust formed by the vehicle in front.
- Extreme weather conditions such as high temperature, severe cold, etc.
- The LIDAR’s transceiver window is obstructed by rain, mud, ice, frost, snow, or car film.
- The LIDAR transceiver window is damaged by external force, resulting in scratches or breaks.

### Warning

- The LCA is a driving assist function. This function cannot replace the driver's observation and judgment of traffic conditions, as well as the driver's responsibility for driving the vehicle safely.

### 7.6.4 Rear collision Warning

Rear collision warning (RCW). When the vehicle speed is between 0~130 km/h, if your vehicle judges that there is a collision risk between your vehicle and the vehicle behind, the rear collision warning function will send visual, auditory and tactile alarm information to remind the driver. The alarm will automatically cancel when the collision risk disappears.

I. Setting

Turn on the early warning + braking function by clicking “Vehicle Settings → Intelligent Driving → Active Safety → Rear Collision Warning” through the central control screen.

- Select “Not enable” to turn off the forward-facing collision warning function.
- Select “Warning” or “Warning + Braking” to enable the rear collision warning function.

### Caution

- The rear collision warning function is set to be enabled by default each time the vehicle is powered

on.

- When selecting the warning function, the system will only send warning prompts in a dangerous situation and will not take braking measures.

### Tip

- When the rear collision warning function is triggered, a text pop-up + strong sound alarm prompt will appear on the instrument panel. When the situation is more dangerous, there will also be accompanied by tactile alarms such as steering wheel vibration and light braking.

## II. Function limitation

The rear collision warning function may have limited performance or may not work in the following scenarios:

- In a curve with a large curvature.
- Outside the speed range for which the forward-facing collision warning function is designed to operate.
- Uphill or downhill roads or bumpy roads.

Camera perception-restricted scenarios, including but not limited to:

- Dim lighting conditions causing a decrease in recognition capabilities, such as at night, in the shade, during twilight, in tunnels, or in areas where shadows are cast on the road.
- The camera being obstructed or dirty.
- The camera's installation position being changed or loose, resulting in angle deviation.
- Strong light, backlight, reflection and abrupt changes in brightness, such as direct sunlight during the day, especially in summer, flashlights in the surrounding environment, road surface water reflection, entering or exiting tunnels.
- Extreme weather conditions such as high temperature, severe cold, causing the camera's performance to decline.
- Dust, water vapor, water droplets, dirt, or ice on the windshield in front of the camera, obstructing the camera's field of view.
- Severe weather conditions, such as rain, snow, fog, smog, sandstorms, etc.

Millimeter-wave radar perception-restricted scenarios, including but not limited to the following situations:

- The radar's installation position being changed or loose, resulting in angle deviation.
- The radar being obstructed by mud, ice, metal objects, etc.
- Extreme weather conditions such as high temperature, severe cold, causing the radar's perception capabilities to decline.
- Vehicle collisions causing the radar's installation position area to be hit or the vehicle surface to be deformed.
- Electromagnetic field interference in the surrounding environment, such as heavy fog, rain, snow, or sandstorms.

## 7. Driving

- Due to the limitation of the characteristics of radar electromagnetic waves, there may be misidentification in some special scenarios, such as metal guardrail, green belt, cement wall, construction area, etc.

LIDAR perception-restricted scenarios, including but not limited to the following situations:

- The LIDAR's installation position being changed or loose, resulting in angle deviation.
- Severe weather conditions, such as rain, snow, fog, smog, sandstorms, etc.
- High temperature or severe cold causing the LIDAR's perception capabilities to decline.
- LIDAR's installation surface being obstructed by water, mud, car cover, car film, metal, ice and snow, frost, etc.
- Vehicle collisions causing the LIDAR's installation position area to be hit or scratched, or the vehicle surface to have scratches or deformations.
- The exhaust, water splashes, snowflakes, or dust formed by the vehicle in front.
- Direct strong light, backlight, water reflection, or flash interference, etc.

Only standard vehicle targets will be recognized and responded to. The following target scenarios cannot be recognized, including but not limited to:

- Horizontal vehicle target.
- Pedestrians or two-wheeled, three-wheeled, and other motorized vehicles.
- Road obstacles, such as water horses, stone pillars, crash cushions, cones, posts, triangular warning signs, etc.
- Vehicles driving across or in the opposite direction.
- Non-vehicle targets such as fences, traffic lights, road signs, barrier poles, walls, animals, etc.
- Special vehicle targets such as construction vehicles, engineering vehicles, heterogeneous vehicles, etc.

### Warning

- The rear collision warning function is a driving assist alarm function. This function cannot replace the driver's monitoring of dangerous targets on the road. Please do not rely too much on this function.
- The above warnings and limitations do not cover all possible situations that may affect the normal operation of the rear collision warning function. During use, various factors may interfere with the function's operation. To avoid safety incidents, please stay focused and always pay attention to the traffic environment, road conditions and vehicle status.
- The driver has the highest control over the vehicle. When the driver performs the following operations, it may result in the rear collision warning function not sending an alarm or the alarm being interrupted, including but not limited to:
  - The driver presses the brake pedal.
  - The driver heavily or suddenly presses the accelerator pedal.

- The driver sharply turns the steering wheel.
- The driver unbuckles the safety belt.
- The driver shifts to a non-D gear.

### 7.6.5 Blind spot detection assist

Blind spot detection (BSD) assist. When your vehicle speed is between 12 km/h and 150 km/h, if there is a vehicle moving or rapidly approaching from behind or diagonally behind your vehicle, the vehicle will alert the driver through steering wheel vibration and external mirror indicators.

#### I. Setting

To enable or disable BSD warning, click “Vehicle Settings → Intelligent Driving → Active Safety → BSD Warning” through the central control screen.

- Select “Not enable” to turn off the BSD warning.
- Select “Lights” to enable BSD warning with only external mirror indicators alerting the driver.
- Select “Vibration + Lights” to enable BSD warning, alerting the driver through steering wheel vibration and external mirror indicators.

#### II. Prompt information

When the BSD assist is in the alarm state, the indicator on the corresponding side exterior mirror illuminates, and the steering wheel vibrates to alert the driver, with a yellow sector symbol on the corresponding side displayed in the instrument screen.

If the turn signal light on this side is activated at this time, the exterior mirror indicator on the corresponding side will flash, and the steering wheel will vibrate to alert the driver, with the sector area on the instrument panel turning red. The driver should avoid changing lanes at this time.

#### III. Function limitation

In the following situations, the BSD warning function may be limited or unable to operate normally, including but not limited to:

- The function’s activation may be delayed in response to vehicles rapidly approaching from adjacent lanes.
- The function’s activation may be delayed or may not trigger at all for smaller targets such as bicycles and motorcycles.
- Drivers should fully utilize the interior and exterior mirrors to observe the vehicle’s surroundings, as the BSD warning function cannot replace the function of rearview mirrors.
- The BSD warning function is primarily intended for urban and highway conditions under normal weather conditions. Its alarm accuracy cannot be guaranteed in special conditions (e.g., heavy rain, snow, standing water, fog, nighttime, tunnels, sandy, dusty or grassy road surfaces, etc.).

The camera’s imaging capabilities may be affected, including but not limited to the following:

- Poor visibility due to nighttime.



## 7. Driving

- Strong light, backlight, water reflection, extreme light contrast, or rapid changes in brightness (e.g., entering or exiting tunnels).
- Extreme weather conditions such as high temperature, severe cold, causing the camera's performance to decline.
- The camera may be obstructed by mud, ice, snow, or other objects, affecting its detection range.
- Poor visibility due to severe weather conditions (e.g., heavy rain, heavy snow, dense fog, sandstorms, etc.).

### Warning

- The BSD function is a driving assist function. This function cannot replace the driver's observation and judgment of traffic conditions, as well as the driver's responsibility for driving the vehicle safely.
- Drivers should not overly rely on the BSD warning function, avoid deliberately testing the function's triggering, or deliberately waiting for the function to trigger. Due to inherent limitations in system performance, false triggers and missed triggers cannot be completely avoided.

### 7.6.6 Lane centering control

Lane centering control (LCC) is based on ACC and adds a lateral control function for the vehicle. The LCC collects lane line information through the front view camera and, under certain conditions, applies steering torque in real-time to assist the driver in correcting the driving trajectory, keeping the vehicle centered in the current lane.

### Tip

- The LCC can only be activated when there are clear lane lines on both sides. During the activation process, if the lane line disappears, the LCC will temporarily be downgraded to the ACC state. If the lane line reappears, the function will be restored to the LCC.

#### I. Enabling/disabling LCC

Set the activation and deactivation of the LCC by clicking “Vehicle Settings → Intelligent Driving → Driving Assist→ LCC” through the central control screen.

#### II. Activating LCC

When LCC meets the following working conditions, a gray icon indicating that LCC can be activated appears on the instrument panel. By inwardly pulling the right side lever on the steering wheel twice, you can activate the LCC function:

- The driver's seat belt is fastened.
- The driver needs to hold the steering wheel.
- All doors are closed.
- The vehicle is in D gear.
- The driver does not depress the brake pedal.

- The speed does not exceed 130 km/h.

After activating LCC, when there is no preceding vehicle, the LCC applicable speed range is 30~130 km/h. When there is a preceding vehicle, the LCC applicable speed range is 0~130 km/h. When the vehicle speed is below 30 km/h and the function is activated, set 30 km/h as the cruise speed. When the vehicle speed is above 30 km/h and the function is activated, set the current speed as the cruise speed.

### Tip

- When applying the LCC, you can briefly depress the accelerator pedal to operate the vehicle in a short time. At this point, LCC will no longer respond to the target preceding vehicle. When you release the accelerator pedal, the system will control the vehicle to return to the cruise speed.

### III. Operation of LCC

The activation, exit, and setting operations of the LCC function can be achieved by pulling the right side lever on the steering wheel:

- Pull inward twice to activate the LCC function.
- Pull up twice to increase cruising speed or restore cruising speed.
- Pull down to reduce the cruising speed.
- Turn outward to reduce the follow-up time headway.
- Turn inward to increase the follow-up time headway.
- Pull outward once to exit the LCC function.

### Warning

- The LCC may unexpectedly exit due to unforeseen circumstances. Please always pay attention to the traffic conditions and road environment, and be ready to take over the vehicle at any time.

### IV. Exit LCC

Pull the gear lever on the right side of the steering wheel outward once, depress the brake pedal, or the driver takes hand-off (not holding the steering wheel).

### Tip

- If the vehicle follows for more than 5 min, the LCC function will exit.
- During the activation of LCC, if the driver's hands are off the steering wheel, a hand-off alarm prompt will be sent. Please ensure that you hold the steering wheel. The alarm has three levels, and after the third level, regardless of whether you take over control, the function will exit, and the activation will be suppressed for a period of time after exiting.

### V. LCC speed adjustment

When the LCC is in an activated mode:

## 7. Driving

- Push the lever on the right side of the steering wheel up to the first gear to increase the cruise speed by 1 km/h.
- Push the lever up to the second gear to increase the cruise speed by the nearest multiple of 5 km/h. For example, if the current cruise speed is set at 57 km/h, pushing up to the second gear will display 60 km/h. When pushing and holding the second gear for a long time, the cruise speed will increase by multiples of 5 km/h.
- Push the lever down to the first gear to decrease the cruise speed by 1 km/h.
- Push the lever down to the second gear to decrease the cruise speed by the nearest multiple of 5 km/h. For example, if the current cruise speed is set at 57 km/h, pushing down to the second gear will display 55 km/h. When pushing and holding the second gear for a long time, the cruise speed will decrease by multiples of 5 km/h.

The maximum set speed for LCC is 130 km/h, and the minimum set speed is 30 km/h, but it can follow to 0 km/h.

### Warning

- When using LCC, please strictly adhere to road traffic safety regulations.

### VI. Follow-up time headway adjustment

There are two gears for adjusting the follow-up time headway, which can be adjusted using the knob switch on the right side of the steering wheel:

- Rotate outward to reduce the time headway, with each click reducing one gear.
- Rotate inward to increase the time headway, with each click increasing one gear.

### VII. Follow-up start-stop function

Following: In the following cruise state, the vehicle automatically adjusts its speed and distance based on the speed of the vehicle in front. If the vehicle in front slows down and stops, the vehicle will also brake automatically until it stops.

Starting: If the following vehicle in front starts within 1 min, it will automatically follow up. If the following vehicle in front starts between 1 and 5 min, it will prompt the user to lightly depress the accelerator pedal to confirm following up. If following the vehicle in front for more than 5 min, the vehicle will engage the electronic parking brake (EPB) and exit the LCC function.

### Warning

- In some cases, the LCC may not detect traffic participants around the vehicle, or the perception is ineffective or untimely due to interference factors. Therefore, when the vehicle follows and starts, you need to always pay attention to the traffic conditions and the surrounding road environment to avoid collisions.

### VIII. Degradation of LCC function

The following situations may cause the lateral control of LCC to exit, and the function will temporarily downgrade to ACC state. It will resume to LCC when all the following suppressions do not exist: Including but not limited to:

- Disappear of lane lines, water accumulation, obstruction, lack of clarity, severe wear, crossing, shadowed by vehicles or buildings.
- Camera field of view is limited, such as rain, snow, fog, smog, sandstorms, obstruction, direct sunlight, nighttime, etc.
- Passing a curve with a large curvature.
- Passing a section without lane lines, such as non-standardized roads, intersections, construction areas, etc.
- Too narrow or wide lane line spacing on both sides of the road.
- Road bumps or steep slopes resulting in inaccurate recognition of lane lines.
- The driver actively exerts excessive steering torque.
- The steering wheel rotation speed is too fast or the steering angle is too large.

### IX. Evading large vehicle

During the activation of LCC, if a large vehicle (wagon, truck, etc.) from the adjacent lane approaches your line, the vehicle will automatically steer to the other side to maintain a safe distance.

Activate or deactivate the large vehicle evading function by clicking “Vehicle Settings → Intelligent Driving → Driving Assist→ LCC” through the central control screen.

#### Caution

- Large vehicle evading is suitable for situations where the large vehicle in the adjacent lane has not invaded your lane and there is a safe space on the other side, and your vehicle steers to the other side to evade a certain distance (still within the your lane). Because the road scene is relatively complex and large vehicles are dangerous, in the case of encountering large vehicles, you need to continue to pay attention to the road and be ready to take over the vehicle at any time.

### X. CLC

Commanded lane change (CLC) is based on the activation of LCC or NOC functions. If the vehicle has enabled the CLC function and meets the activation conditions, the left/right steering wheel lever can be used to control the vehicle to complete the lane change. CLC is mainly suitable for dry, smooth and clearly marked standardized long straight roads, such as highways, urban expressways, highways, long straight trunk roads, etc.

## 7. Driving

Activate or deactivate the CLC function by clicking “Vehicle Settings → Intelligent Driving → Driving Assist → LCC” through the central control screen. When using the CLC function, the following requirements must be met:

- The LCC function is activated.
- The driver holds the steering wheel.
- The current speed is greater than 40 km/h.
- The vehicle is driving on a straight road.

The current lane and the target lane meet the safe lane change conditions, including but not limited to:

- The lane line on the change side is a dashed line or a dashed solid line.
- There is a safe lane change space on the target lane (with open space at the front and rear).
- Your vehicle maintains a sufficient safe distance with the vehicle in front in the current lane.
- There are no blind spot monitoring or lane change assist alarms in the target lane
- The curvature of both the current lane and the target lane is relatively small.
- The lane lines of the current lane and the target lane are clear.

### Warning

- When using CLC, please strictly adhere to road traffic safety regulations. The CLC may unexpectedly exit due to unforeseen circumstances. Please always pay attention to the traffic conditions and road environment, and be ready to take over the vehicle at any time.
- The CLC is merely a lane change assist system. Before and during lane changes, you must remain focused at all times, confirming that the lane change process and vehicle movement are safe. Please note that the CLC cannot respond to pedestrians, two-wheelers, non-vehicular obstacles, oncoming vehicles, etc. Do not rely solely on the driving path judged by the CLC. You always bear the ultimate responsibility for safe lane changes.

### Caution

- The LCL can only be performed once each time.

### Tip

- You should judge whether the conditions for changing lanes are met. Before changing lanes, please visually check again and confirm that the environment for changing lanes is safe, and then pull the corresponding side turn signal light lever.
- After the turn signal light is turned on, if the system detects that the lane change conditions are met, it will execute the lane change. If the system judges that the current lane change conditions are not

met, it will directly terminate the lane change. Or if the waiting conditions are met, it will continue to wait for a period of time to seek a lane change opportunity. If there is still no lane change opportunity after 30 s, the lane change will be terminated.

- During the lane change process, you can cancel the current lane change by pulling back the turn signal light lever or reversing the turn signal light lever. If the vehicle center has already crossed the lane line during cancellation, the lane change will continue to be completed. If the vehicle center has not crossed the lane line, it will be pulled back to the original lane.
- If the blind spot detection or LCC alarm activates on the side of the lane change, or there is no lane change space in front of the target lane due to a vehicle in front, CLC will pause the lane change and continue to wait for an opportunity.
- During the CLC lane change process of CLC, if there is a vehicle in the adjacent lane simultaneously changing lanes to the target lane, due to distance and angle, the CLC may not be able to recognize it. Please be aware to take over the vehicle for avoidance.
- The CLC may miss detecting stationary or slowly moving vehicles, especially at night, so please be particularly careful.

### XI. Function limitation

In the following scenarios, CLC function may have limited performance or may not be available:

- In a curve with a large curvature.
- Lane lines are unclear, damaged, obstructed, crossed, disconnected, flooded, or covered by shadows.
- Too narrow or wide lane line spacing on both sides of the road.
- On steep slopes, use ACC with caution on steep roads, as there is a risk of the vehicle rolling back when following-up and starting.

Camera perception-restricted scenarios, including but not limited to:

- Dim lighting conditions causing a decrease in recognition capabilities, such as at night, in the shade, during twilight, in tunnels, or in areas where shadows are cast on the road.
- The camera being obstructed or dirty.
- The camera's installation position being changed or loose, resulting in angle deviation.
- Strong light, backlight, reflection and abrupt changes in brightness, such as direct sunlight during the day, especially in summer, flashlights in the surrounding environment, road surface water reflection, entering or exiting tunnels.
- Extreme weather conditions such as high temperature, severe cold, causing the camera's performance to decline.
- Dust, water vapor, water droplets, dirt, or ice on the windshield in front of the camera, obstructing the camera's field of view.

## 7. Driving

- Severe weather conditions, such as rain, snow, fog, smog, sandstorms, etc.

Millimeter-wave radar perception-restricted scenarios, including but not limited to the following situations:

- The radar's installation position being changed or loose, resulting in angle deviation.
- The radar being obstructed by mud, ice, metal objects, etc.
- Extreme weather conditions such as high temperature, severe cold, causing the radar's perception capabilities to decline.
- Vehicle collisions causing the radar's installation position area to be hit or the vehicle surface to be deformed.
- Electromagnetic field interference in the surrounding environment, such as heavy fog, rain, snow, or sandstorms.
- Due to the limitation of the characteristics of radar electromagnetic waves, there may be misidentification in some special scenarios, such as metal guardrail, green belt, cement wall, construction area, etc.

LIDAR perception-restricted scenarios, including but not limited to the following situations:

- The LIDAR's installation position being changed or loose, resulting in angle deviation.
- Severe weather conditions, such as rain, snow, fog, smog, sandstorms, etc.
- High temperature or severe cold causing the LIDAR's perception capabilities to decline.
- LIDAR's installation surface being obstructed by water, mud, car cover, car film, metal, ice and snow, frost, etc.
- Vehicle collisions causing the LIDAR's installation position area to be hit or scratched, or the vehicle surface to have scratches or deformations.
- The exhaust, water splashes, snowflakes, or dust formed by the vehicle in front.
- Direct strong light, backlight, water reflection, or flash interference, etc.

Only standard vehicle targets will be recognized and responded to. The following target scenarios cannot be recognized, including but not limited to:

- Horizontal vehicle target.
- Pedestrians or two-wheeled, three-wheeled, and other motorized vehicles.
- Road obstacles, such as water horses, crash cushions, cones, posts, triangular warning signs, etc.
- Vehicles driving across or in the opposite direction.
- Non-vehicle targets such as fences, traffic lights, road signs, barrier poles, walls, animals, etc.
- Special vehicle targets such as construction vehicles, engineering vehicles, heterogeneous vehicles, etc.

In the following scenarios, if the relative speed to the vehicle in front is too high, the LCC may not brake and decelerate in time:

- The vehicle ahead is stationary or moving slowly, especially at night or during uphill or downhill driving, where recognition may be delayed.

- The vehicle ahead suddenly brakes.
- A vehicle in an adjacent lane cuts into the path ahead of your vehicle.
- Your vehicle suddenly cuts into the path behind the vehicle in front.

### Warning

- The LCC is a comfort driving assist function. In any situation, you need to continuously monitor the road conditions and maintain active control of the vehicle.
- The LCC cannot detect all obstacles. If the vehicle or an obstacle in front is only partially in the lane, or if your vehicle is partially in the lane, the LCC may not apply the brakes or decelerate. Please remain vigilant and be prepared to take over the vehicle at any time.
- It is not recommended to use LCC function in adverse weather conditions such as rain, snow, fog, smog, sandstorms, road puddles, icy roads, etc.
- The LCC is suitable for use on highways, national roads, main roads and other straight roads. It is not recommended to use LCC on muddy, narrow, non-standardized roads, uphill and downhill roads, sharp turns, crowded and crossroads with complex traffic conditions.
- It is not recommended to use LCC in complex traffic scenarios such as busy city areas, pedestrian or bicycle-heavy roads, intersections and congested sections.
- The above warnings and limitations do not cover all possible situations that may affect the normal operation of the LCC function. During use, various factors may interfere with the LCC operation. To avoid safety incidents, please stay focused and always pay attention to the traffic environment, road conditions and vehicle status.

### 7.6.7 Front crossing traffic alert

Front crossing traffic alert (FCTA). When your vehicle speed is less than 15 km/h, and a vehicle is detected crossing through the left and right blind spots in front of the vehicle, the vehicle will send a prompt message on the instrument panel.

#### I. Setting

You can enable or disable the FCTA function by clicking “Vehicle Settings → Intelligent Driving → Active Safety → FCTA” through the central control screen.

#### II. Function limitation

The camera’s imaging capabilities may be affected, including but not limited to the following:

- Poor visibility due to nighttime.
- Poor visibility due to severe weather conditions (e.g., heavy rain, heavy snow, dense fog, sandstorms, etc.).
- Strong light, backlight, water reflection and extreme light contrast.



## 7. Driving

- The camera is obstructed by mud, ice, snow, etc.
- Extreme weather conditions such as high temperature, severe cold, causing the camera's performance to decline.

The detection capability of the millimeter wave radar may be affected, including but not limited to:

- The radar is affected by the surrounding environment (e.g., electromagnetic field interference, underground parking lots, tunnels, railways, construction areas, width and height restrictions).
- The radar is obstructed by mud, ice, snow, etc.
- Extreme weather conditions such as high temperature, severe cold, causing the radar's performance to decline.

The detection capability of the LIDAR may be affected, including but not limited to:

- Severe weather conditions, such as rain, snow, smog, sandstorms, etc.
- Direct strong light, backlight of water reflection.
- The exhaust, water splashes, snowflakes, or dust formed by the vehicle in front.
- The LIDAR's transceiver window is obstructed by rain, mud, ice, frost, snow, or car film.
- Extreme weather conditions such as high temperature, severe cold, etc.
- The LIDAR transceiver window is damaged by external force, resulting in scratches or breaks.



### Warning

- The FCTA function is a driving assist alarm function. This function cannot replace the driver's monitoring of dangerous targets on the road. Please do not rely too much on this function.

### 7.6.8 Rear crossing traffic alert

Rear crossing traffic alert (RCTA). When the vehicle speed is less than 15 km/h, the RCTA function can monitor other vehicles, pedestrians, and non-motorized vehicles approaching from the side and rear while reversing, and send warning messages when a collision risk is detected. Thereby enhancing driving safety.

#### I. Setting

You can enable or disable the FCTA function by clicking "Vehicle Settings → Intelligent Driving → Active Safety → FCTA" through the central control screen.

#### II. Function limitation

The camera's imaging capabilities may be affected, including but not limited to the following:

- Poor visibility due to nighttime.
- Poor visibility due to severe weather conditions (e.g., heavy rain, heavy snow, dense fog, sandstorms, etc.).
- Strong light, backlight, water reflection and extreme light contrast.
- The camera is obstructed by mud, ice, snow, etc.
- Extreme weather conditions such as high temperature, severe cold, causing the camera's performance to decline.

The detection capability of the millimeter wave radar may be affected, including but not limited to:

- The radar is affected by the surrounding environment (e.g., electromagnetic field interference, underground parking lots, tunnels, railways, construction areas, width and height restrictions).
- The radar is obstructed by mud, ice, snow, etc.
- Extreme weather conditions such as high temperature, severe cold, causing the radar's performance to decline.

The detection capability of the LIDAR may be affected, including but not limited to:

- Severe weather conditions, such as rain, snow, smog, sandstorms, etc.
- Direct strong light, backlight of water reflection.
- The exhaust, water splashes, snowflakes, or dust formed by the vehicle in front.
- The LIDAR's transceiver window is obstructed by rain, mud, ice, frost, snow, or car film.
- Extreme weather conditions such as high temperature, severe cold, etc.
- The LIDAR transceiver window is damaged by external force, resulting in scratches or breaks.

### Warning

- The RCTA function is a driving assist alarm function. This function cannot replace the driver's monitoring of dangerous targets on the road. Please do not rely too much on this function.

### 7.6.9 Door open Warning

Door open warning (DOW). When the vehicle is stationary or the speed is less than 5 km/h, and passengers are opening the door to exit, the system will send an alarm prompt through the instrument panel and exterior mirrors when detecting approaching vehicles from the side and rear. Thereby reducing the risk of collision with other vehicles when exiting.

#### I. Setting

You can enable or disable the RCTA function by clicking "Vehicle Settings → Intelligent Driving → Active Safety → RCTA" .

#### II. Prompt information

When the vehicle is stationary and detects an approaching vehicle from the side and rear, the indicator on the corresponding side exterior mirror remains on, and the corresponding side of the instrument panel displays a yellow sector symbol.

When it is detected that there is an approaching vehicle on the side and rear and the corresponding side door is opening, the indicator on the exterior mirror flashes quickly, and the yellow sector inside the instrument panel turns red.

#### III. Function limitation

In the following situations, the DOW function may be limited or unable to operate normally, including but not limited to:

- The DOW function will not send an alarm for oncoming vehicles.
- The function's activation may be delayed in response to rapidly approaching target vehicles.

## 7. Driving

- The function's activation may be delayed or may not trigger at all for smaller targets such as pedestrians, bicycles and motorcycles.

The camera's imaging capabilities may be affected, including but not limited to the following:

- Poor visibility due to nighttime.
- Poor visibility due to severe weather conditions (e.g., heavy rain, heavy snow, dense fog, sandstorms, etc.).
- Strong light, backlight, water reflection, extreme light contrast, or rapid changes in brightness (e.g., entering or exiting tunnels).
- The camera may be obstructed by mud, ice, snow, or other objects, affecting its detection range.
- Extreme weather conditions such as high temperature, severe cold, causing the camera's performance to decline.



### Warning

- The DOW function may not work in all cases and cannot replace the driver's and occupants' visual observation. Actively observing the environment before opening the door is the most effective measure and responsibility for the driver and occupants to ensure personal safety.

### 7.6.10 Around view monitoring

Around view monitoring (AVM) provides a panoramic view of the vehicle's surroundings, including forward, rear and side views. This allows the driver to clearly understand the surrounding environment, including obstacles, pedestrians, other vehicles, parking lots, etc. The AVM helps the driver better assess the vehicle's position and distance for safe driving and parking.

The AVM provides: regular viewing angle and wheel hub viewing angle. You can switch view angle to any position as needed to observe the vehicle's surroundings.

#### I. Entering AVM

##### 1. Manual entry

To manually enter the AVM interface, you can:

- Wake up the voice system and say wake words such as " Turn on AVM" .
- Click the "AVM" icon at the bottom of the central control screen's function bar.

##### 2. Automatic entry

Automatically enter the AVM interface in the following ways:

- The vehicle's power is not in the "OFF" mode, and the gear is shifted to R.
- When the vehicle is in R gear, the speed decreases from above 20 km/h to less than 10 km/h.
- When the vehicle is in D gear, an obstacle is detected in front of the vehicle.
- When the vehicle is in N gear, the vehicle slides and an obstacle is detected behind the vehicle.
- When the vehicle is in D gear, obstacles are detected on both sides of the vehicle.
- Turn on the turn signal light.

- Enter a narrow road.
- Automatically/remotely park.

### II. Exit AVM

#### 1. Manual exit

To manually exit the AVM interface, you can:

- Wake up the voice system and say wake words such as " Turn off AVM" .
- Click the "AVM" icon at the bottom of the central control screen's function bar.

#### 2. Automatic exit

Automatically exit the AVM interface in the following ways:

- The gear is shifted to P.
- The speed exceeds 20 km/h.
- Leave a narrow road.
- The obstacle disappears.
- In D/N gear, there is no radar trigger, no turn signal light trigger, and no user operation.

### III. View switching

The AVM has two view angles: Regular view and wheel hub view.

In the AVM interface, clicking "Regular View" will display a top-down view with front, left, right, and rear views.

Switching to the wheel hub view will display the front and rear wheel views of the vehicle.

#### Tip

- When there is no view switching for 3 s, the view switching button will automatically hide. You can manually select a view by clicking on the body of the vehicle.

### IV. Single side view switching

When the regular view is selected, clicking on the front, rear, left or right icon to switch to the corresponding side view.

- Front view

Manual switching: When the view is full-screen, click the front view icon to switch to the front view angle.

Automatic switching: When the AVM mode is enabled and the vehicle is in another view, switch to D gear to automatically switch to the front view or switch to the front view angle when an obstacle is detected ahead.

- Rear view

Manual switching: When the view is full-screen, click the rear view icon to switch to the rear view angle.

Automatic switching: When the vehicle switches to R gear or when an obstacle is detected behind the vehicle, it will automatically switch to the rear view angle.

#### Tip

## 7. Driving

- The left and right views can only be switched by manual clicking.
- Through the central control screen you can switch the AVM to full-screen display, floating window, or picture-in-picture display depending on different working conditions.

### V. Combined view

The combined view is composed of the front view, left view and right view. It is triggered by conditions such as turn signal lights and narrow roads.

### VI. Driving assist line

When the AVM function is activated, if the vehicle is not in P gear or the electronic handbrake is not activated, the AVM system will display the corresponding driving assist lines based on the gear position.

- Static driving assist line: It does not follow the steering wheel rotation, divided into three sections, with marking lines at 2.0 m/1.0 m/0.4 m respectively.
- Dynamic trajectory line: It changes in real-time according to the direction of the steering wheel rotation.

### VII. Tailgate opening reminder

During the process of reversing into a parking lot (including vertical and horizontal parking lots), to avoid the situation where the vehicle has been parked and the trunk cannot be opened, it needs to restart the vehicle and move forward before the tailgate can be opened normally. When the tailgate opening reminder function is turned on and the vehicle detects the real-time distance to the wall or other obstacles, if the distance exceeds the opening distance, the trunk door (including the spare tire) does not have enough space to open, the central control screen will prompt.

### VIII. Transparent chassis

The transparent chassis is an extended function of the AVM system. It uses four AVM cameras and vehicle speed, wheel speed and tire angle information to splice the image of the bottom of the vehicle.

- When the vehicle is in the "READY" mode but not moving, the AVM turns on the transparent body function, and the chassis and blind spot parts are gray.
- When the vehicle stops after driving less than one body length, the transparent chassis function is enabled, and the panoramic view displays the transparent area of the chassis based on the road surface information collected by the front camera.
- When the vehicle stops after driving more than one body length, the transparent body function is enabled, and the AVM immediately displays the transparent chassis.

### IX. One-click correction (subject to the real car)

After the vehicle has been used for some time, the camera position may have slight deviations. It is necessary to recalibrate the camera to maintain the best display state.

1. Click "Setting → One-click Correction" in the AVM interface.
2. Click "Start Correction."

3. During the correction process, the background correction is displayed. Keep the D gear state and drive forward in a straight line. The speed should be maintained at 5~7 km/h. Do not open the car door and tailgate during the correction process.

4. The correction process takes 2~3 minutes to complete. If the correction is terminated due to external conditions or exceeding 5 min, the correction interface will exit, and the correction needs to be restarted.

### X. Reverse radar

By clicking the sound icon in the AVM control interface, you can turn on or off the reverse radar sound prompt. It is turned on by default. It will be turned on by default the next time the vehicle is started.

#### Tip

- The vehicle will prompt different frequencies of alarm sounds according to different obstacle distances.

## 7.7 Brake system

### 7.7.1 Electronic handbrake (EPB)

#### I. Activating or deactivating the electronic handbrake

Activation: When the vehicle is stationary, activate the electronic handbrake by clicking “Vehicle Settings → Vehicle → Driving → Electronic Handbrake” through the central control screen or pressing the P gear button. At this time, the electronic handbrake brake indicator on the instrument panel illuminates.

Deactivation: When the vehicle is stationary, press the brake pedal, and deactivate the electronic handbrake by clicking “Vehicle Settings → Vehicle → Driving → Electronic Handbrake” through the central control screen or shifting the gear to D or R. At this time, the electronic handbrake brake indicator on the instrument panel turns off.

#### Tip

- It is normal that a certain amount of noise will be generated when the electronic handbrake is working.

#### II. Autohold activation

When the following conditions are met, press the brake pedal, and the vehicle decelerates to a stop. Deeply press the brake pedal to activate the Autohold function:

- The vehicle power supply is in “READY” mode.
- The driver’s side door is closed.
- The driver’s seatbelt is fastened.
- The gear is in D, N or R.

After Autohold is activated, the Autohold indicator on the instrument panel illuminates, indicating that the vehicle is parked. At this time, you can release the brake pedal.

#### III. Autohold deactivation

After Autohold is activated, press the accelerator pedal or brake pedal when starting to deactivate Autohold.

## 7. Driving

For safety reasons, Autohold will be forcibly deactivated and the electronic handbrake will be automatically activated in the following situations:

- The vehicle power is in “OFF” or “ON” mode.
- The gear is shifted to P.
- The driver’s side door is open.
- Autohold has been working for 6 min.
- After Autohold is deactivated, the Autohold indicator on the instrument panel turns off.

### Warning

- When the brake system or power supply is faulty, activating Autohold may cause the vehicle to slide. Please drive cautiously based on the road conditions.

#### IV. Wiping brake disc

Wiping brake disc can remove the water film adhering to the brake disc, ensure the cleanliness of the brake disc, effectively improve the braking effect during emergency braking, shorten the braking distance, and enhance driving safety.

During driving, when the vehicle sensor detects rain or the windshield wiper is activated, the brake disc wiping function is automatically activated. The brake disc wiping is turned off if the wiper is closed or the vehicle speed does not reach the threshold.

### 7.7.2 Electronic stability program (ESP)

The electronic stability program (ESP) recognizes the vehicle’s driving state through sensors installed on the vehicle. When the vehicle appears understeer, oversteer, or drive slip, ESP will actively adjust the driving torque or apply braking force to reduce the risk of skidding or spinning, thereby ensuring the vehicle’s driving safety.

#### I. Indicator

When ESP is working, the ESP indicator on the instrument panel flashes. When ESP fails, the ESP indicator on the instrument panel remains on. Please drive carefully and contact the ROX Service Center immediately to avoid vehicle damage or accidents.

### Warning

- Modifying the vehicle (including the braking system, suspension, steering system, tire structure, wheel and tire size) may change the vehicle’s handling characteristics. This may have a negative impact on the performance of ESP.
- ESP cannot exceed the physical limits of road adhesion and cannot prevent accidents caused by dangerous driving or high-speed emergency steering. Please drive cautiously according to road conditions.

### 7.7.3 Anti-lock brake system (ABS)

The main function of ABS is to adjust the braking pressure on the four wheels of the vehicle during emergency braking to prevent wheel lock-up, ensuring that the vehicle retains steering capability during emergency braking, reducing braking distance, and enhancing vehicle safety.

In normal braking, ABS will not be activated. In emergency braking, ABS is activated, and the driver can feel the brake pedal vibrate. At this time, drive according to the road conditions.

### Warning

- The driver must always maintain a safe distance from the vehicle ahead and be aware of potential hazards while driving. ABS can improve braking distance, but it cannot surpass the laws of physics. When there is a layer of water between the tires and the road surface, and the tires cannot directly contact the road, ABS cannot prevent the danger of wheel slip.

### Tip

- When ABS is activated, the ABS indicator on the instrument panel flashes, accompanied by ABS working noise, which is a normal phenomenon. If the ABS fault light remains on, please contact the ROX Service Center immediately.

### 7.7.4 Electronic brake-force distribution (EBD)

The main function of electronic brake-force distribution (EBD) is to automatically adjust the braking force between the front and rear axles of the vehicle when braking causes a shift in axle load, ensuring that the vehicle has the best braking performance.

### Tip

- When EBD is working, the EBD indicator flashes. If the EBD fault light remains on, please contact the ROX Service Center immediately.

### 7.7.5 Traction control system (TCS)

The main function of traction control system (TCS) is to prevent the driving wheels from slipping when the vehicle starts on ice, snow, or wet surfaces, or when the vehicle accelerates sharply. TCS adjusts the vehicle's output torque and controls braking pressure to minimize wheel spin as much as possible, thereby improving vehicle stability and comfort.

### Tip

- When TCS is activated, the indicator on the instrument panel flashes. If the vehicle is stuck in mud, deep snow, rocks, sand, or other surfaces and cannot be driven out, the escape function can be activated. TCS will control wheel slip while trying to maintain sufficient driving torque to help the vehicle get out of trouble.

### 7.7.6 Hydraulic brake assist (HBA)



## 7. Driving

When the driver rapidly presses the brake pedal, the hydraulic brake assist (HBA) can recognize that the vehicle is in an emergency state and quickly increase braking pressure to its maximum value, allowing the ABS to intervene more quickly and effectively shorten the braking distance.

### Warning

- HBA can enhance driving safety but cannot eliminate the risks caused by following too close, vehicle slip, speeding, or sharp turns. Please drive cautiously.

### 7.7.7 Roll motion intervention (RMI)

When the vehicle is turning, the roll motion intervention (RMI) detects the vehicle's motion state to judge if there is a risk of rollover. If there is a risk of rollover, RMI will apply braking and deceleration to one or more wheels to prevent the vehicle from rolling over.

### Warning

- RMI is an assist function and cannot completely eliminate the risk of rollover. The driver should drive safely to ensure driving safety.

### 7.7.8 Cornering stability control (CSC)

The cornering stability control (CSC ) system can control the braking pressure on the front wheels of the vehicle during cornering braking. This avoids the inner wheels from locking up prematurely, and improves the vehicle's driving stability.

### 7.7.9 Dynamic parking brake (CDP)

During driving, if an emergency situation such as brake failure occurs, you can press and hold the P gear button to activate the CDP function, and the vehicle will decelerate within a certain range of deceleration values. Release the P gear button, and CDP will immediately exit.

### Warning

- Do not use this function under non-emergency conditions to avoid safety accidents during driving.

### Tip

- Short pressing the P gear button during driving will not activate the CDP function. During the activation of the CDP function, the electronic handbrake indicator on the instrument panel flashes.

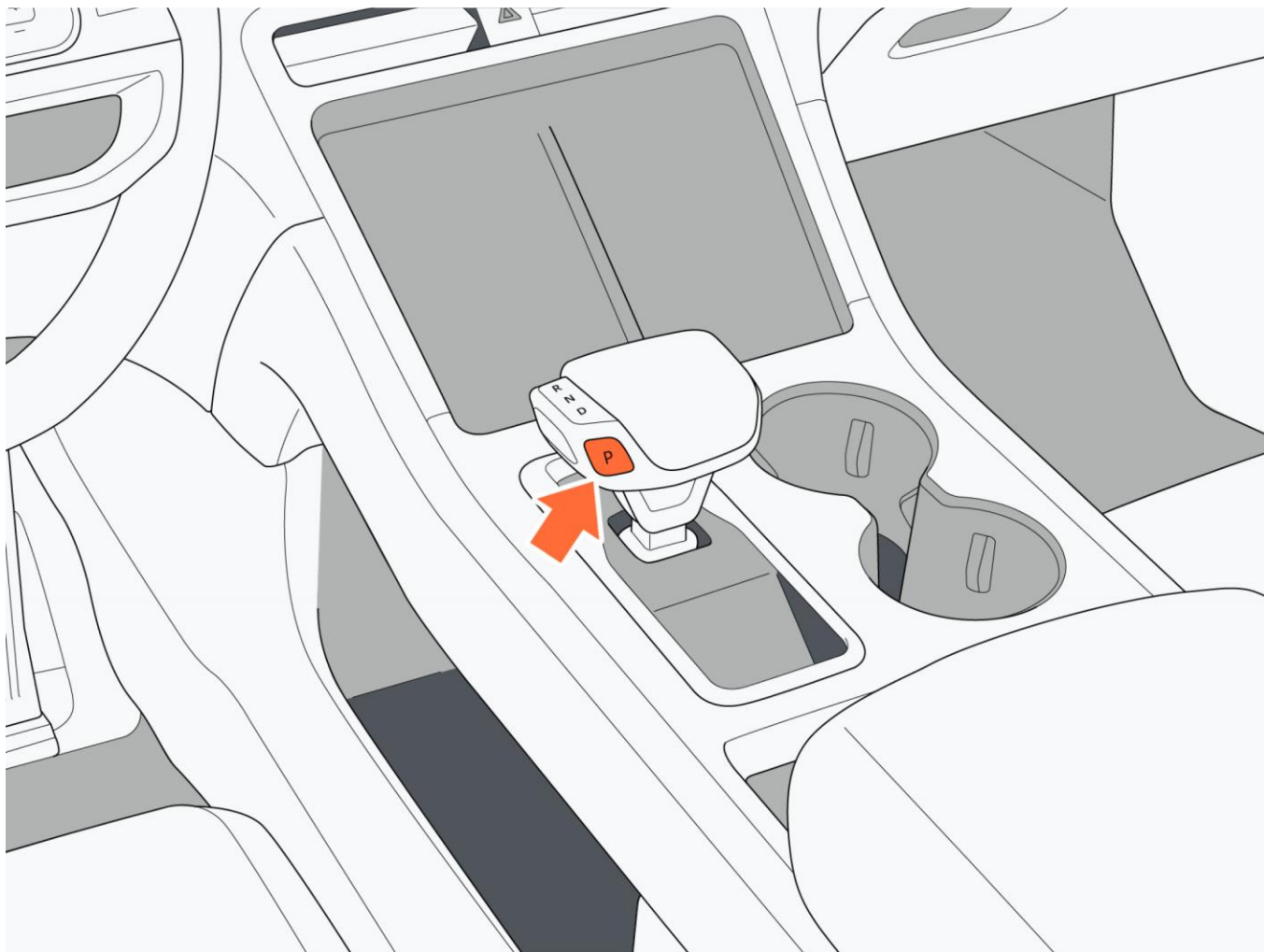

### 7.7.10 Hill descent control (HDC)

#### I. Activation/deactivation of HDC

You can activate and deactivate the hill descent control by clicking “ROX Mode → HDC” through the central control screen.

When the vehicle is descending a slope, and the conditions for activating the HDC are met, the system will automatically adjust the vehicle’s output torque or apply a certain braking force to the wheels to ensure a smooth descent.

After HDC is activated, the HDC indicator on the instrument panel illuminates. When HDC is activated during the descent, the HDC indicator on the instrument panel flashes.

#### **i** Tip

- When the vehicle speed is below 30 km/h, HDC can be enabled. When HDC is enabled. When the vehicle speed is in the range of 5 km/h to 30 km/h, and the vehicle is on a steep slope, HDC is activated. When the vehicle speed is in the range of 30 km/h to 60 km/h, HDC enters a standby state. When the vehicle speed exceeds 60 km/h, HDC is turned off.

### 7.7.11 Hill start assist (HHC)

## 7. Driving

When Autohold is not activated, and the vehicle brakes on a slope greater than 5%, the vehicle's brake system will automatically maintain approximately 1.5 s of braking force. During this 1.5 s, pressing the accelerator pedal will correspondingly reduce the braking force to ensure sufficient time to help the vehicle start.

### Warning

- HHC can only prevent the vehicle from sliding downhill for a short time. The driver is responsible for controlling the vehicle, monitoring the system's operation, and intervening when necessary.

### Tip

Before driving, please do not place heavy objects on the seat to avoid false alarm of the system.

### 7.7.12 Coordinated regenerative braking system (CRBS)

During driving, when the vehicle speed is above 12 km/h and the vehicle brakes, the coordinated regenerative braking system (CRBS) will automatically control the front and rear motors to recover energy. CRBS can both recover energy and provide a certain amount of electric braking force.

You can set the energy recovery level by clicking the "Vehicle Settings → Vehicle → Driving → Energy Recovery" icon through the central control screen. This car provides three levels of recovery: low, medium and high. You can set the energy recovery level according to your driving habits.

## 7.8 Fuel oil and charging

### 7.8.1 Refuel

#### I. Before refueling

This vehicle can only be refueled with unleaded gasoline of 95# and above.

#### II. Open the fuel cap

1. Click the "Fuel" icon on the side of the central control screen to unlock the tank cap.

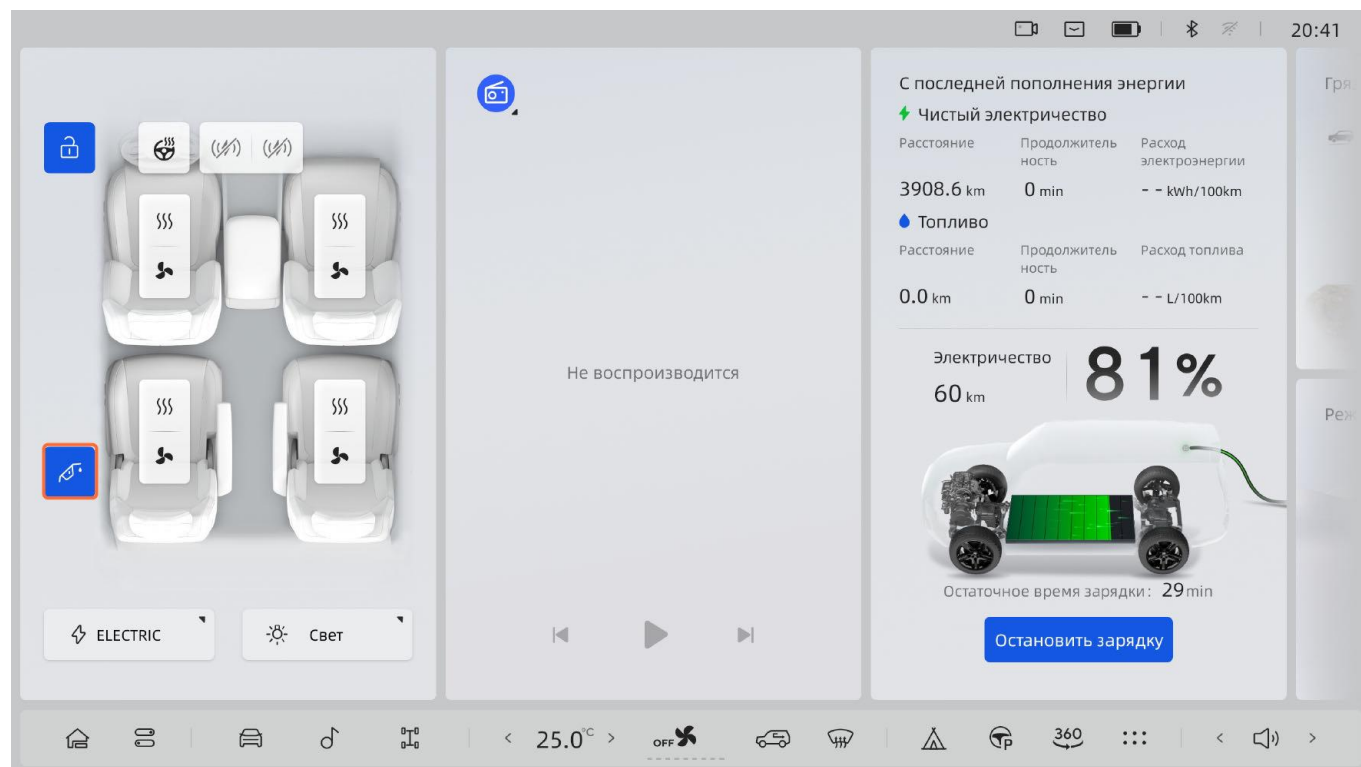

## 7. Driving

2. Press the edge of the fuel filler cap, then open the fuel filler cap with your hand.

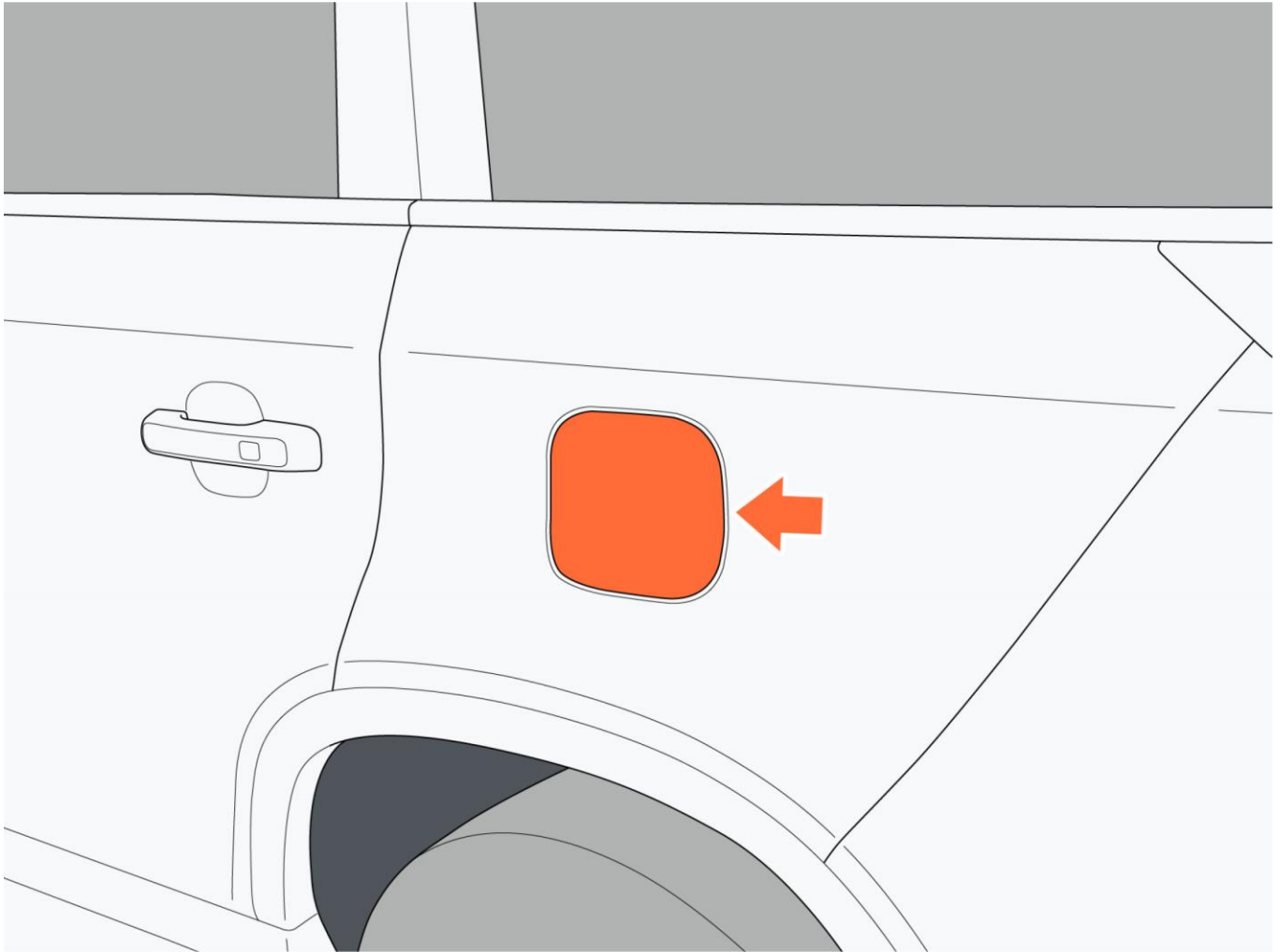

3. Unscrew the tank cap counterclockwise.

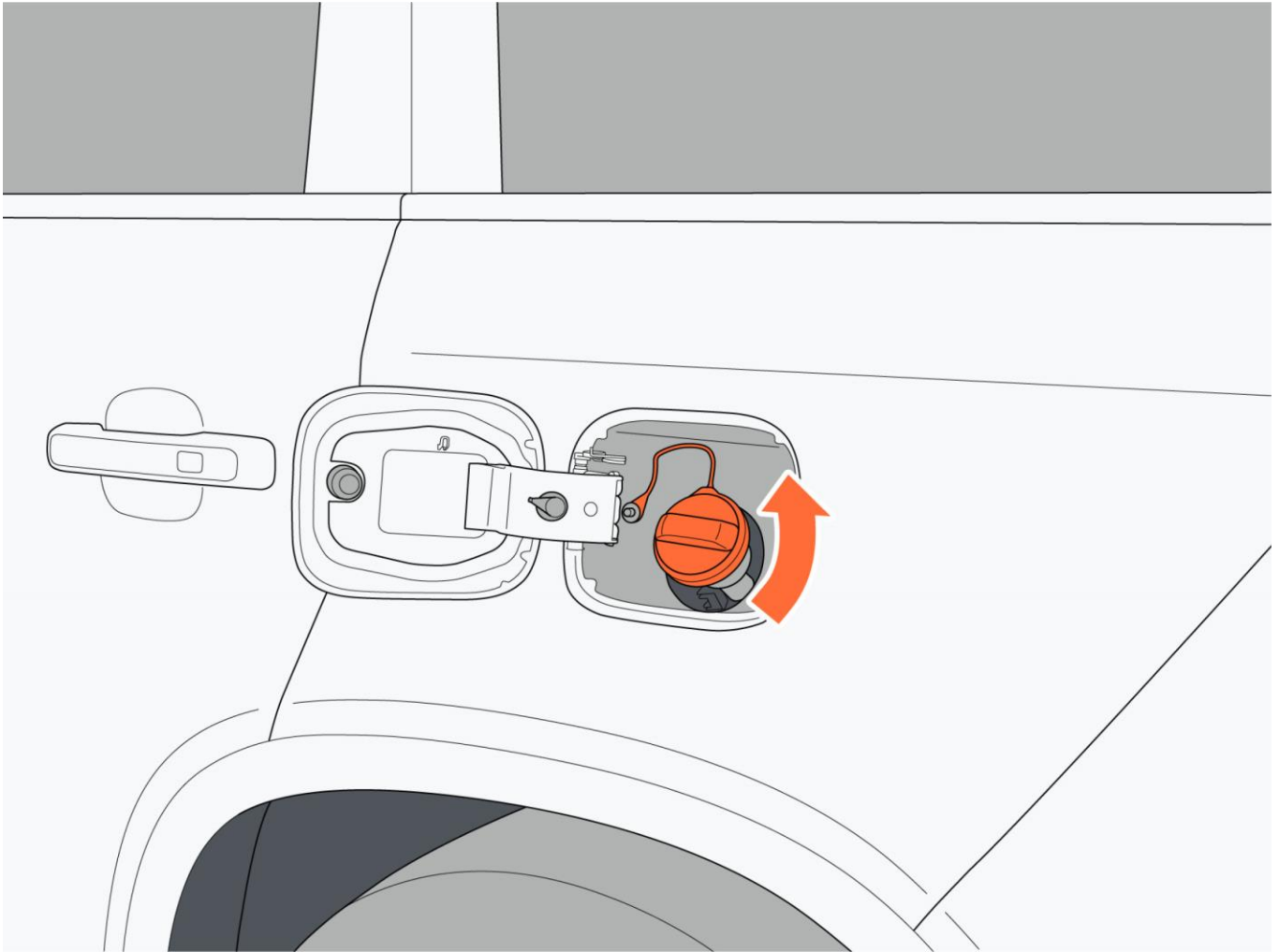

## 7. Driving

4. Hang the tank cap on the back of the fuel filler cap.

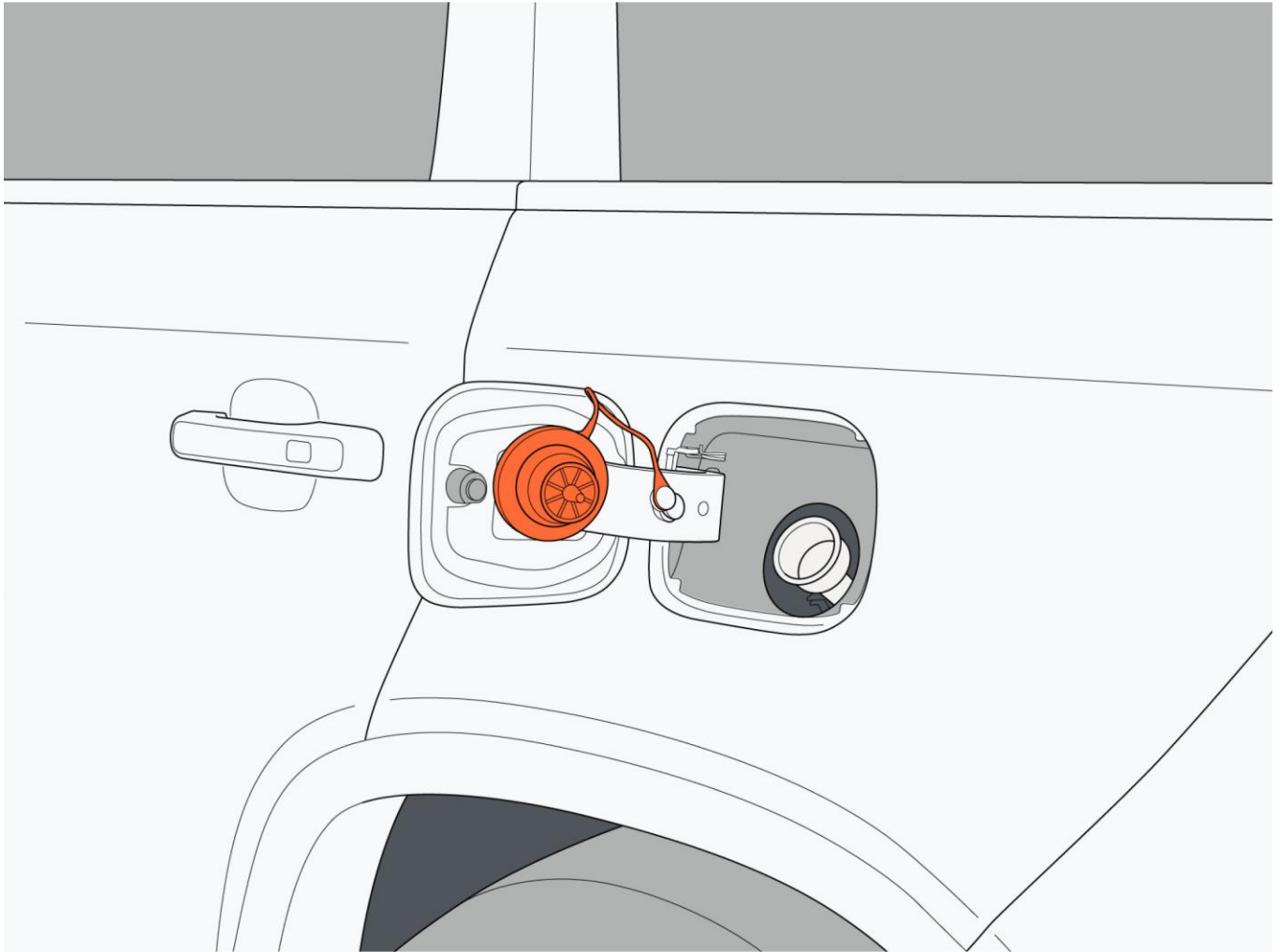

### III. Close the tank cap

1. After refueling, rotate the tank cap clockwise until you hear a click, then stop rotating.
2. Close the fuel filler cap until you hear a click.

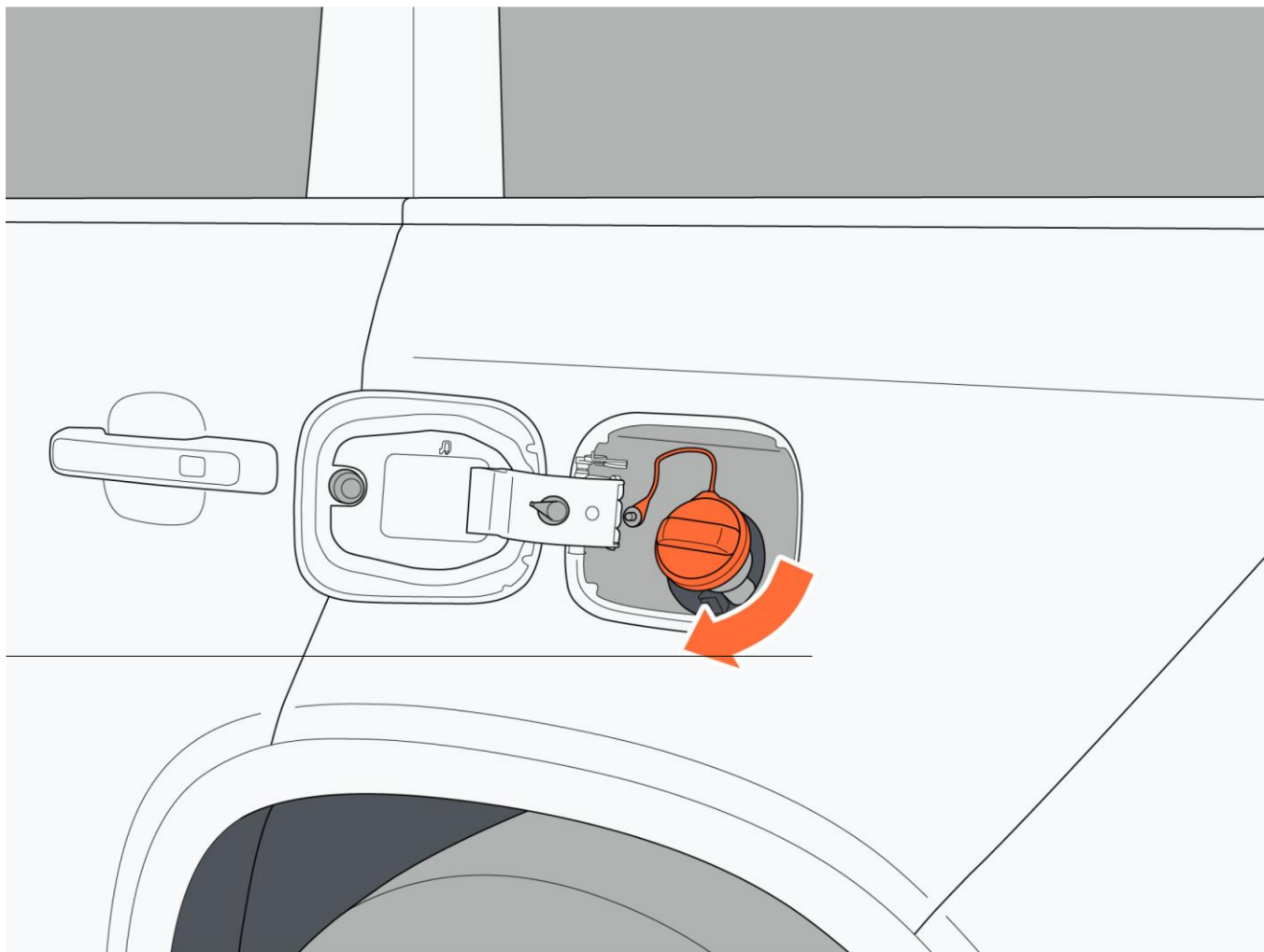

#### Warning

- Before refueling, please discharge your body's static electricity. Do not allow ungrounded personnel approach the fuel nozzle to avoid static electricity accumulation and igniting the fuel.
- Do not smoke; make phone calls while refueling to avoid causing a fire.
- Do not continue to refuel the tank after the fuel nozzle automatically shuts off.



## 7. Driving

### 7.8.2 Charging (Configuration 1)

#### I. Charging port

This car is equipped with an AC charging port:

1. Charging port.

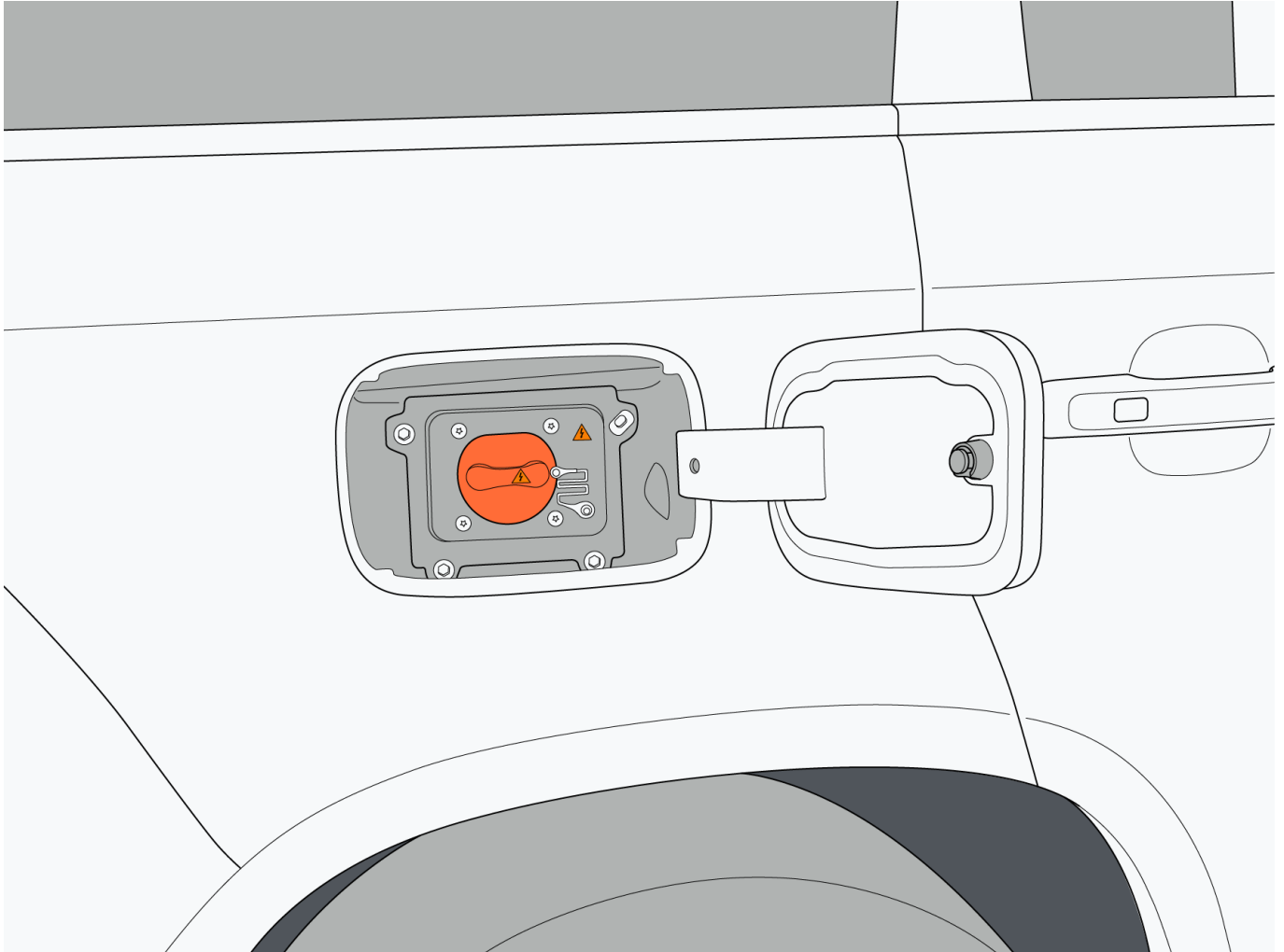

### II. Opening and closing the charging port cover

- • Opening: When the vehicle is in P gear and unlocked, press the back of the charging port cover to open it.

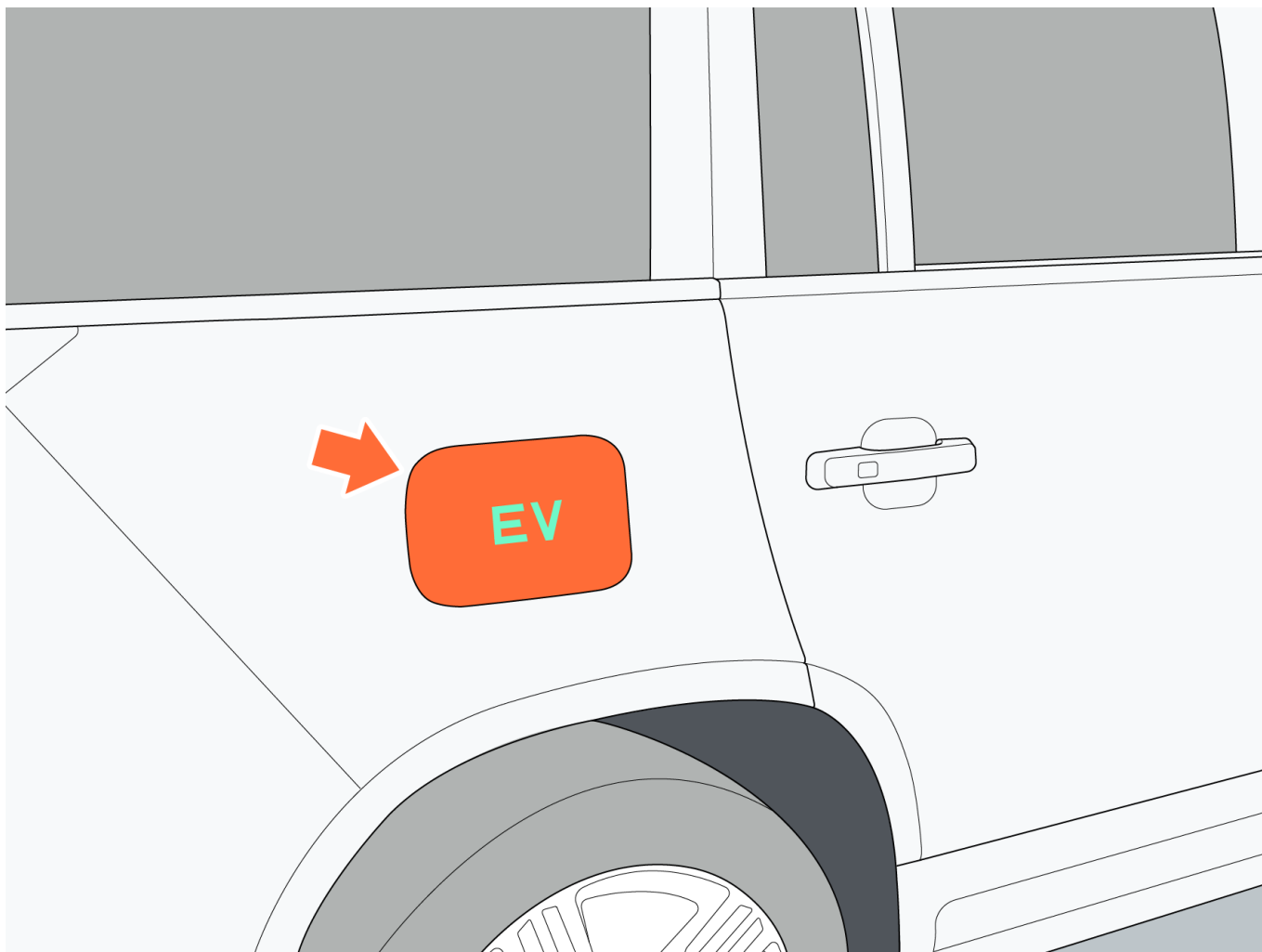

## 7. Driving

- Closing: After charging, cover the charging port dust cover, gently push the charging port cover until you hear a “click,” and the charging port cover is closed in place.

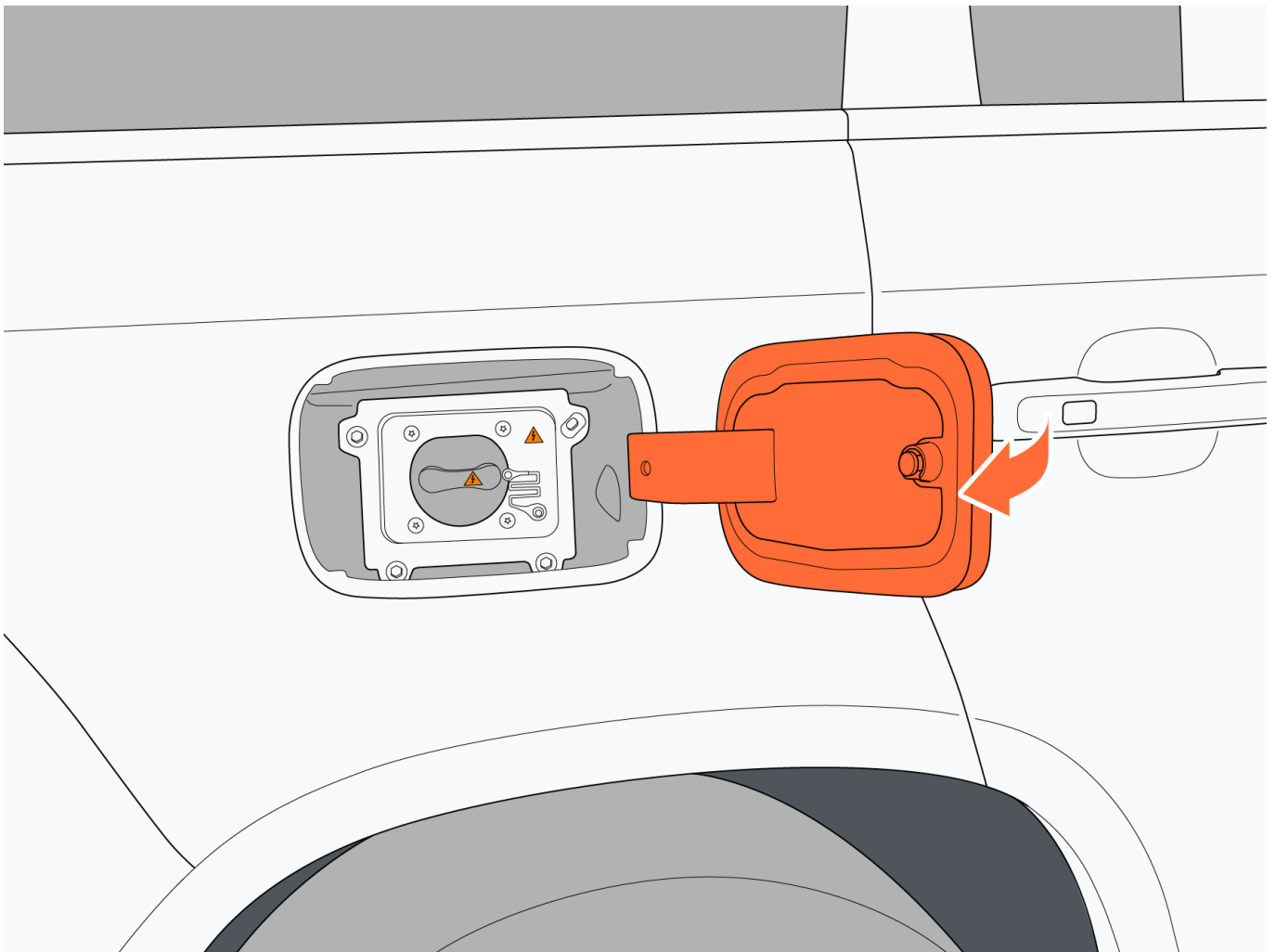

## III. Charging operation process

1. Switch the vehicle to P gear before charging.
2. Open the charging port cover, remove the charging port dust cover as needed.

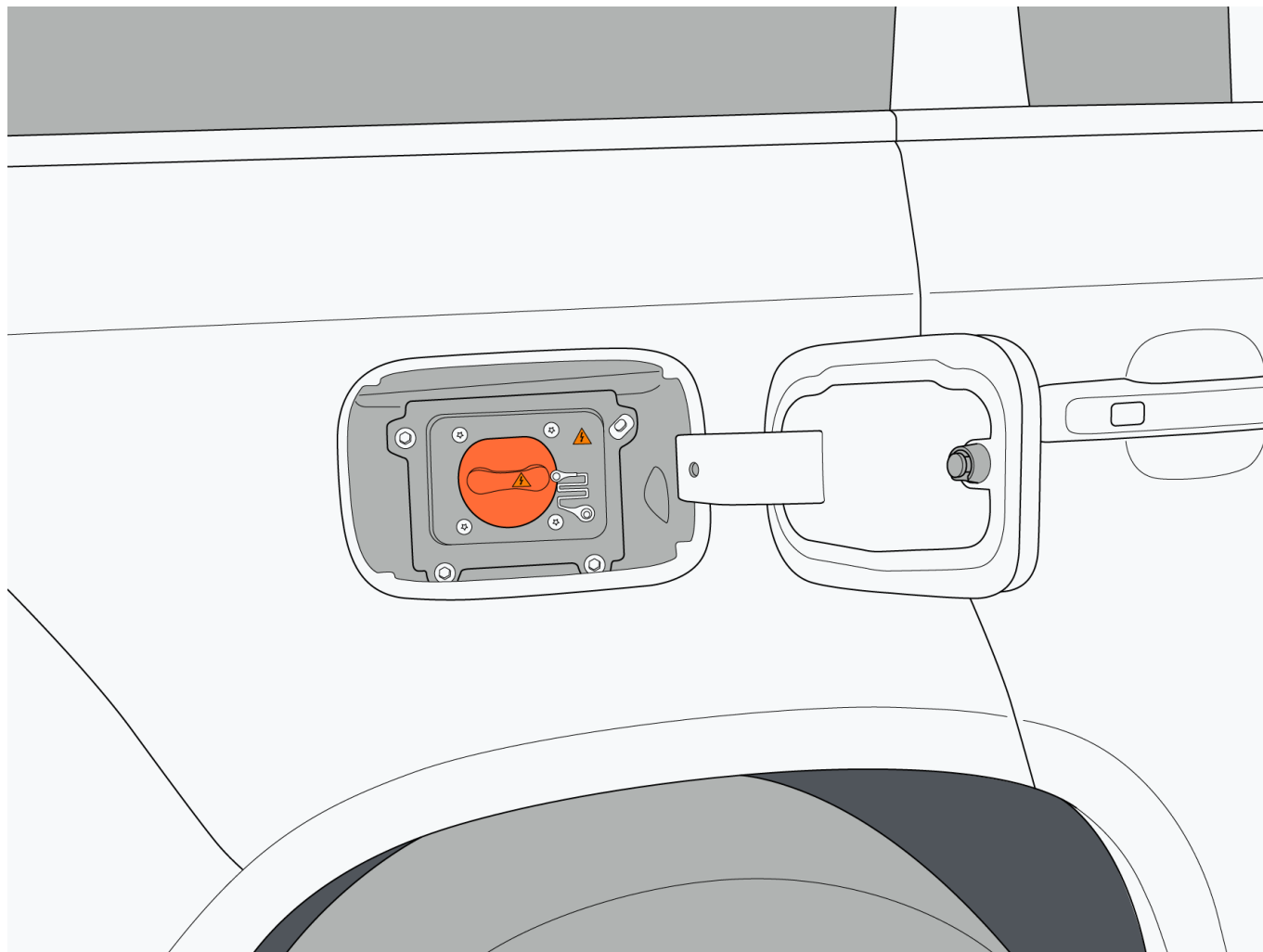

3. Before inserting the charger, please read the charging equipment operation guide and check if the charging device is in good condition, then connect the charger to the charging port. After the charger is connected, you can view the charging status through the central control screen.

- Common charging prompts on the central control screen:

Successful connection.

Charging

Charging completed

## IV. Charging insulation

After enabling battery insulation, when the vehicle is fully charged, the terminal station will be used to continue insulation of the vehicle battery to ensure the driving experience.

In the charging management interface, click "Battery Insulation" to enable or disable battery insulation.

**i** Tip

- Using the charging insulation function will incur a small amount of cost.

# 7. Driving

## V. Parking power generation

When the vehicle power is low, use the parking power generation function. The range extender is started to charge the battery.

Click "Parking Power Generation" through the charging control interface to turn on or off the parking power generation function.

When using the parking power generation function, the following requirements must be met:

- The vehicle is in P gear.
- The battery level is less than 80%.
- The charger is not inserted.
- The front engine compartment is closed.

When using the parking power generation function, it can be turned off manually. Or it can be turned off automatically in any of the following situations:

- The charger is connected.
- The vehicle is not in P gear.
- The battery level has reached 80%.
- The vehicle is locked.
- There is no enough fuel.

### Caution

- When using parking power generation, please park the vehicle in a safe area to avoid safety accidents.

## VI. Remove the charger

Unplug the charger

- After charging is complete, the vehicle will automatically unlock the charger, and it can be unplugged directly.
- If it is necessary to stop charging during the charging process, click "Stop Charging" in the charging management interface or unlock the charger by pressing the unlocking button on the remote key.

## VII. Charging setting

1. Reservation charging: In the charging management interface, click "Reservation Charging" to set it to turn on or off reserving charging. When reservation charging is enabled, click the option under the "Reserved Time" to set the start time for reservation charging.
2. Charging limit: In the charging management interface, slide the slider under "Charging Limit" to set the charging limit for the power battery (setting range: 80% ~ 100%).
3. Stop charging: In the charging management interface, click the "Stop Charging" icon to stop charging.
4. Start Charging: In the charging management interface, click the "Start Charging" icon to start charging.

## VIII. Charging information

If using a 7 kW AC charging station, the battery can be fully charged in about 8 h and 30 min. If using an 11 kW AC charging station, the battery can be fully charged in about 6 h.

### IX. Charger locking/unlocking

The locking/unlocking strategy of the electronic lock is based on the relevant requirements of IEC 61851 for electronic locks. When the charger is inserted into the charging port, the charging port locks the charger with an electronic locking device (electronic lock) to ensure charging safety.

#### 1. Automatic locking/unlocking

During charging, the electronic lock automatically locks.

After charging is complete, the electronic lock automatically unlocks.

If you need to remove the charger during charging or waiting for reservation charging, please first unlock the vehicle and remove the charger within 30s. Otherwise, the electronic lock on the charging port will be re-locked.

#### 2. Emergency unlock

If the electronic lock fails and cannot unlock the charging port, unlock it by pulling the emergency unlock handle.

- Open the trunk door and remove the luggage compartment mat.
- After removing the luggage compartment mat, take out the toolbox from the trunk and pull the emergency unlock handle to unlock the electronic lock of the charging port.

## 7. Driving

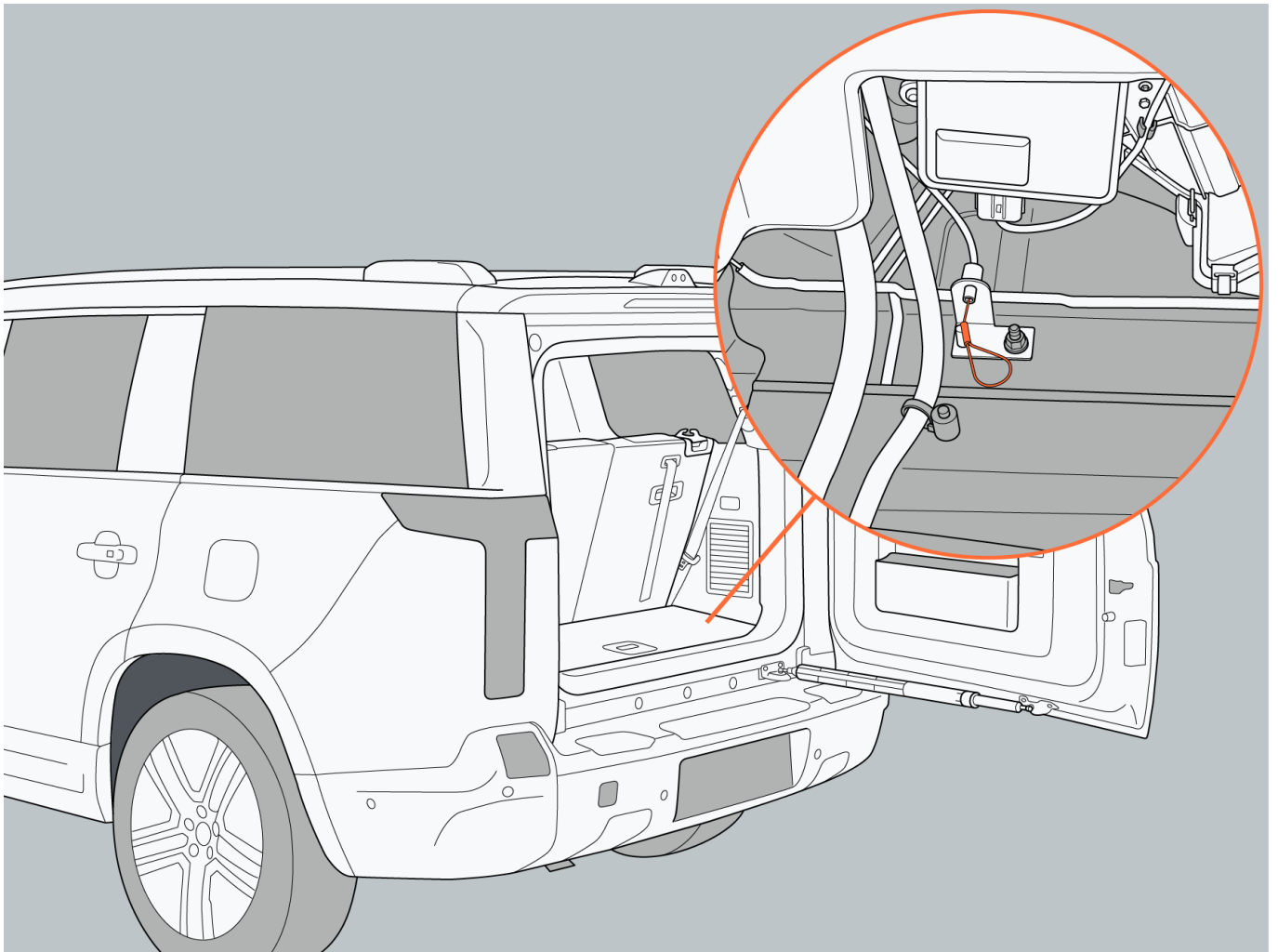

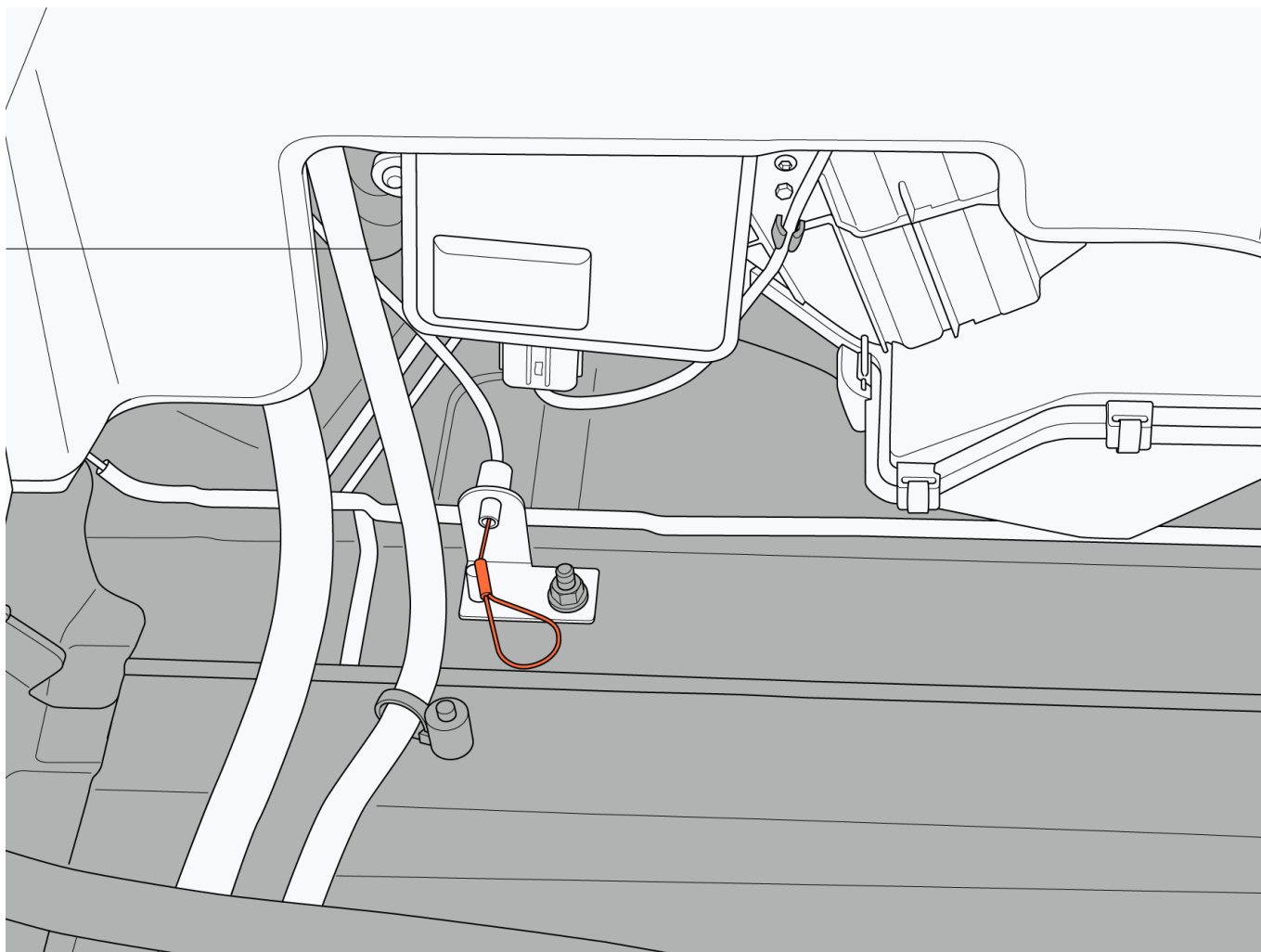

**Warning**

- If the pure electric range displayed on the instrument panel drops to 0, it must be charged within 24 h. If it is not charged within 7 days, it may cause permanent damage to the battery. If the vehicle cannot be charged, please contact the ROX Service Center immediately.
- Do not charge when the charging equipment is damaged, rusted, damp, or has foreign objects, to avoid electric shock.
- Do not wash the charging port area while charging, to avoid damage to the vehicle or charging equipment.
- Do not forcefully pull out the plug while charging, as this may cause damage to the vehicle or charging equipment, or even electric shock.
- It may affect medical or implantable electronic devices when charging. Consult the manufacturer of the electronic device before charging.
- Do not touch the metal terminals inside the charger or charging port, to avoid electric shock.
- Do not touch a malfunctioning charging station. If there is an abnormality, press the emergency stop switch immediately and contact a professional as soon as possible.



## 7. Driving

- Before charging, ensure that there is no water or foreign objects in the charging port and charging connector port, and that the metal terminals are not damaged or affected by rust or corrosion. If any, do not charge. Abnormal terminal connection may cause short circuits or electric shock, resulting in hazarding to personal life.
- After charging, do not disconnect the charger with wet hand or when you stand in the water, as this may cause the electric shock and the personal injury.
- If you find any abnormalities with the vehicle or charging equipment during charging, please stop charging immediately.
- When there is thunderstorm weather, it is recommended not to charge the vehicle as lightning strikes may cause damage to the vehicle and charging equipment, resulting in personal injury.
- Ensure that the charging equipment is disconnected from the charging port before driving the vehicle.

### Caution

- Non-standard charging equipment may not be able to charge the vehicle.
- If the vehicle is locked while charging, the charger cannot be removed. It needs to unlock the vehicle or stop charging before the charger can be removed.
- Charging with the A/C system turned on will extend the charging time.
- In winter or in cold weather areas, charging time will be extended.
- The cooling fan will automatically turn on to cool the battery during charging, which is a normal phenomenon.

### Tip

- When charging, use standard charging station equipment, and charge correctly according to the charging station instructions.
- The charging environment should be dry and ventilated, and there are no flammable and explosive items around.
- It is recommended to charge the vehicle at least once every two weeks until it is fully charged.
- When the vehicle battery drops below 20%, it needs to be charged for maintenance. If the low battery warning light in the car is on, it indicates that the power battery is about to run out. Please charge the battery in time; otherwise, it may affect the service life of the power battery.
- When the ambient temperature is low, the charging time will be extended, which is a normal phenomenon.
- To ensure the best performance of the battery, the system automatically adjusts the charging current according to temperature changes.

### 7.8.3 Charging (Configuration 2)

#### I. Charging port

This car is equipped with two charging interfaces: fast charging and slow charging

- Fast charging interface.
- Slow charging interface.

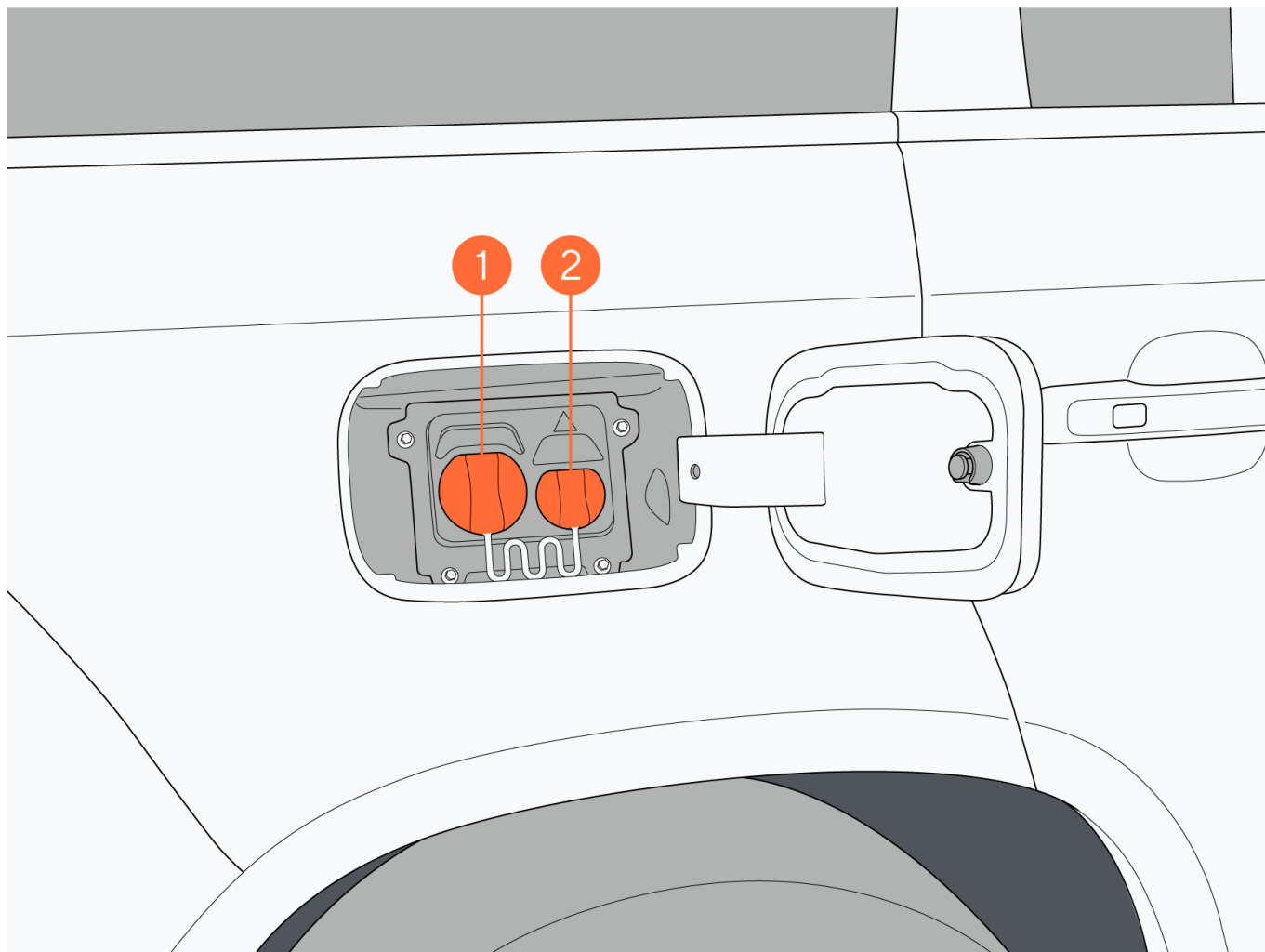

#### II. Charging indicator light

The charging indicator light is located at the charging interface.

Indicator color at the charging port	Status	Color meaning
White	Normal lighting	Ready, but charger/discharger not inserted
Blue	Flash	Connecting with charging/discharging equipment communication

## 7. Driving

	Normal lighting	Charger/discharger inserted or waiting for reservation charging
Green	Flash	Charging or discharging
	Normal lighting	Charging completed or discharging completed
Orange	Normal lighting	charger/discharger is not fully inserted
Red	Normal lighting	Charge/discharge failure, charging stopped

### III. Opening and closing the charging port cover

- Opening: When the vehicle is in P gear and unlocked, press the back of the charging port cover to open it.

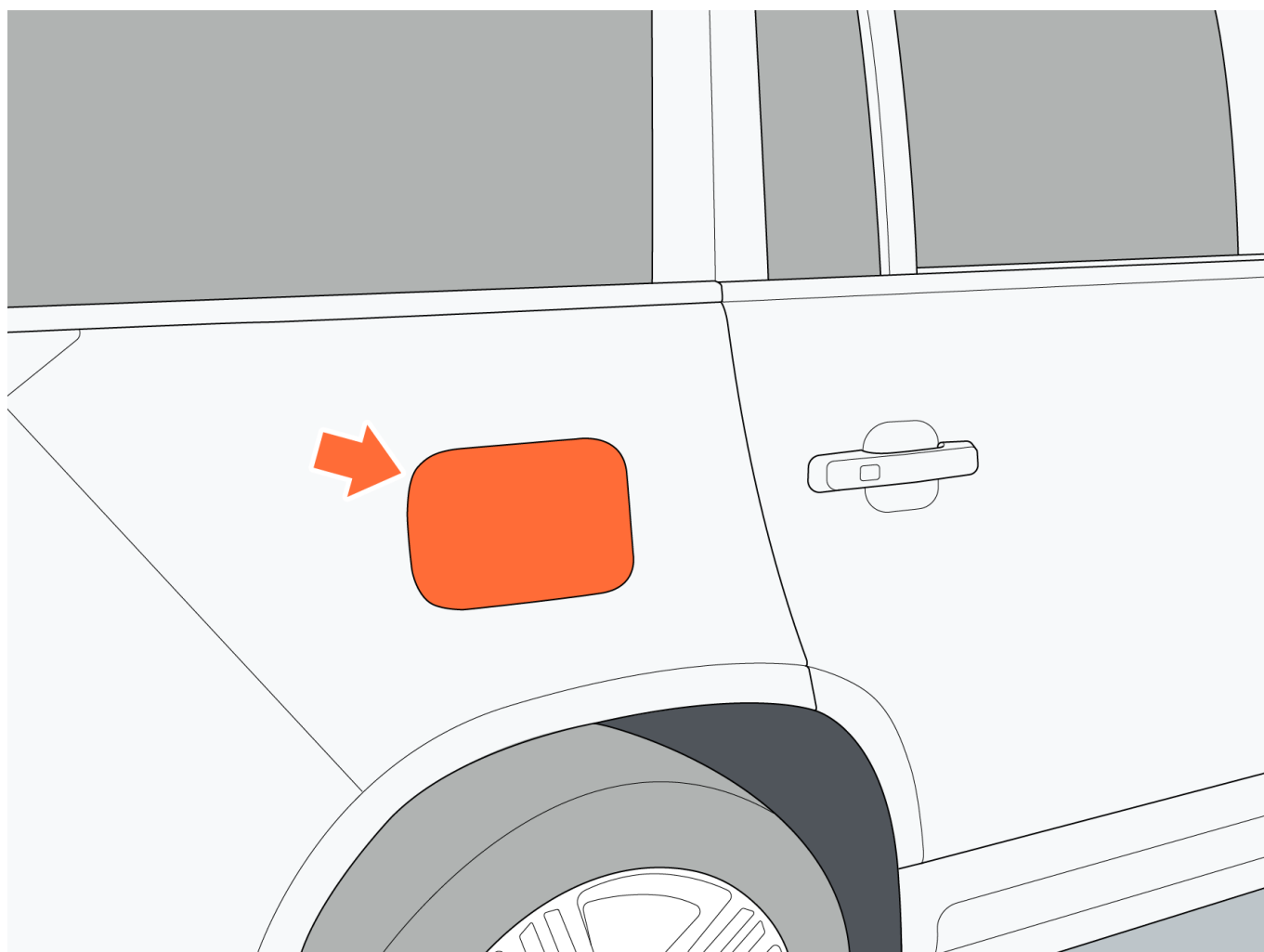

- Closing: After charging, cover the charging port dust cover, gently push the charging port cover until you hear a “click,” and the charging port cover is closed in place.

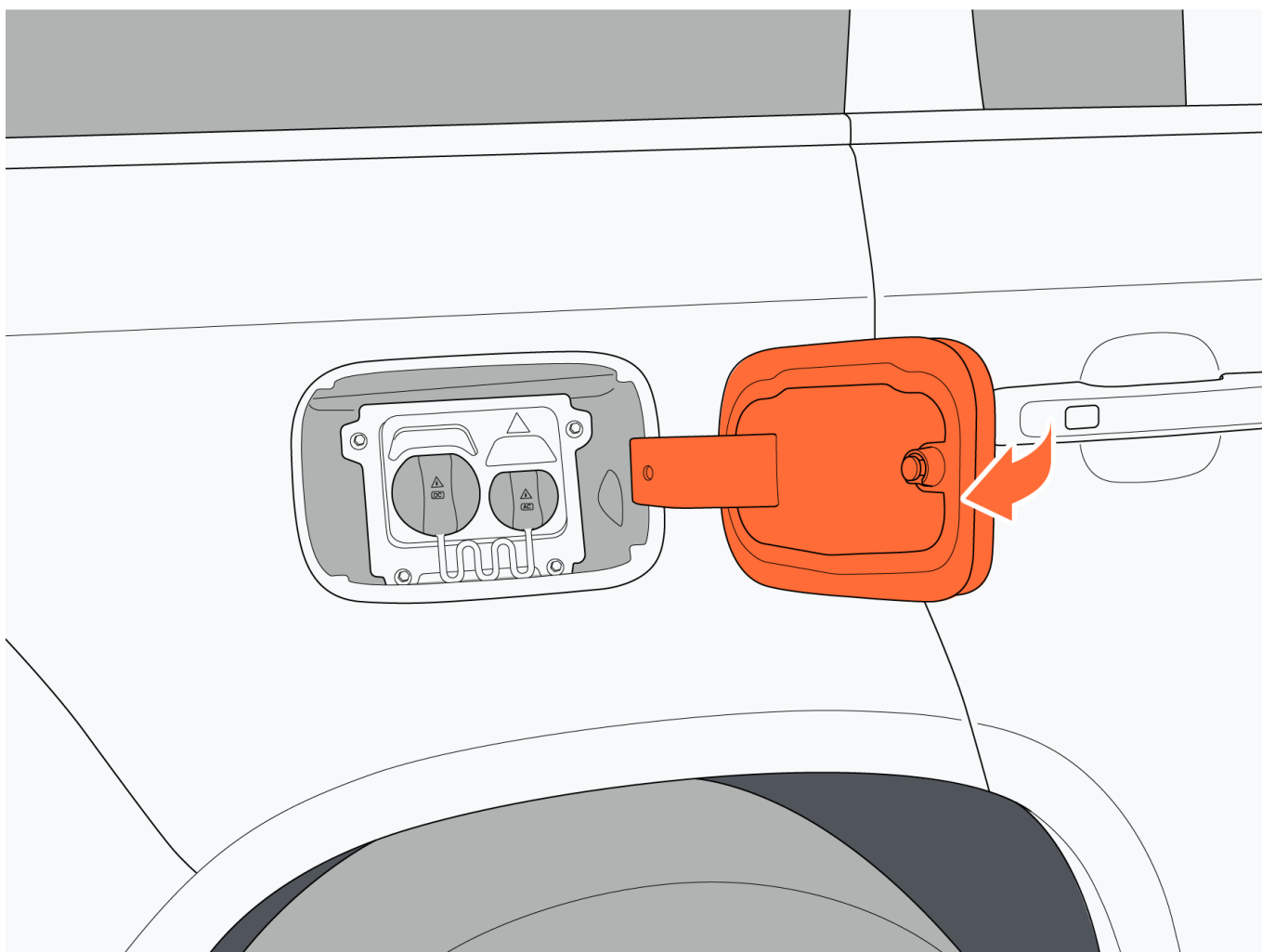

#### IV. Charging operation process

1. Switch the vehicle to P gear before charging.
2. Open the charging port cover, remove the dust cover of fast/slow charging port as needed.
  - If using fast charging (DC charging), please remove the fast charging dust cover 1.
  - If using slow charging (AC charging), please remove the slow charging dust cover 2.

## 7. Driving

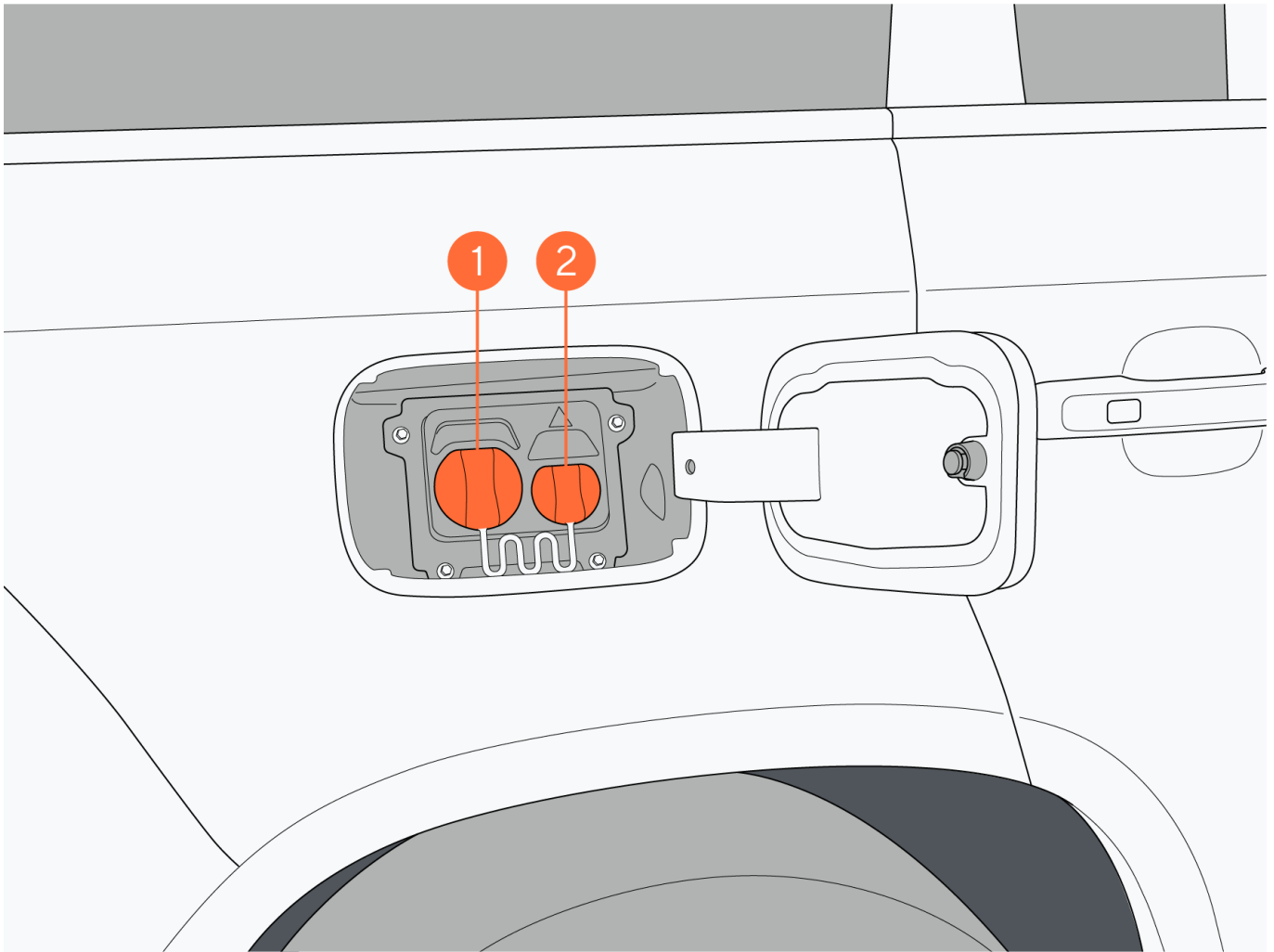

3. Before inserting the charger, please read the charging equipment operation guide and check if the charging device is in good condition, then connect the charger to the charging port. After the charger is connected, you can view the charging status through the central control screen.

- Common charging prompts on the central control screen:

Successful connection.

Charging

Charging completed

V. Charging insulation

After enabling battery insulation, when the vehicle is fully charged, the terminal station will be used to continue insulation of the vehicle battery to ensure the driving experience.

In the charging management interface, click "Battery Insulation" to enable or disable battery insulation.



Tip

- Using the charging insulation function will incur a small amount of cost.

VI. Parking power generation

When the vehicle power is low, use the parking power generation function. The range extender is started to charge the battery.

Click "Parking Power Generation" through the charging control interface to turn on or off the parking power generation function.

When using the parking power generation function, the following requirements must be met:

- The vehicle is in P gear.
- The battery level is less than 80%.
- The charger is not inserted.
- The front engine compartment is closed.

When using the parking power generation function, it can be turned off manually. Or it can be turned off automatically in any of the following situations:

- The charger is connected.
- The vehicle is not in P gear.
- The battery level has reached 80%.
- The vehicle is locked.
- There is no enough fuel.

### Caution

- When using parking power generation, please park the vehicle in a safe area to avoid safety accidents.

### VII. Remove the charger

#### Unplug the charger

- After slow charging is complete, the vehicle will automatically unlock the charger, and it can be unplugged directly.
- If it is necessary to stop charging during the slow charging process, click "Stop Charging" in the charging management interface or unlock the charger by pressing the unlocking button on the remote key.
- During or after the fast charging process, the charger can only be removed after the fast charging station stops charging.

### VIII. Charging setting

1. Reservation charging: In the charging management interface, click "Reservation Charging" to set it to turn on or off reserving charging. When reservation charging is enabled, click the option under the "Reserved Time" to set the start time for reservation charging.
2. Charging limit: In the charging management interface, slide the slider under "Charging Limit" to set the charging limit for the power battery (setting range: 80% ~ 100%).
3. Stop charging: In the charging management interface, click the "Stop Charging" icon to stop charging.
4. Start Charging: In the charging management interface, click the "Start Charging" icon to start charging.

### IX. Charging information

## 7. Driving

Slow charging: Using a 7kW AC charging station, the battery can be fully charged in about 8 h and 30 min; Using an 11 kW AC charging station, the battery can be fully charged in about 6 h.

Fast charging: Using a 100kW DC charging station, the battery can be charged from 30% to 80% in about 30 min.

### X. Charger(slow charging) locking/unlocking

The locking/unlocking strategy of the electronic lock(slow charging) is based on the relevant regulation of electronic locks. When the charger is inserted into the charging port, the charging port locks the charger with an electronic locking device (electronic lock) to ensure charging safety.

#### 1. Automatic locking/unlocking

During charging, the electronic lock automatically locks.

After charging is complete, the electronic lock automatically unlocks.

If you need to remove the charger during charging or waiting for reservation charging, please first unlock the vehicle and remove the charger within 30s. Otherwise, the electronic lock on the charging port will be re-locked.

#### 2. Emergency unlock

If the electronic lock fails and cannot unlock the slow charging port, unlock it by pulling the emergency unlock handle.

- Open the trunk door and remove the luggage compartment mat.
- After removing the luggage compartment mat, take out the toolbox from the trunk and pull the emergency unlock handle to unlock the electronic lock of the charging port.

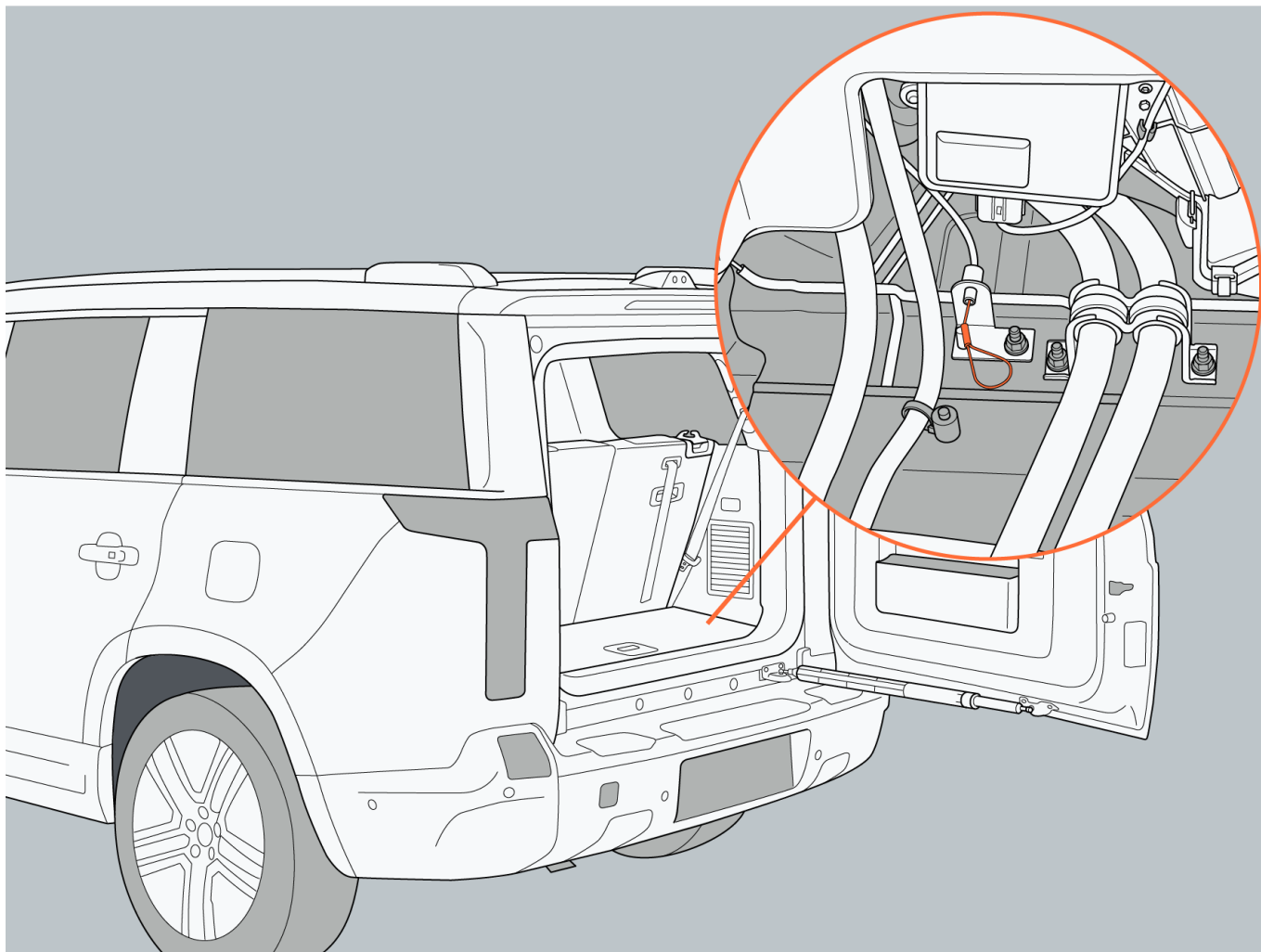



## 7. Driving

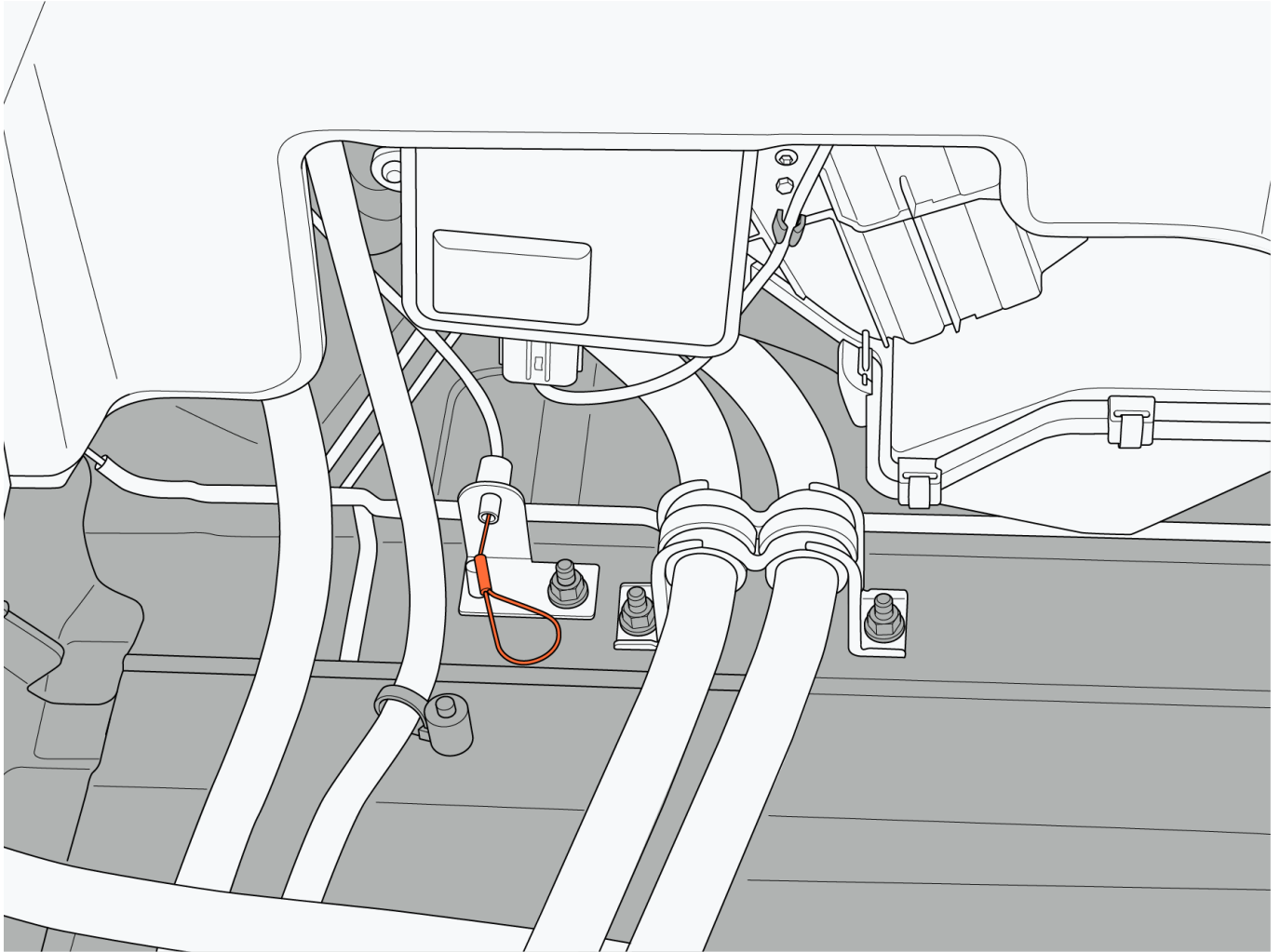

### Warning

- If the pure electric range displayed on the instrument panel drops to 0, it must be charged within 24 h. If it is not charged within 7 days, it may cause permanent damage to the battery. If the vehicle cannot be charged, please contact the ROX Service Center immediately.
- Do not charge when the charging equipment is damaged, rusted, damp, or has foreign objects, to avoid electric shock.
- Do not wash the charging port area while charging, to avoid damage to the vehicle or charging equipment.
- Do not forcefully pull out the plug while charging, as this may cause damage to the vehicle or charging equipment, or even electric shock.
- It may affect medical or implantable electronic devices when charging. Consult the manufacturer of the electronic device before charging.
- When charging, it is necessary to ensure that the other charging port without a charger is always protected by the dust cover to prevent dust or sand from entering and causing wear on the terminals, thereby affecting the service life of the vehicle and charging equipment.
- Do not touch the metal terminals inside the charger or charging port, to avoid electric shock.
- Do not touch a malfunctioning charging station. If there is an abnormality, press the emergency

stop switch immediately and contact a professional as soon as possible.

- Before charging, ensure that there is no water or foreign objects in the charging port and charging connector port, and that the metal terminals are not damaged or affected by rust or corrosion. If any, do not charge. Abnormal terminal connection may cause short circuits or electric shock, resulting in hazardous to personal life.
- After charging, do not disconnect the charger with wet hand or when you stand in the water, as this may cause the electric shock and the personal injury.
- If you find any abnormalities with the vehicle or charging equipment during charging, please stop charging immediately.
- When there is thunderstorm weather, it is recommended not to charge the vehicle as lightning strikes may cause damage to the vehicle and charging equipment, resulting in personal injury.
- Ensure that the charging equipment is disconnected from the charging port before driving the vehicle.

### Caution

- Non-standard charging equipment may not be able to charge the vehicle.
- If the vehicle is locked while charging, the charger cannot be removed. It needs to unlock the vehicle or stop charging before the charger can be removed.
- Charging with the A/C system turned on will extend the charging time.
- In winter or in cold weather areas, charging time will be extended.
- The cooling fan will automatically turn on to cool the battery during charging, which is a normal phenomenon.

### Tip

- When charging, charging station equipment that meets national standards should be used, and charging should be carried out correctly according to the instructions of the charging station
- The charging environment should be dry and ventilated, and there are no flammable and explosive items around.
- Avoid frequent use of fast charging and try to choose AC slow charging stations for charging. It is recommended to use slow charging at least once every two weeks until the vehicle is fully charged before use.
- When the vehicle battery drops below 20%, it needs to be charged for maintenance. If the low battery warning light in the car is on, it indicates that the power battery is about to run out. Please charge the battery in time; otherwise, it may affect the service life of the power battery.
- When the ambient temperature is low, the charging time will be extended, which is a normal phenomenon.

## 7. Driving

- To ensure the best performance of the battery, the system automatically adjusts the charging current according to temperature changes.

### 7.8.4 External discharge (Configuration 1)

The external discharge function can output the electricity stored in the power battery at 220V, supplying external appliances with a maximum power of 3,500W.

#### I. Discharge port

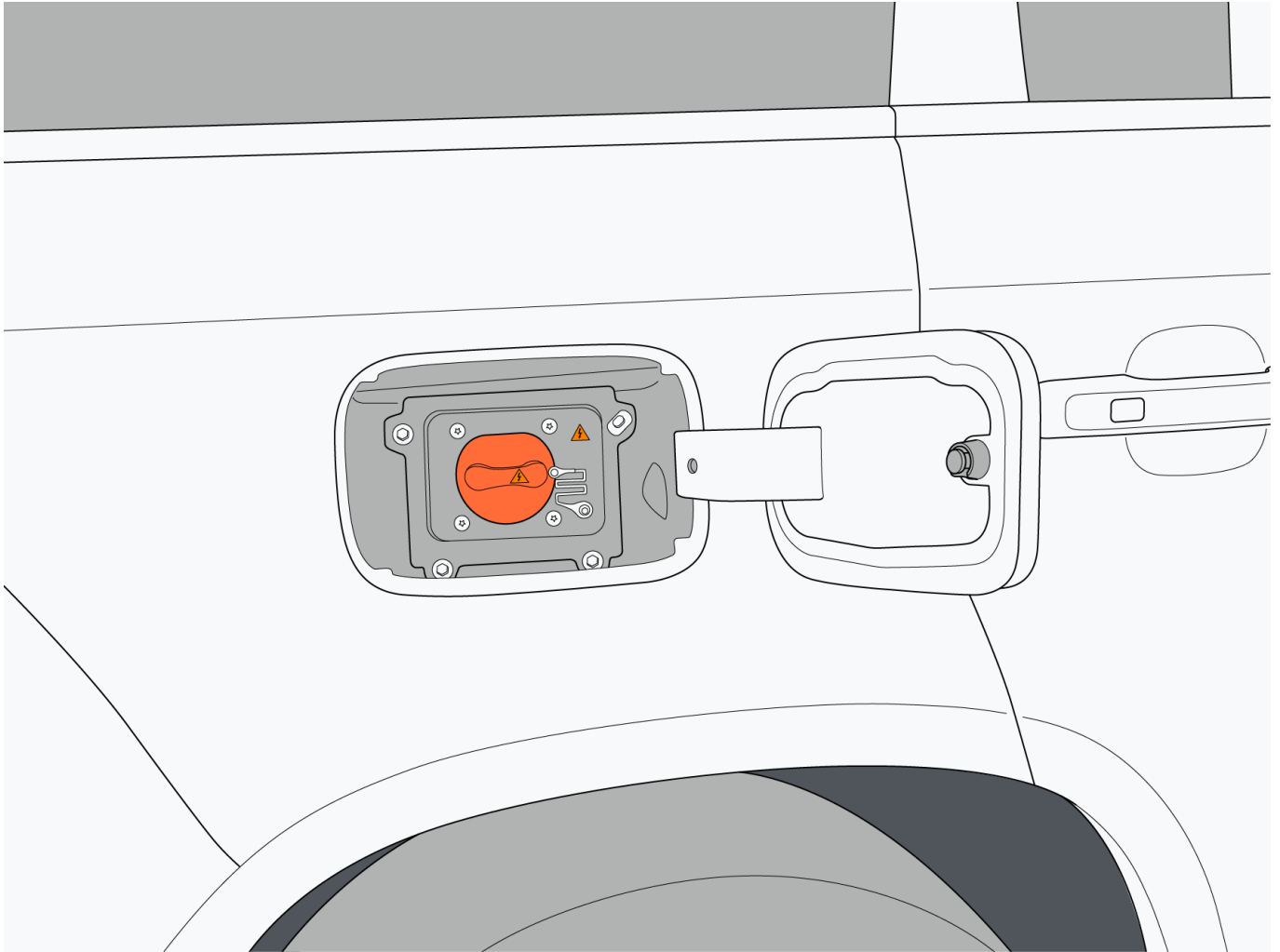

#### II. Start or stop discharging

##### 1. Start discharging

After inserting the converter, enter the discharge management interface. In the discharge management interface, you can set the lower limit of discharge, check the connection status of the converter, vehicle mileage and other information.

If the converter is not inserted, the discharge management interface will prompt "Please insert the converter."

After inserting the converter, the "Start Discharge" icon will be highlighted. Click the "Start Discharge" icon to start external power supply.

Lower limit of discharge: The power battery will discharge to the set lower limit, after which the range extender will start, keeping the power battery level at the set lower limit. The vehicle will stop discharging when the fuel level reaches a low level.

### 2. Stop discharging

During external discharging, click the "Stop Discharge" icon to end external discharging.

#### Tip

- The converter and 220V socket can work simultaneously, but the maximum output power of each circuit should not exceed 3,500W. Otherwise, overload protection will stop the output.

### III. Install the converter

1. Open the charging port cover
2. Remove the charging port dust cover.

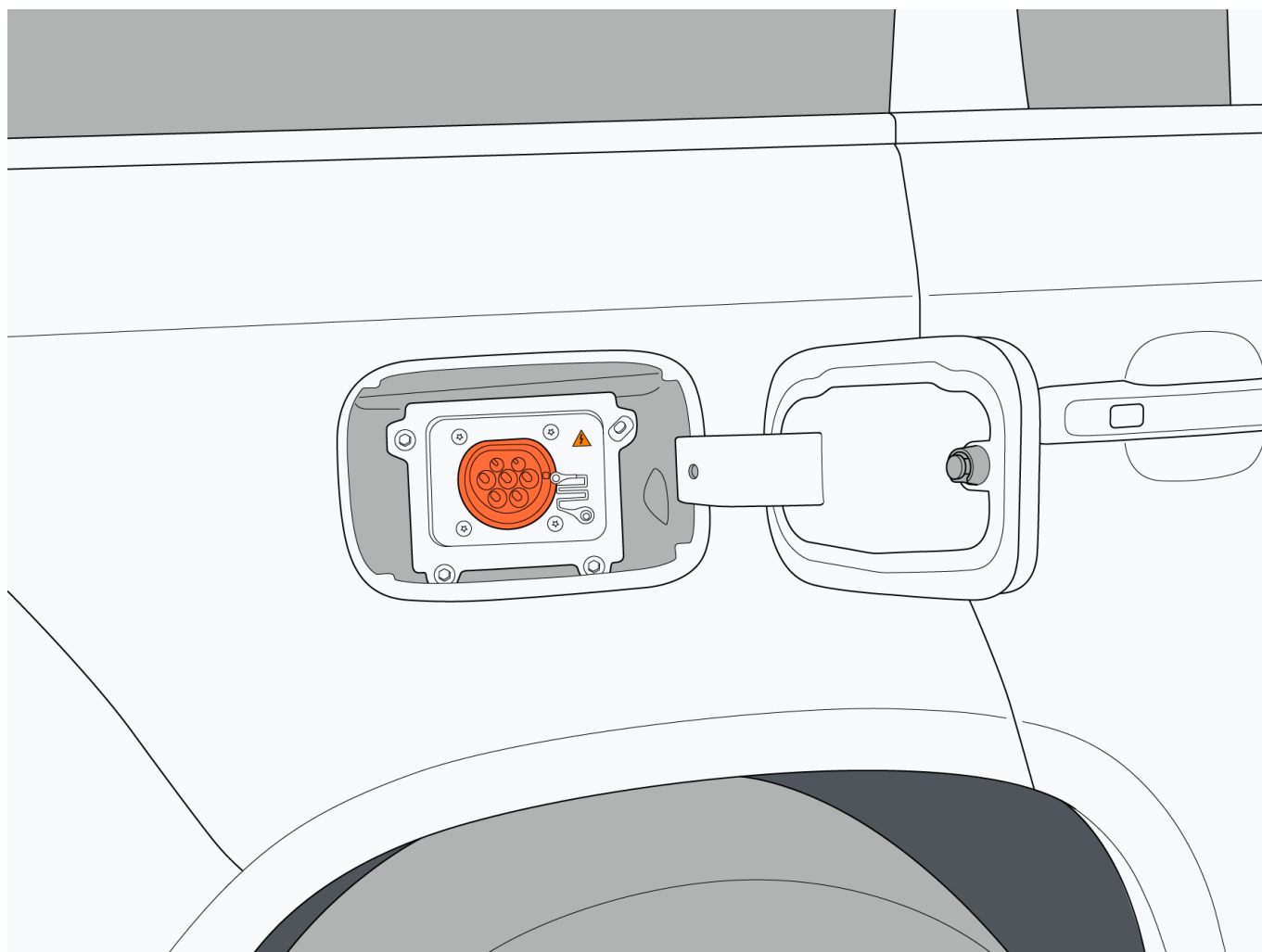

3. Check if the converter is damaged, and then insert the converter into the charging port. After the connection is successful, the discharge management interface will prompt "Successful Connection".

4. When the converter is successfully connected or the discharge is stopped, and there is no abnormality in the discharge system, click the "Start Discharge" button on the control screen to start the external discharge.

### IV. Remove the converter

## 7. Driving

1. In the discharge management interface, click “Stop Discharge” or the power supply has ended.
2. Unplug the converter, install the charging port dust cover, and close the charging port cover.

### Warning

- Do not discharge when the converter is damaged, rusted, damp, or has foreign objects, to avoid electric shock.
- Do not forcefully pull out the converter while discharging, as this may cause damage to the equipment or vehicle, or even electric shock.
- If there are any abnormalities during discharging, please stop the discharging.
- Do not discharge when the discharger head or the charging port is deformed, blackened or ablated.
- Do not discharge when there are obvious water stains in the charging port, to avoid damage to the vehicle or discharge equipment, or even electric shock.
- Do not touch the plug pins and adapter sockets of the load device.

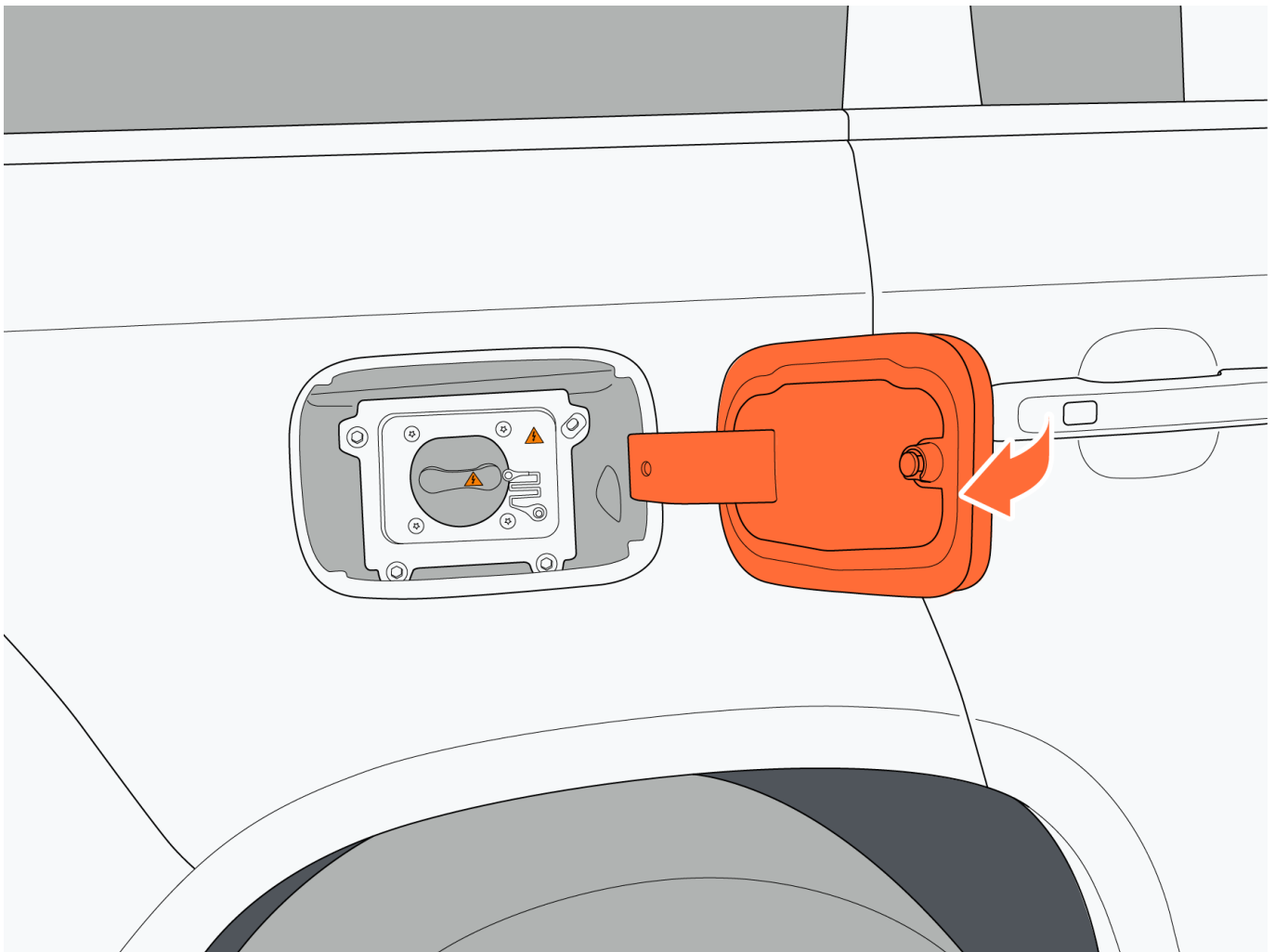

### 7.8.5 External discharge (Configuration 2)

The external discharge function can output the electricity stored in the power battery at 220V, supplying external appliances with a maximum power of 2,200W.

### I. Discharge port

The discharge interface is a slow charging interface.

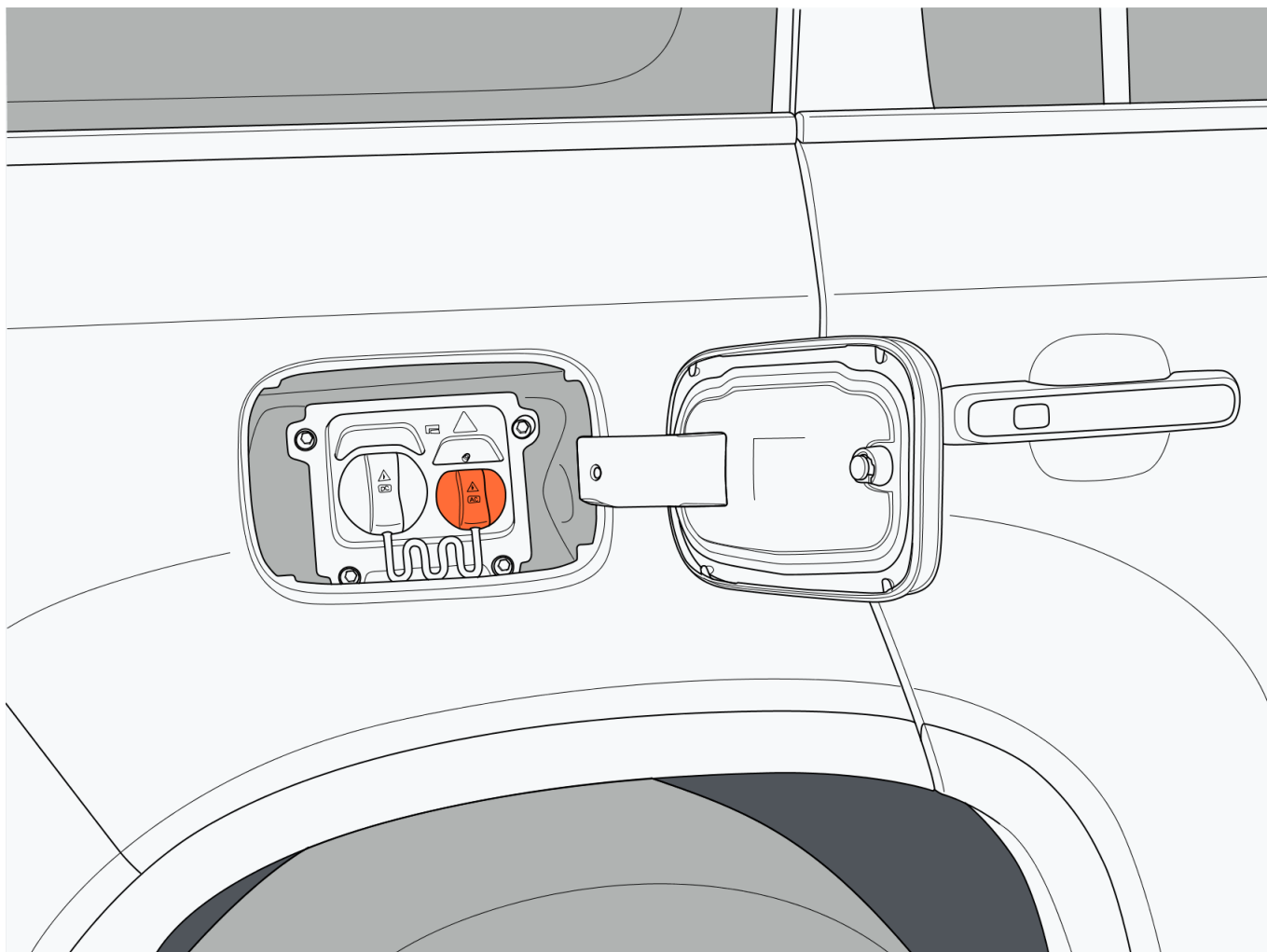

### II. Start or stop discharging

#### 1. Start discharging

After inserting the converter, enter the discharge management interface. In the discharge management interface, you can set the lower limit of discharge, check the connection status of the converter, vehicle mileage and other information.

If the converter is not inserted, the discharge management interface will prompt "Please insert the converter."

After inserting the converter, the "Start Discharge" icon will be highlighted. Click the "Start Discharge" icon to start external power supply.

Lower limit of discharge: The power battery will discharge to the set lower limit, after which the range extender will start, keeping the power battery level at the set lower limit. The vehicle will stop discharging when the fuel level reaches a low level.

#### 2. Stop discharging

## 7. Driving

During external discharging, click the "Stop Discharge" icon to end external discharging.

### **i** Tip

- The converter and 220V socket can work simultaneously, but the maximum output power of each circuit should not exceed 2,200W. Otherwise, overload protection will stop the output.

### III. Install the converter

1. Open the charging port cover
2. Remove the slow charging port dust cover.

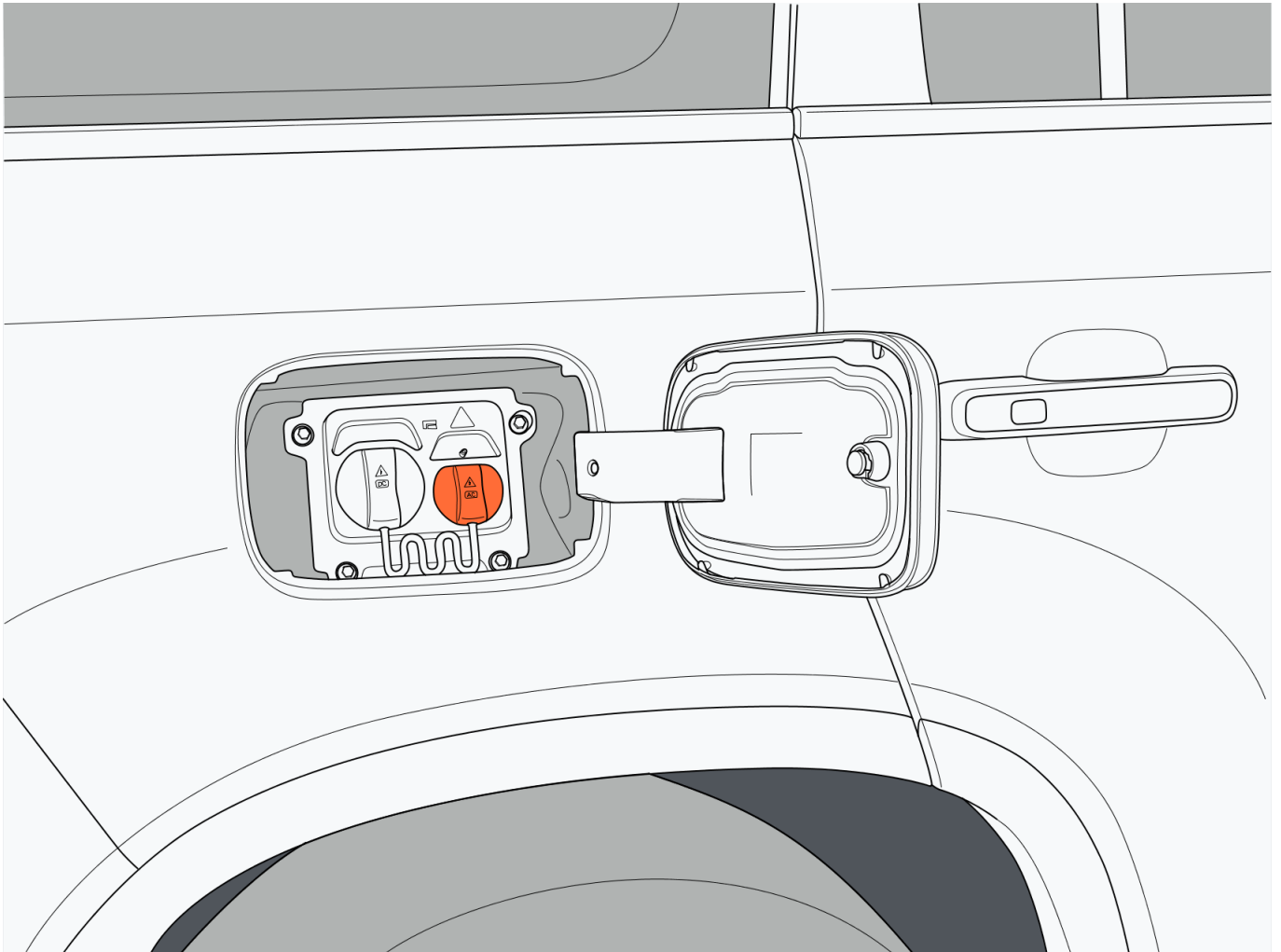

3. Check if the converter is damaged, and then insert the converter into the charging port. After the connection is successful, the discharge management interface will prompt "Successful Connection".
4. When the converter is successfully connected or the discharge is stopped, and there is no abnormality in the discharge system, click the "Start Discharge" button on the control screen to start the external discharge.

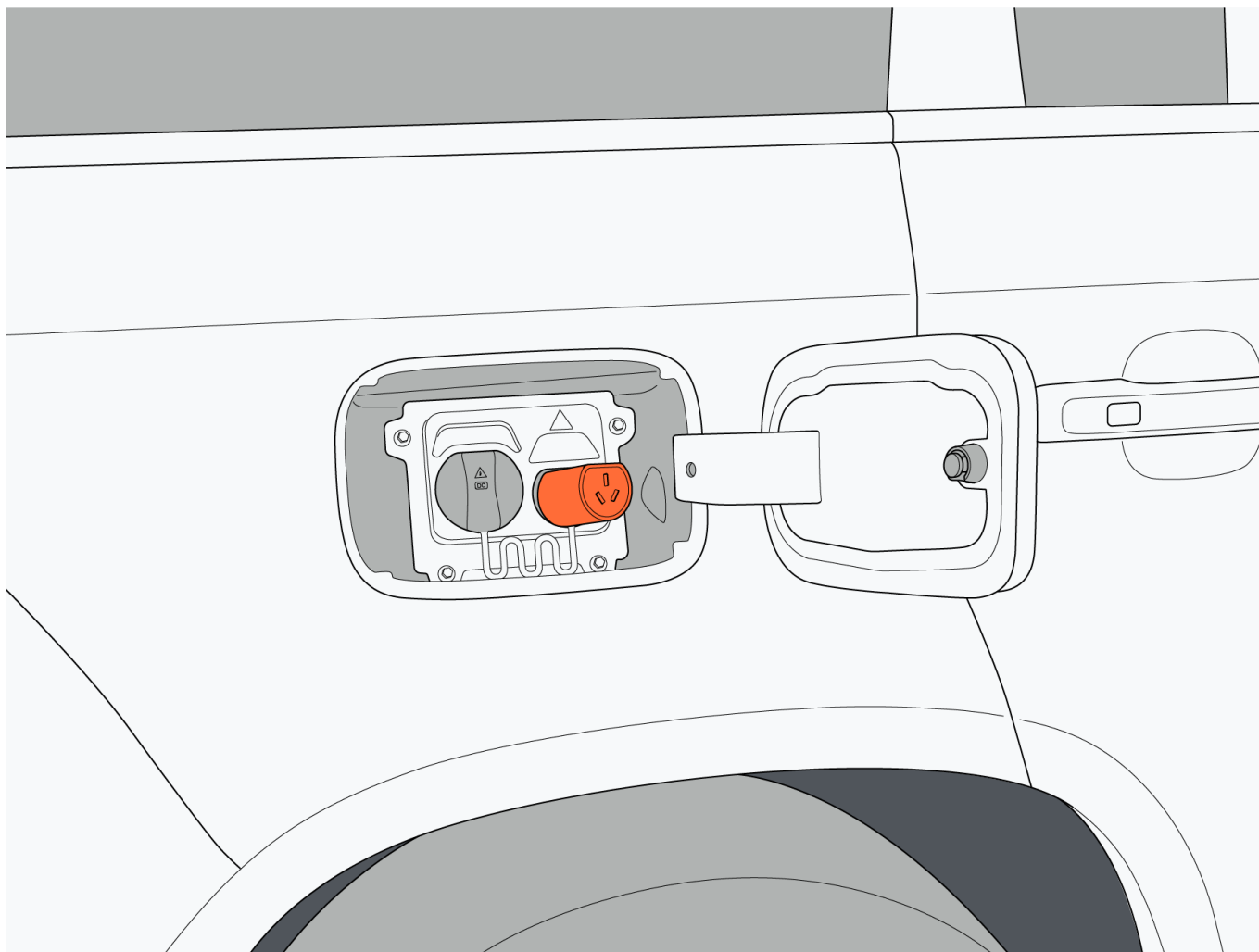

#### IV. Remove the converter

1. In the discharge management interface, click “Stop Discharge” or the power supply has ended.
2. Unplug the converter, install the charging port dust cover, and close the charging port cover.

#### Warning

- Do not discharge when the converter is damaged, rusted, damp, or has foreign objects, to avoid electric shock.
- Do not forcefully pull out the converter while discharging, as this may cause damage to the equipment or vehicle, or even electric shock.
- If there are any abnormalities during discharging, please stop the discharging.
- Do not discharge when the discharger head or the charging port is deformed, blackened or ablated.
- Do not discharge when there are obvious water stains in the charging port, to avoid damage to the vehicle or discharge equipment, or even electric shock.
- Do not touch the plug pins and adapter sockets of the load device.



## 7. Driving

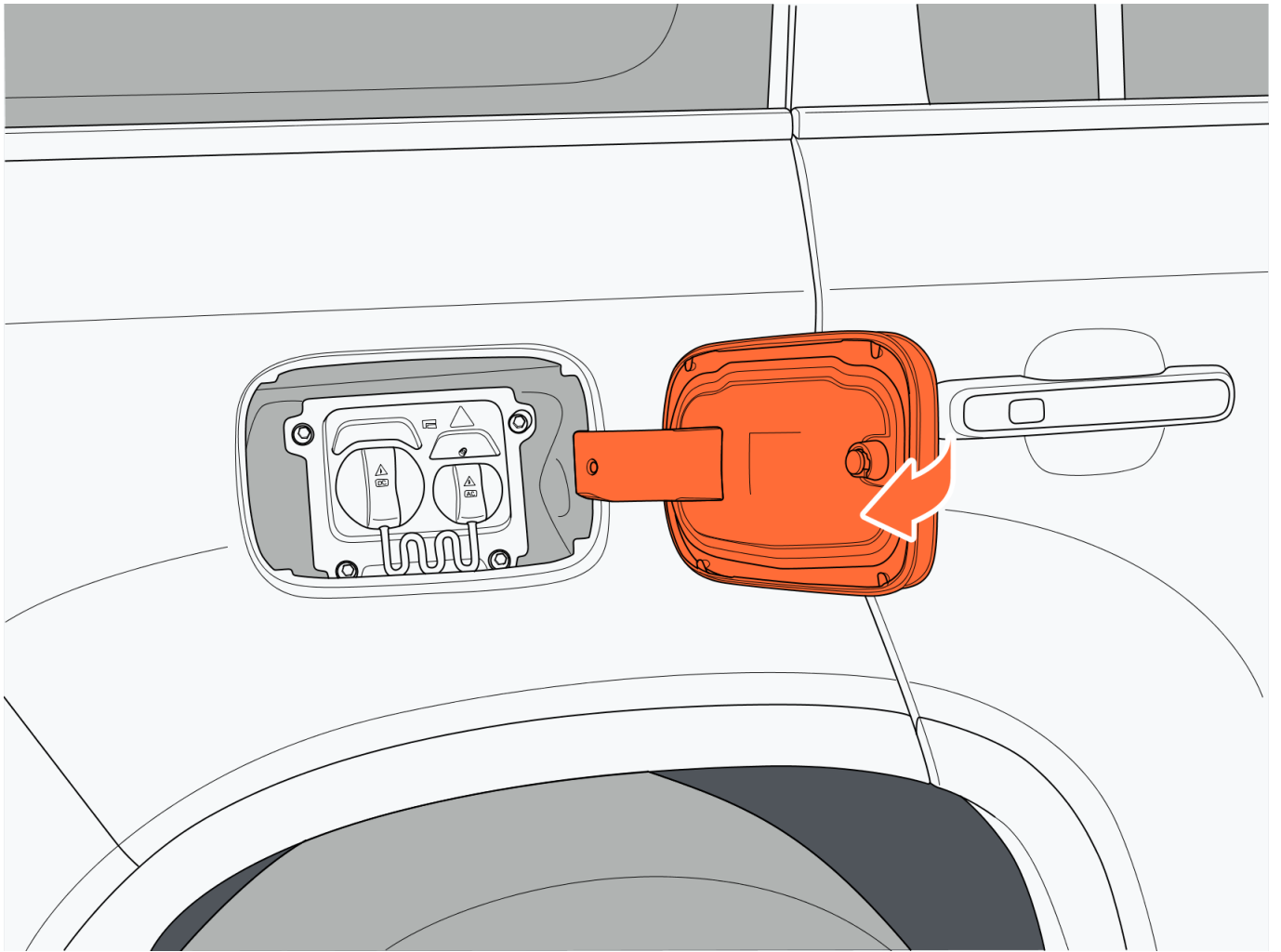

### 7.8.6 Power battery

#### I. Power battery

The power battery is the power source of the vehicle and can be charged and discharged repeatedly. The power battery is charged by an external power source, and the vehicle also can be charged through the motor during braking, coasting, or when the range extender is activated.

The power battery is located under the vehicle's floor, so be careful to prevent it from being knocked or bumped when driving over rough roads or uneven surfaces. The power battery is only suitable for this vehicle and must not be used on other vehicles or modified in any way. This will avoid electrical shocks, overheating, smoking, explosions, or leakage of electrolyte, etc.

#### II. Mileage

The mileage of the vehicle depends on the available electric energy, vehicle age (current battery life), weather conditions, temperature, road conditions, driving habits, etc.

- The mileage is related to the depth of discharge. To avoid excessive discharge that may affect the performance of the power battery, it is recommended to charge the vehicle in a timely manner after the low battery warning light on the central control screen is displayed.
- The use of A/C will reduce the mileage.
- In low-temperature conditions, the mileage will decrease during use due to the temperature characteristics of the battery, and the charging time will increase. Maintain a remaining mileage of no less than 80 km when using the vehicle.
- There will be some variation in the range at different speeds.

The following methods can be used to increase the mileage:

- Regularly maintain the vehicle.
- Keep tire pressure appropriate.
- Minimize the use of the vehicle in extreme weather conditions.
- Remove unnecessary items from the vehicle to reduce the load.
- At high speeds, close the windows to reduce air resistance, and conserve energy.
- Maintain a steady speed and try to avoid aggressive driving.

#### III. Power battery recycling

Information about the power battery will be recorded when the vehicle is registered and licensed. When it needs to replace or scrap the power battery, please contact the ROX Service Center for proper recycling and disposal. Scrapping of or discarding the power battery arbitrarily will pollute the environment or cause safety incidents. The owner will be responsible for the consequences.

#### Warning

- Improper dismantling, dismantling and storage of power batteries will cause personal injury and pollute the environment.
- Do not touch high-voltage system components to avoid electric shock.

## 7. Driving

---

- The vehicle's high-voltage harness is orange. Do not damage or pull on the high-voltage harness and plugs to avoid electric shock.
- Do not disassemble, disassemble or replace the power battery without authorization.
- Do not hand over discarded or old power batteries to unqualified recycling service outlets or individuals, or you will be responsible for the consequences.

### Eco-friendly

---

- The power battery contains toxic substances and corrosive substances. Arbitrary scrapping or discarding of the power battery will pollute the environment.

## 8.1 Maintenance and repair

### 8.1.1 New car run-in

#### I. Brake gear

After the vehicle runs about 500 km, the brake disc and brake pad can achieve better braking performance. Therefore, during this running-in period, please drive with caution.

#### II. Tire

The adhesion performance of new tires is not at its best. For the first 300 km, i.e., the running-in period, drive at appropriate speeds and with caution. This can extend the tire's lifespan and enhance safety.

#### III. After replacing parts

During the driving time after the running-in period, if the tires, braking devices, etc. are replaced with new parts, they must be run-in again according to the relevant regulations.

### 8.1.2 Vehicle cleaning

#### I. Vehicle cleaning

To protect the vehicle and maintain it in the best condition, perform the following manual cleaning operations:

1. Rinse the vehicle from top to bottom with a large amount of clean water to remove dust.
2. Wash the body of the vehicle with a sponge or soft cloth.
3. For hard-to-remove substances, first soften them with detergent and then rinse with clean water.
4. After washing, carefully dry the vehicle's paint surface with a soft towel.
5. Do not directly wash the front bumper grille with a high-pressure water gun, as non-professional washing can cause the radiator fins to collapse.

#### II. Automatic car wash

1. Before washing, fold the exterior rearview mirrors and close the windows completely.
2. Before washing, inform the staff that there is a LIDAR on the roof to assess whether it needs to avoid the LIDAR during washing.
3. It is best to use fabric washing device when washing the vehicle to avoid damaging the paint.
4. Wash the vehicle from top to bottom from the front.
5. After washing, carefully dry the vehicle's paint surface with a soft towel.
6. Before driving, make sure the exterior mirrors are unfolded.
7. After washing the vehicle, gently press the brake pedal several times in succession to remove any residual water from the brake discs. This can avoid affecting braking effectiveness and prevent rusting of the brake discs.

#### III. Cleaning the wheel hub

1. When removing stubborn stains, do not use hard brushes or abrasive cleaners.
2. Do not use detergent on hot wheel hubs.

# 8 Maintenance and repair

3. After the wheel hubs cool down, you can use special wheel hub detergent. Rinse them off immediately after applying.

## IV. Car lights

1. When cleaning car lights, do not dry wipe or use abrasive or corrosive detergents.
2. For stubborn dirt, first soften it with detergent and then wash it away with water.
3. Remove ice with deicing spray. Do not use a deicing shovel.

### Warning

- Keep the charging port cover and tank cap closed during vehicle cleaning to avoid damage.
- Do not wax the surface of the car lights. Avoid damaging the car lights.
- High-pressure car washing with excessive water pressure may damage the paint.
- Do not rinse the vehicle's dust cover with a high-pressure water gun for a long time.
- Do not wash the high-voltage components at the bottom of the vehicle to avoid electrical shock or vehicle damage.

## 8.1.3 Vehicle maintenance

### I. Vehicle paint

Regular daily maintenance helps ensure driving safety and vehicle value retention. Environmental factors such as air pollution or natural impurities (resin or pollen, etc.) in certain areas may affect vehicle paint. Adjust the frequency and scope of vehicle maintenance accordingly.

Remove corrosive substances such as spilled fuel, engine oil, lubricant, or bird droppings immediately to prevent paint discoloration or fading.

### II. Leather curing

Regularly remove dust and impurities from the leather surface with a towel or vacuum cleaner.

When the leather is contaminated, clean it in time. First wipe the dirt with tissue or towel, and then clean it with a little water on the towel. For stubborn stains, clean them with leather detergent. Finally dry the water stains on the surface.

Apply neutral care agent to the leather once a month for professional maintenance to maintain its quality.

### Caution

- Do not place sharp objects such as keys or scissors on the seats to avoid scratching or tearing the leather.
- Do not use alcohol, corrosive, acidic, or alkaline care agents, as they will damage the leather's protective layer.
- Do not turn on the seat heater to dry the seats. Do not treat the seat with an iron on the seats.
- Avoid soaking the seats with liquid.

### III. Seat belt

Dirty seat belts may hinder retraction and affect safety performance. Seat belts should only be cleaned with mild soapy water. They can only be retracted when completely dry.

## Caution

- Do not use bleach, dyes or cleaning solvents, as these can reduce the durability of the seat belts.
- Always wait for the seat belt to completely dry before retracting it. Avoid damaging the seat belt retractor.

### IV. Wheel

To maintain the beautiful appearance of the wheel hubs over the long term, the wheels require regular maintenance. It is recommended to thoroughly clean the wheels every two weeks to prevent fine abrasive particles, dirt or salt from solidifying on them after braking, which could otherwise corrode the wheels.

### V. Underbody protection

The vehicle's underbody is treated to withstand chemical and mechanical damage. However, damage to the protective layer is inevitable during driving. It is advisable to check the vehicle's underbody and chassis protection layer at regular intervals, preferably before winter and in spring, and make necessary repairs if required.

## 8.1.4 Anti-corrosion

### I. Common factors affecting vehicle corrosion

- Accumulated dirt, sand or ice under the body of the vehicle may accelerate corrosion.
- Industrial pollution, salt in the air in coastal areas and excessive road salt may accelerate the corrosion process of the paint.
- Increased temperature may accelerate the corrosion of poorly ventilated parts.
- Driving in high relative humidity or hot and humid environments may accelerate corrosion.
- Damage to the coating or other protective layers caused by sandstone impact or minor accidents may accelerate corrosion.

### II. Anti-corrosion measures

- Wash the car regularly to keep it clean.
- Regularly check the paint for damage and repair it promptly.
- If you frequently drive on roads with snow-melting salt, salt-alkali soils or coastal areas with salt-containing roads, you should at least clean off any attachments from the bottom of the car every month.
- If the vehicle accumulates insects, asphalt, cement or other similar substances, clean them off promptly.

## 8 Maintenance and repair

### 8.2 Regular maintenance

#### 8.2.1 Regular maintenance

Maintenance Item	Maintenance cycle (subject to time or mileage, whichever comes first))	
	Time	Mileage
Minor maintenance for range extender system (oil, engine filter)	1 years	Range extender has worked for 10,000 km
Major maintenance for range extender system (oil, filter, air filter element)	2 years	Range extender has worked for 20,000 km
Air conditioning filter	1 year	20,000 km
Spark plug	--	Range extender has worked for 40,000 km
Brake fluid	4 years	80,000 km
Coolant	6 years	120,000 km

### 8.3 Self-maintenance

#### 8.3.1 Hood

I. Open the hood

1. Pull the engine hood unlock handle twice in succession to unlock the engine hood.

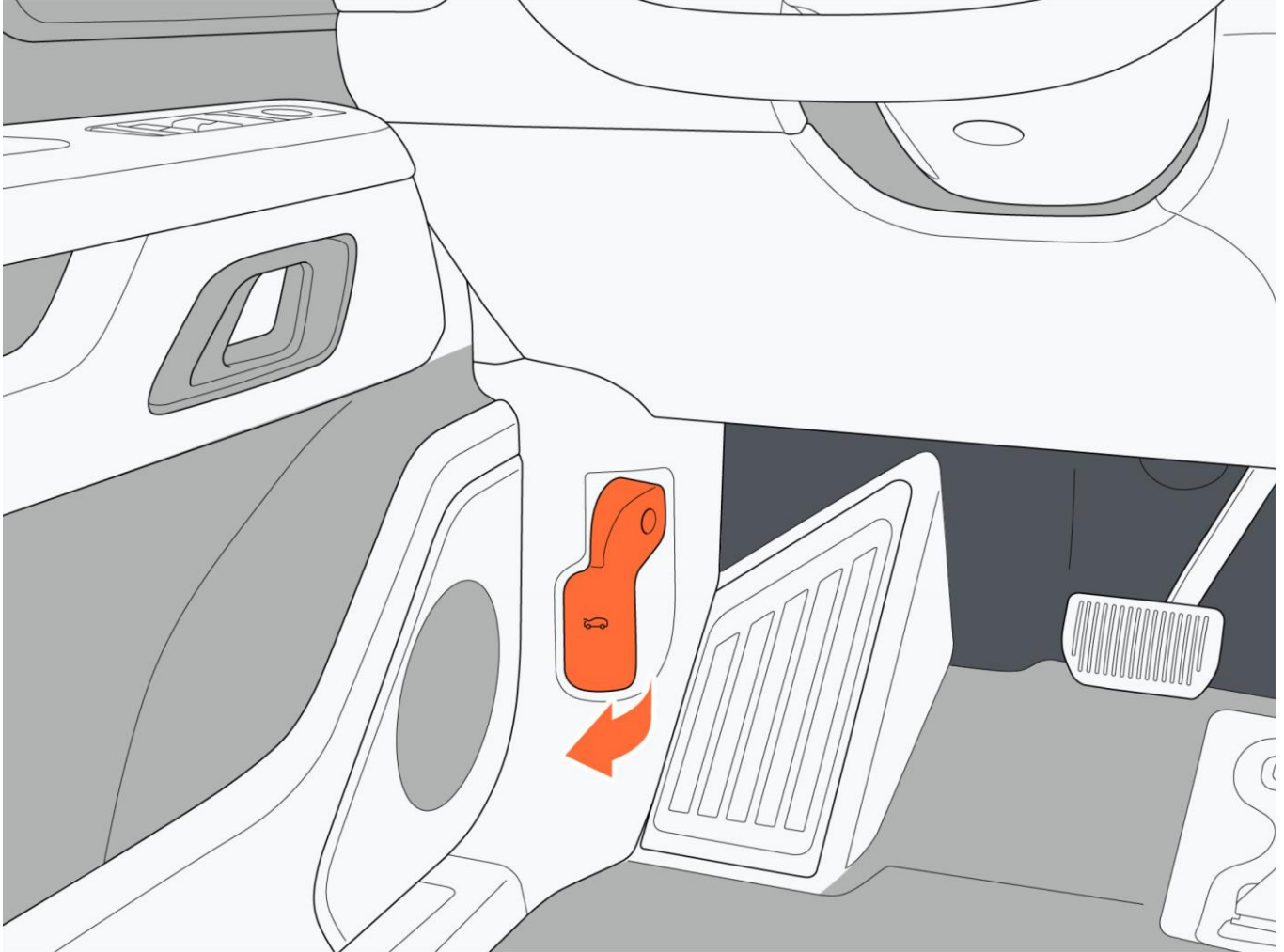



## 8 Maintenance and repair

2. After unlocking the engine hood, lift it up.

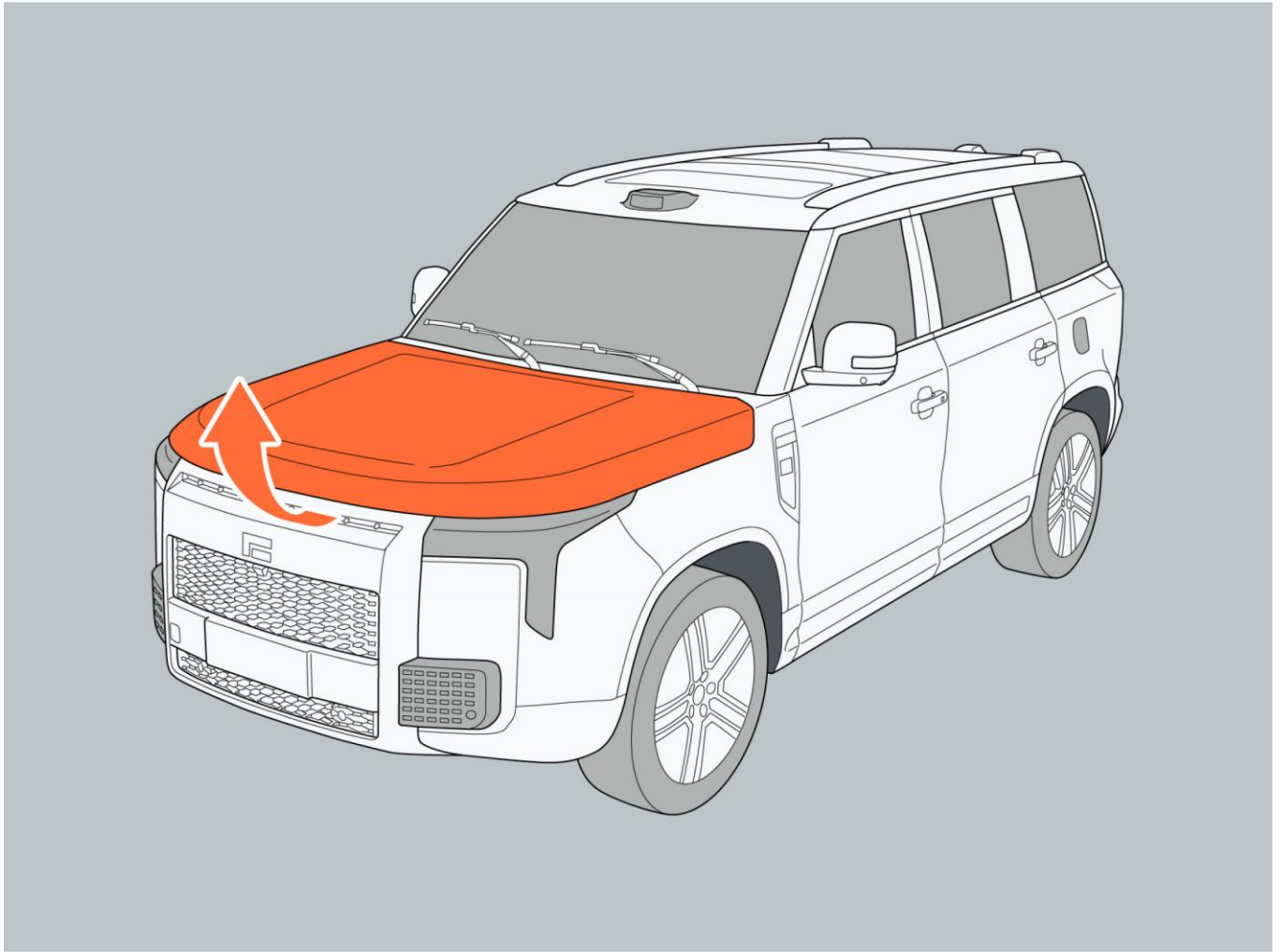

### II. Close the hood

Lower the engine hood to allow it to close under its own weight. If the hood is not fully locked, press down firmly on the front end of the hood. After closing the engine hood, try to lift it slightly to ensure that it is fully locked.

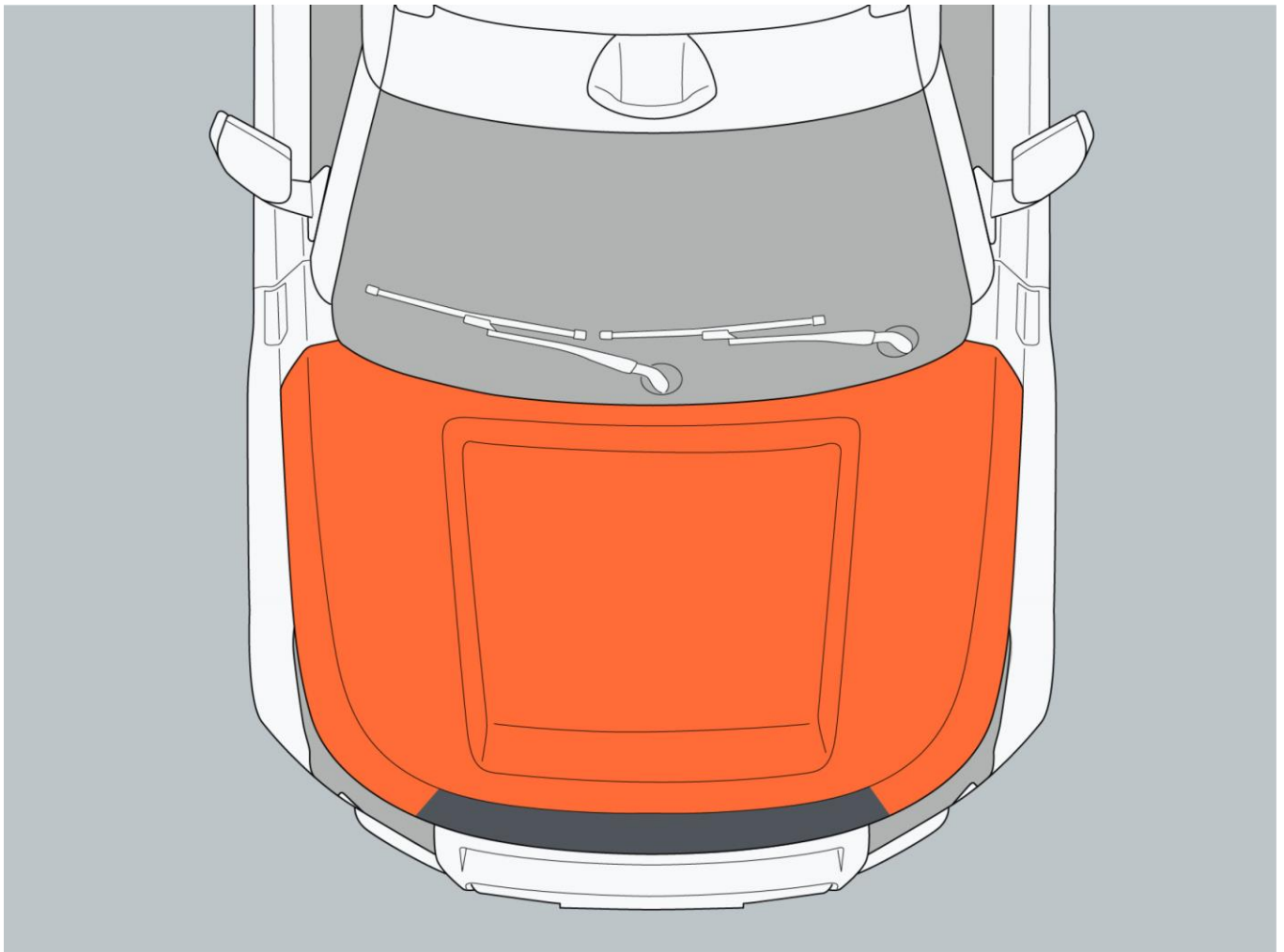

### 8.3.2 Engine compartment

#### I. Location of oil/fluid filling port

S/N	Name
1	Cleaning solution filter port
2	Power battery coolant filling port
3	Engine oil filling port
4	Brake fluid filling port
5	Range extender coolant filling port

## 8 Maintenance and repair

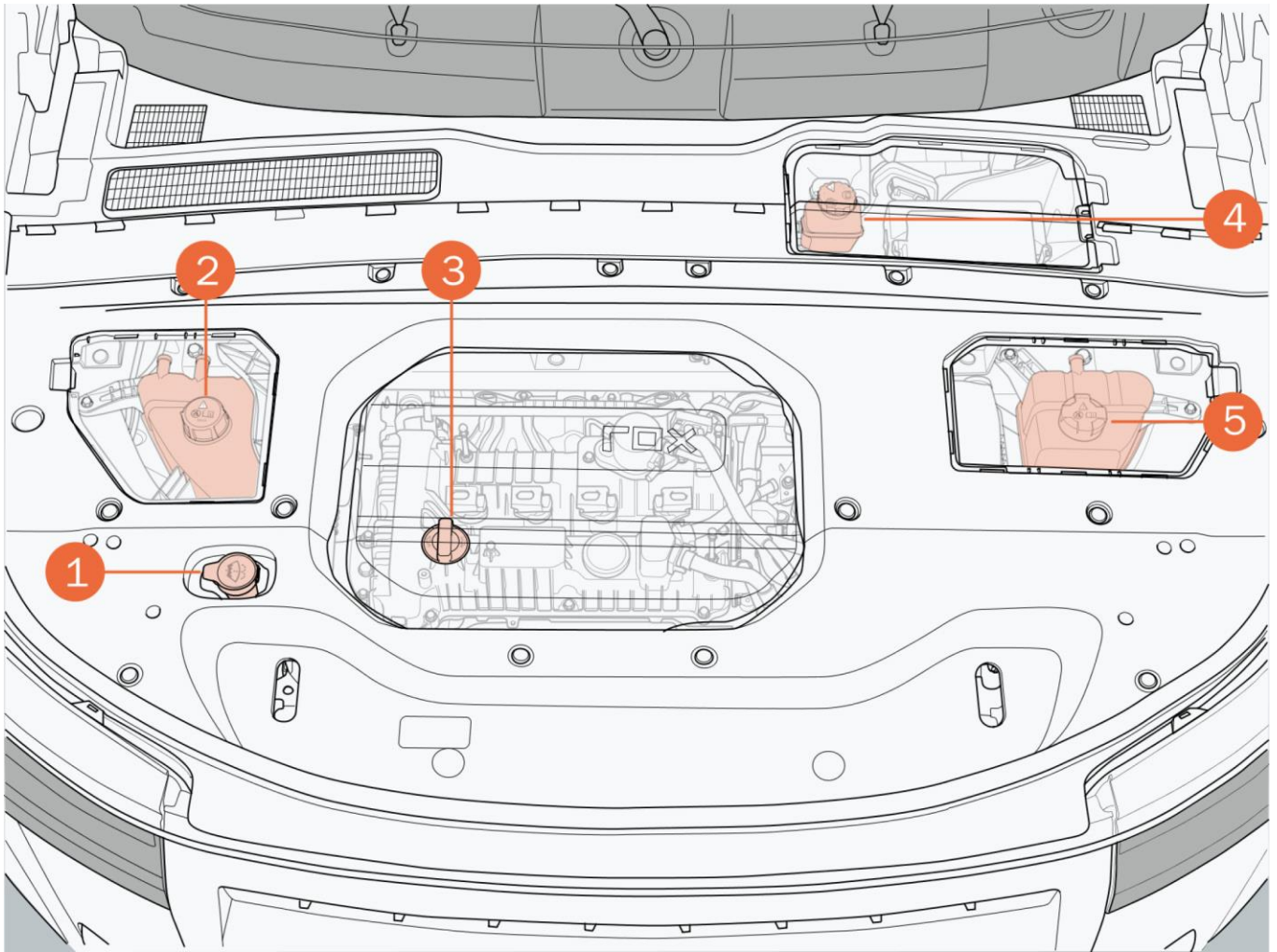

### Warning

- Do not open the range extender, drive motor and power battery integrated expansion water tank cap immediately after driving the vehicle to avoid burns.
- Do not place flammable materials such as paper or rags inside the engine compartment.
- Do not get close to parts that may move, such as fans and belts, to avoid personal injury or vehicle damage due to hands, clothing, or tools being entrapped suddenly.
- Do not allow the level of oil to be outside the normal filling mileage.
- Do not touch parts inside the engine compartment immediately after driving the vehicle to avoid burns.

### 8.3.3 Battery

#### I. Warning sign information



#### II. Battery position

The battery is located on the left side of the trunk. You can find it by taking out the luggage pad and removing the tool box.

#### III. When the battery fails

If the battery fault light appears on the instrument panel, it indicates that the battery is low charge or there is a fault in the battery system. Please contact the ROX Service Center promptly.

#### Caution

- If a battery failure leads to the battery running out of charge and the vehicle cannot be started normally, please contact the ROX Service Center.
- This vehicle uses lithium-ion battery. Do not connect an external power source to charge the battery, as this may damage the battery.
- Jump starting between this vehicle and another vehicle is prohibited to avoid damaging the battery.
- If it needs to replace a battery, contact the ROX Service Center. Do not attempt to replace the 12 V battery by yourself.

# 8 Maintenance and repair

## 8.3.4 LIDAR

To ensure the normal operation of the LIDAR, please regularly clean the LIDAR transceiver window.

Regular cleaning is the best way to protect the LIDAR transceiver window from harmful environmental effects. The cleaning interval depends on many factors (such as: usage frequency, vehicle storage in a parking lot, under a tree, season, climatic conditions, environmental impact, etc.). The longer insect residue, bird droppings, resin, road dust, industrial dust, asphalt, soot particles, deicing salt or other erosive deposits adhere to the transceiver window, the greater their damage. High temperatures (such as intense sunlight) can also exacerbate the erosive effects. After finding any of the above-mentioned corrosive substances on the LIDAR transceiver window, it should be cleaned immediately. Therefore, it may require cleaning once a week, but in some cases, it can also be cleaned once a month.

### Warning

- When cleaning the LIDAR, ensure that the vehicle power is in the “OFF” mode to avoid eye damage from the LIDAR.

### Caution

- Do not clean it with detergent containing alcohol or solvents (such as nitro diluents, cooling cleaners, fuel, etc.), as there is a risk of cracking the transceiver window.
- Do not rub the LIDAR transceiver window when it is dry. Never use a cleaning agent with a polishing effect, as there is a risk of scratching or cracking.

## 8.3.5 Tire

### I. Use of tire

To ensure driving safety and comfort, we remind you to read carefully and strictly follow the following precautions when driving your vehicle for the safety of yourself and your family:

- Choose to drive on roads with good conditions.
- During driving, stay focused and avoid obstacles such as bumps or depressions in front of you. If unavoidable, reduce your speed and drive slowly through them.
- Regularly check the tires for damage (such as cuts or cracks) and irregularly check abnormal wear.
- Maintain the correct tire pressure.



### II. Tread depth

Wear marks are located on the tire's circumference, with the legal minimum depth being 1.6 mm.

#### **i** Tip

When the tires wear down to the wear mark, replace them promptly to avoid insufficient grip.

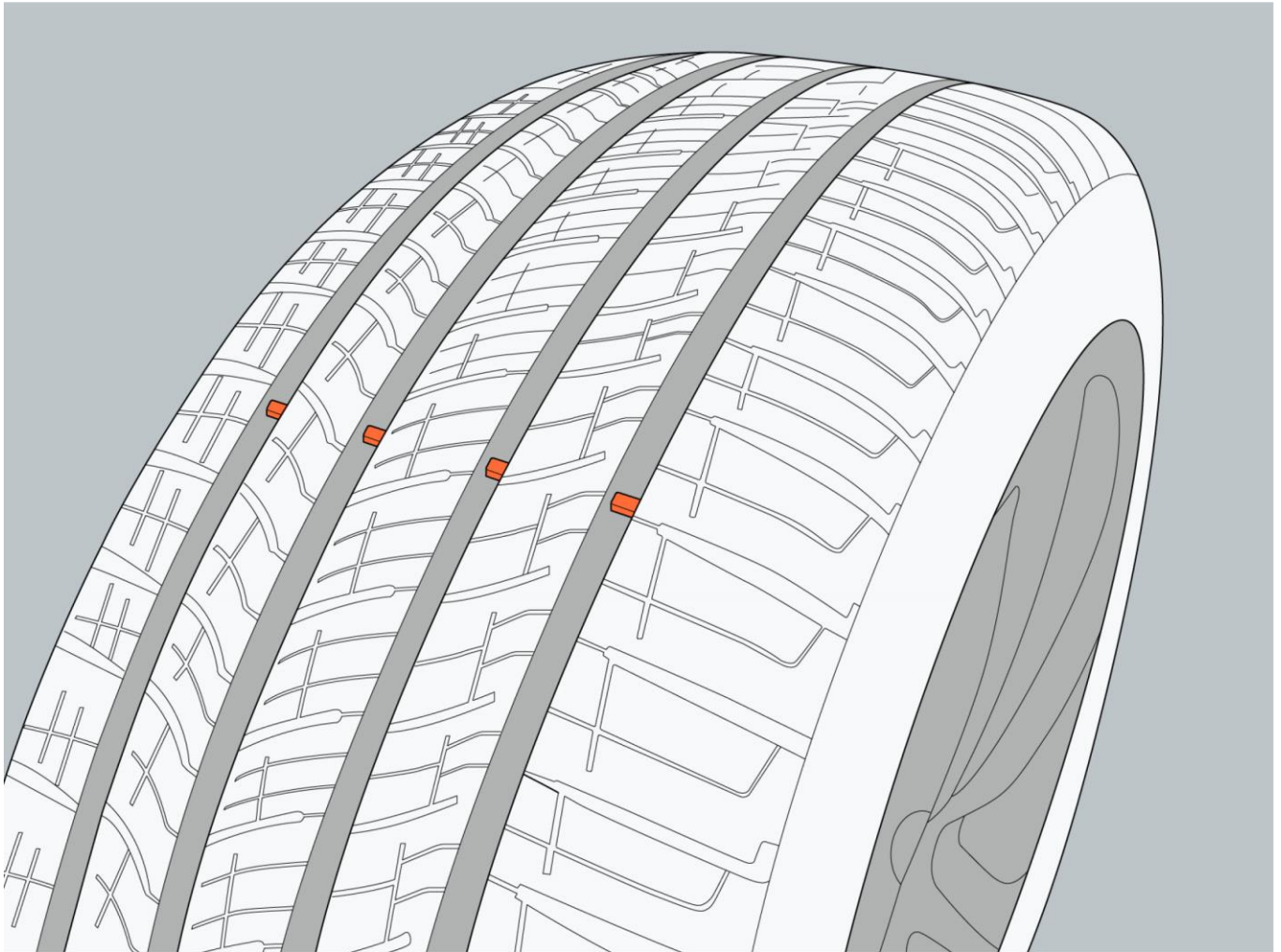

### III. Tire inspection

For your driving safety, please regularly check the tires for the following, and contact the ROX Service Center for a re-inspection and replacement if any damage or irregularities are found or suspected.

- Check if the tire tread is unevenly worn. Remove any foreign objects from the tread (such as stones, glass, etc.).
- Check if the tread has worn down to the point where the wear mark is exposed.
- Prevent the tires from contacting engine oil, grease or fuel.
- If the dust cover on the tire valve is missing, replace it as soon as possible.

#### **!** Warning

- Do not use retreaded tires or tires with unknown age.

## 8 Maintenance and repair

- The four tires should be of the same model, tread pattern and manufacturer.
- After tire replacement, the tires must be checked for dynamic balance.
- When replacing tires, they must be replaced in pairs. Replacing only one tire will severely affect the vehicle's handling.
- Driving over obstacles quickly, such as hitting curbs or road damage, may cause tire damage. Larger wheels have a smaller tire cross-section. When the tire cross-section is small, the risk of tire damage will increase, and there is a danger of accidents and damage to objects. Try to avoid obstacles or drive slowly and carefully.

### IV. Tire storage

After replacing tires, store the unused tires properly:

1. Please make sure to store the tires in a cool, dry place.
2. Tires without rims should be stored upright.
3. Prevent the tires from coming being contaminated with engine oil, grease, fuel and solvents.

### V. Four-wheel rotation

To ensure even tire wear and extend the tire's service life, it is recommended to rotate the tires every approximately 10,000 km.

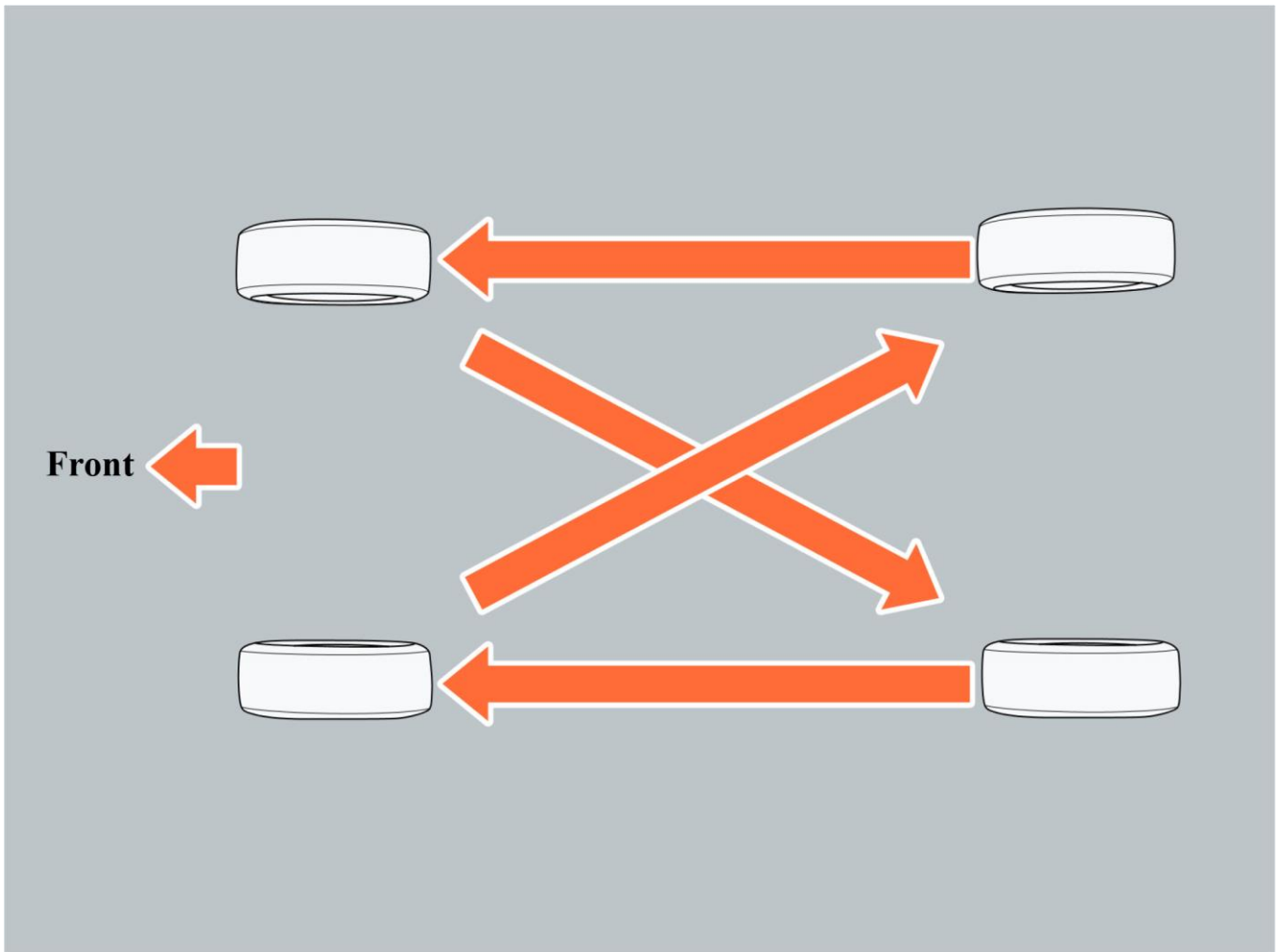

### 8.3.6 Tire pressure

#### I. Tire pressure label

The tire pressure label is located on the rim of the driver's door, and the tire pressure shown on the label is the cold tire pressure value.

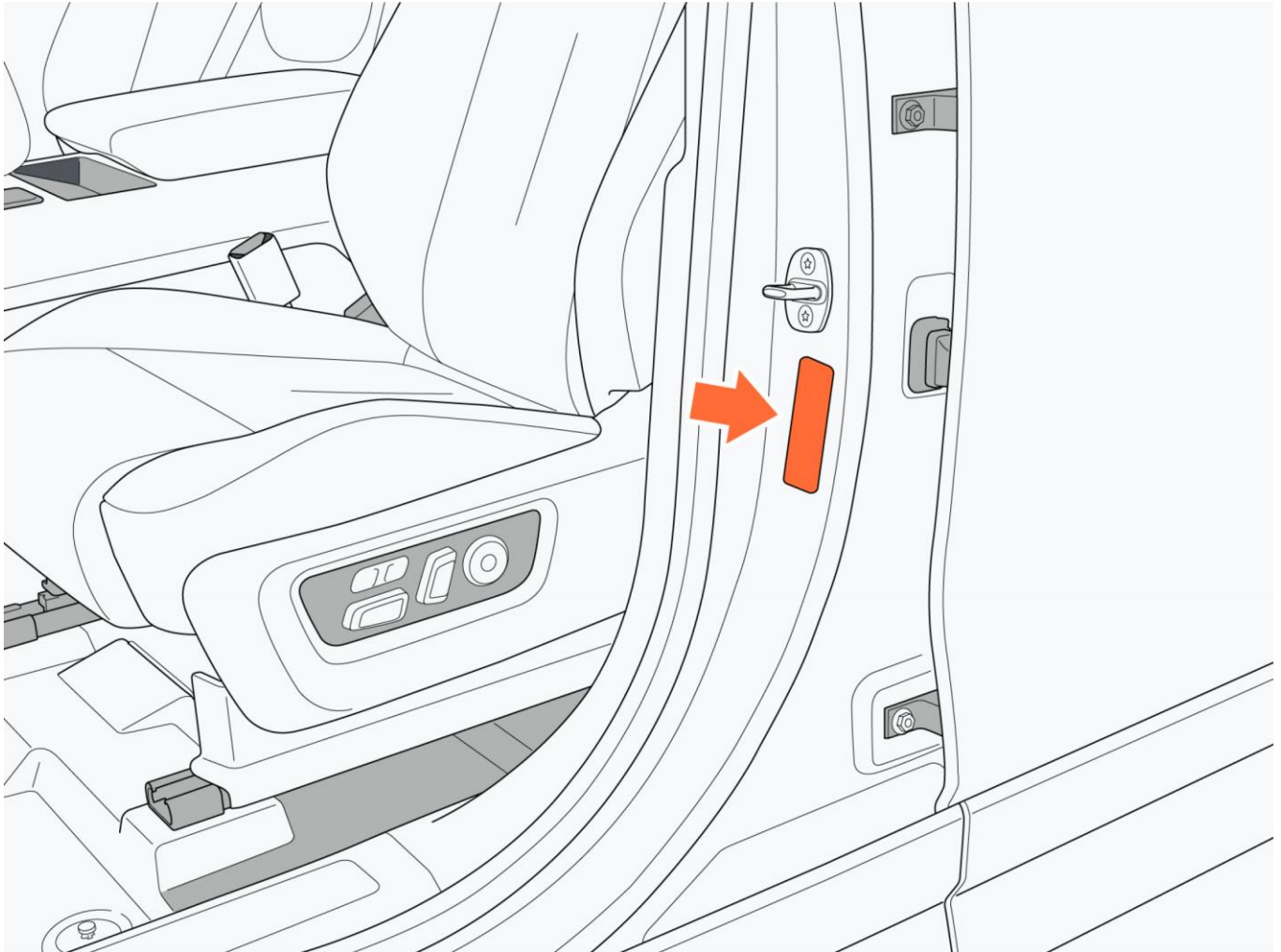

#### II. Tire pressure check

When checking tire pressure, observe the following:

- It is recommended to check tire pressure at least once a month.
- When checking tire pressure, the vehicle should be parked for at least 3 h or have not driven more than 2 km, as this will allow for a more accurate measurement of the tire's cold tire pressure.
- Tire pressure will be higher than the cold tire pressure when driving, which is a normal phenomenon. Do not check tire pressure after long periods of driving.

#### III. Abnormal conditions

When tire pressure is abnormal, the following conditions may occur:

- Reduction in driving comfort and maneuverability.
- Uneven tire wear.
- Decreased safety.



# 8 Maintenance and repair

## Caution

- When a tire deflates, park the vehicle in a safe area and contact the ROX Service Center promptly.

### 8.3.7 Wheel

When the tires are deformed, cracked, or severely corroded, they should be replaced promptly, as this may affect the vehicle's comfort or lead to loss of control due to wheel failure.

#### I. Tire selection

When replacing tires, it is important to ensure that the tires to be replaced have the same load capacity and size as the original tires. The ROX Service Center does not recommend using:

- Tires of different specifications or types.
- Tires with an unclear age or date of manufacture.
- Corrected tires.
- Retreaded tires.

#### II. Tire replacement

1. Always use the wheel bolts specified by ROX or equivalent products designed specifically for aluminum rims.
2. When performing a dynamic balance, please use the balance weights specified by ROX or equivalent products.

## Caution

- The repair or replacement of tires may affect the normal operation of the tire pressure monitoring system. Therefore, when you need to repair or replace your tires, please contact the ROX Service Center.
- Make sure to use parts specified by ROX or equivalent in specification.

### 8.3.8 Air conditioning filter

Check and replace A/C filters regularly according to maintenance plan. If the vehicle is driven in dusty areas or busy traffic areas, it is advisable to shorten the replacement interval for the A/C filter.

If the air flow from the vehicle's air vents is weak or there is an unpleasant odor when A/C is turned on, it may indicate that the A/C filter is clogged or has foreign objects. Check the A/C filter and replace it if necessary.

### 8.3.9 Windshield wiper

#### Wiper check

1. Contaminants on the windshield or wiper blades can reduce the utility of the wiper blades. Contaminants include ice, car wash spray wax, cleaning solutions containing bacteria and/or waterproofing agents, bird droppings, tree sap and other organic substances.

2. Check if the wiper blades are worn or broken.
3. Check if there is any unusual noise when the wiper blades are in operation.

### Wiper maintenance

1. If the wiper blades are not working properly or show signs of wear, clean the windshield and wiper blades with mild detergent, then rinse with clean water and replace them as needed.
2. Only use cleaning products that are certified for use on automotive glass and rubber. Improper use may cause damage or contamination, leading to glare on the windshield.

### Caution

- Do not use the wipers when the windshield is dry or when the wash pot is empty.
- Before turning on the windshield wipers, thoroughly defrost and clear the snow from the windshield.
- Before washing the car, ensure that the windshield wipers are in the off position.
- Allowing the wiper arm to contact the windshield without a wiper blade installed may damage the windshield. Any damage resulting therefrom is not covered by the vehicle warranty. Do not allow the wiper arm contact the windshield.

### Wiper replacement

1. After lifting the wiper arm, place a thicker towel under the lower part of the wiper arm against the windshield to prevent the wiper arm from accidentally bouncing back and damaging the windshield.
2. After lifting the wiper arm, press the lock locking clips on the left and right sides of the wiper, then pull the wiper forward.
3. After replacing the wiper, gently place the wiper arm back on the windshield.

### Tip

The replacement method for the wiper on the left and right sides is the same with the rear window wiper.

## 8 Maintenance and repair

### 8.3.10 Remote-control key battery

When the battery power is too low or exhausted, replace the battery with a new one. Otherwise, some functions of the remote key will be restricted (e.g., starting the system, remote control functions cannot be used normally, etc.).

#### I. Replace the battery

1. Pinch the trim cover on both sides and pull it outwards in the direction of the arrow.

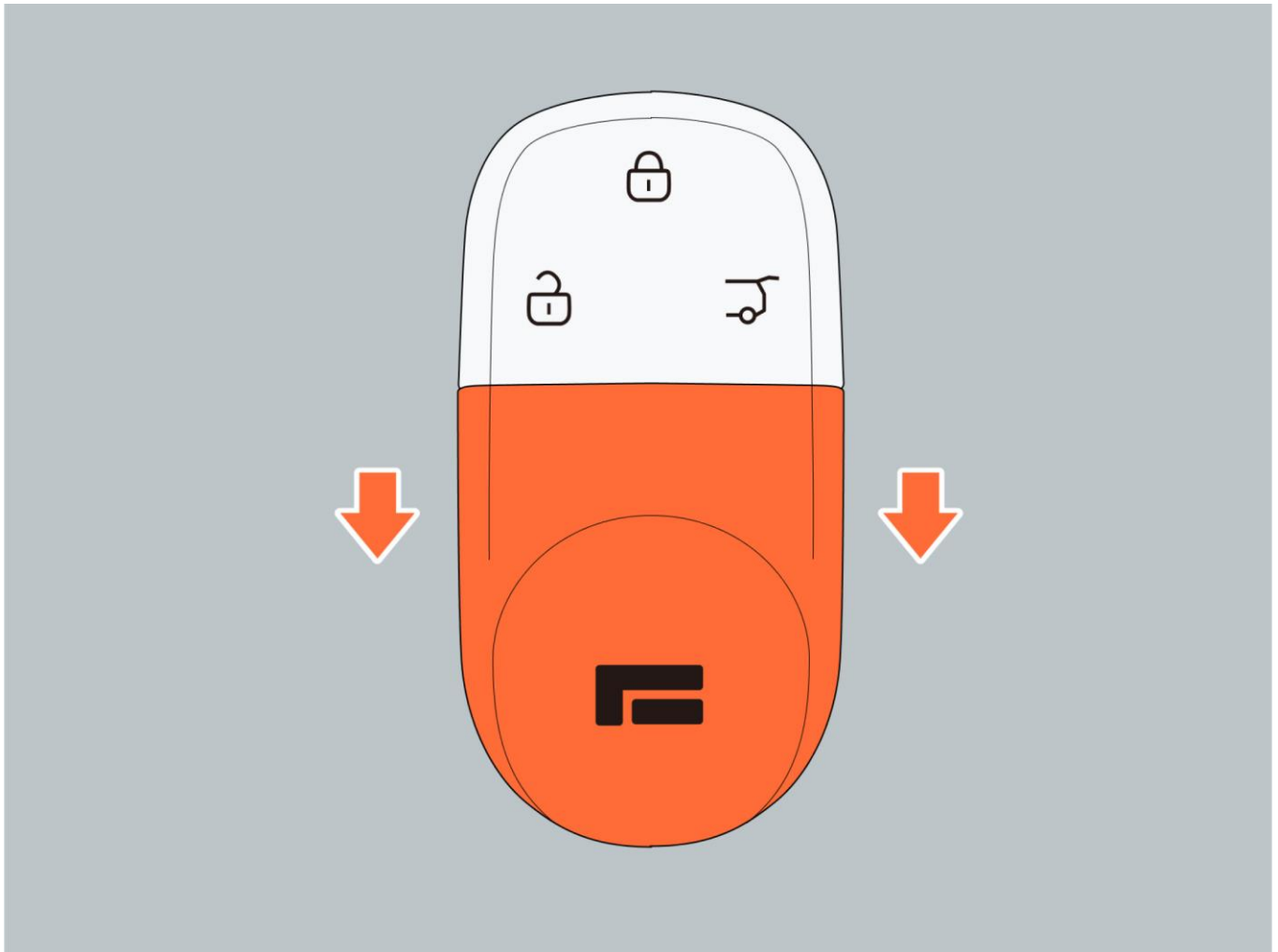

## 8 Maintenance and repair

2. After removing the trim cover, gently pry the gaps on both sides of the bracket with a small flathead screwdriver or a similar tool and separate the panel component.



## 8 Maintenance and repair

3. After separating the panel component, remove the button battery, and install it with the positive terminal facing down.

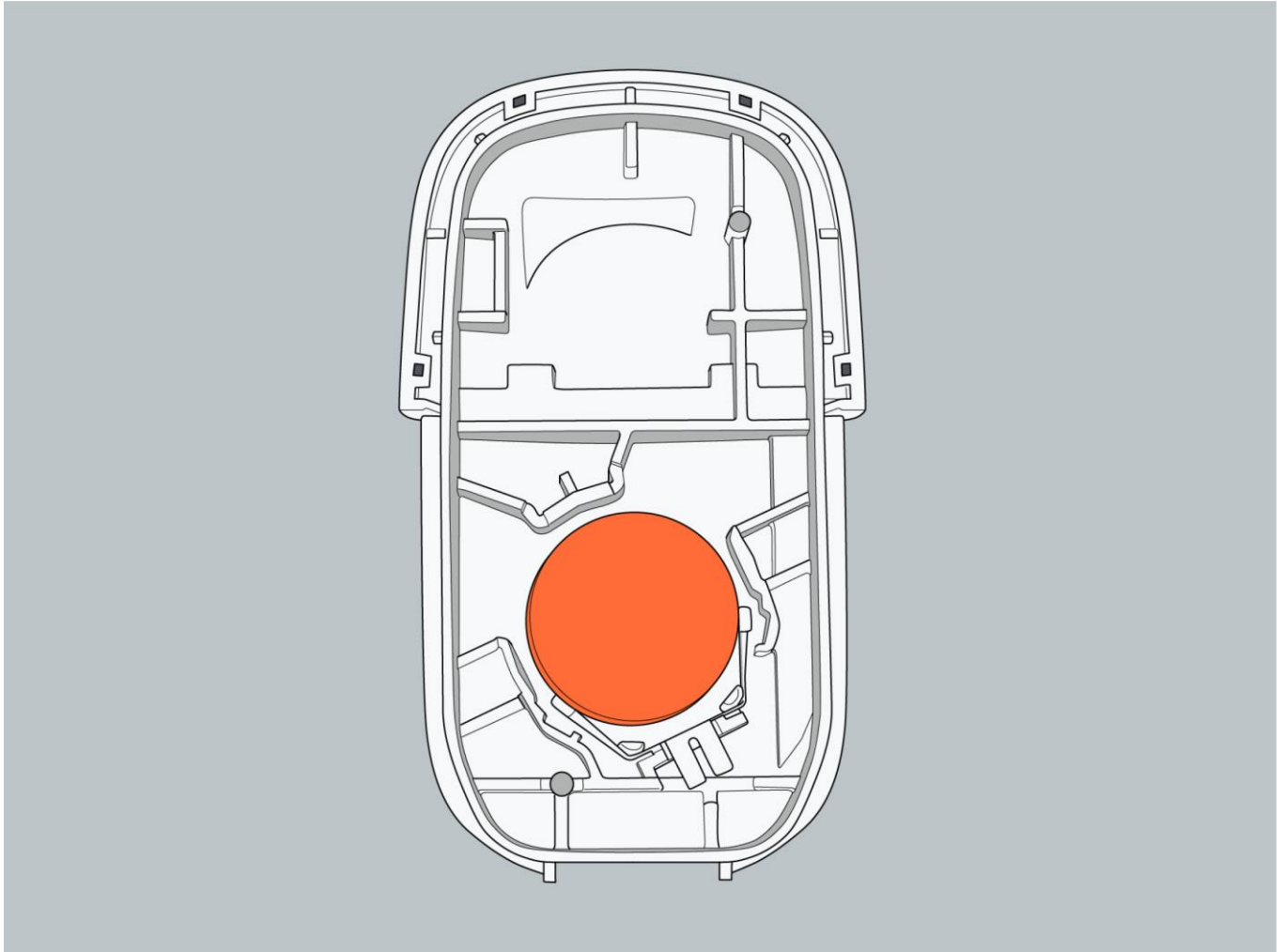

4. After the battery is installed, assemble it in reverse order of the disassembly steps.

### Warning

- Place the battery in a location where children cannot reach to prevent accidental swallowing it.
- When installing the battery, avoid sweat or water on your hands to prevent the battery from rusting and damaging the remote key.

### Tip

- When the battery needs to be replaced, it is recommended to have a professional from the ROX Service Center replace it.
- Button Battery (model: CR2032).

### Eco-friendly

- The battery contains toxic substances and corrosive materials. Please dispose of the exhausted battery at a qualified professional service center or recycling outlet for used batteries.

### 8.3.11 Check and replace the fuse

Fuses protect automotive electrical equipment by preventing overload in the circuit. A fuse that has blown indicates that the circuit it was protecting has a fault and is no longer working.

If a fuse is damaged, please contact the ROX Service Center to replace the damaged fuse promptly.

### Warning

- Do not use conductor or other conductive items as substitutes for fuses, as they may not melt in time, leading to circuit damage or even a fire.
- Do not modify the fuse or fuse box.

## 8.4 Vehicle long-term parking

### 8.4.1 Vehicle long-term parking

#### I. Parking place

When the vehicle needs to be parked for a long period, try to park on a flat road. It is recommended to park in a dry, well-ventilated environment away from sources of heat and corrosive substances, and to use a car cover. This helps slow down the aging of rubber parts and paintwork.

#### II. Ambient temperature

To maintain the vehicle's good performance, avoid exposing the vehicle to an environment above 55°C or below -30°C for more than 24 h.

#### III. Battery

## 8 Maintenance and repair

When the vehicle detects that the battery voltage is too low, the intelligent charging function is triggered, and the battery will be charged through the power battery. Therefore, when the vehicle is restarted after being parked for a long time, the remaining mileage displayed on the central control screen will decrease, which is a normal phenomenon.

### IV. Power battery

- Before the vehicle is parked for a long time, confirm that the power battery's charge is within a relatively sufficient mileage (50% ~ 70%).
- The vehicle must be maintained at least once every three months. It is recommended to charge the battery to 50%~70% before parking. If it exceeds three months, the power battery charge needs to be charged up to 70%, and then the vehicle can be parked.
- Before using the vehicle again after it has been parked for more than three months, please check the instrument panel for any battery alarms. If any, please contact the ROX Service Center.

### Tip

- For vehicles that are not used for a long time, regular maintenance is essential to prevent irreversible battery damage.
- We recommend that you check the battery charge every week and drive the vehicle once a month. If the battery charge is insufficient, please arrange for a charge before parking it.
- If the vehicle is continuously parked and not used for more than 3 months without regular maintenance of the power battery by following the manual's instructions, it will not be covered by the warranty.
- If OTA is frequently used to remotely control the vehicle during long-term parking, it will increase the power consumption of the vehicle and accelerate power loss. Users should shorten the vehicle maintenance cycle and avoid long-term parking under low battery conditions.
- When the power battery's charge is too low, the system will remind the user to charge the power battery through the APP.
- In the event of the vehicle being submerged in water due to weather or special reasons, do not turn on the vehicle's power, as this may cause safety risks or secondary damage to the vehicle.
- Avoid vehicles wading over long distances or for long periods of time.

## 9.1 Measures to be taken in case of emergency

### 9.1.1 On-board tools

#### ⚠ Caution

- The driver must be familiar with the location and usage method of the on-board tools to cope with emergency situations.
- After using the on-board tools, make sure to put them back in the designated place and secure them firmly. Placing them randomly may easily cause accidents.
- The jack (if any) provided with the vehicle is a dedicated tool for the vehicle. It is prohibited to use the jack of this vehicle on other vehicles, and vice versa.

The on-board tools are located in the trunk toolbox:

S/N	Name	S/N	Name
1	Towing hook	2	Wheel wrench
3	Warning sign	4	Anti-theft bolt adapter
5	Jack rocker	6	Jack
7	Inflation pump		

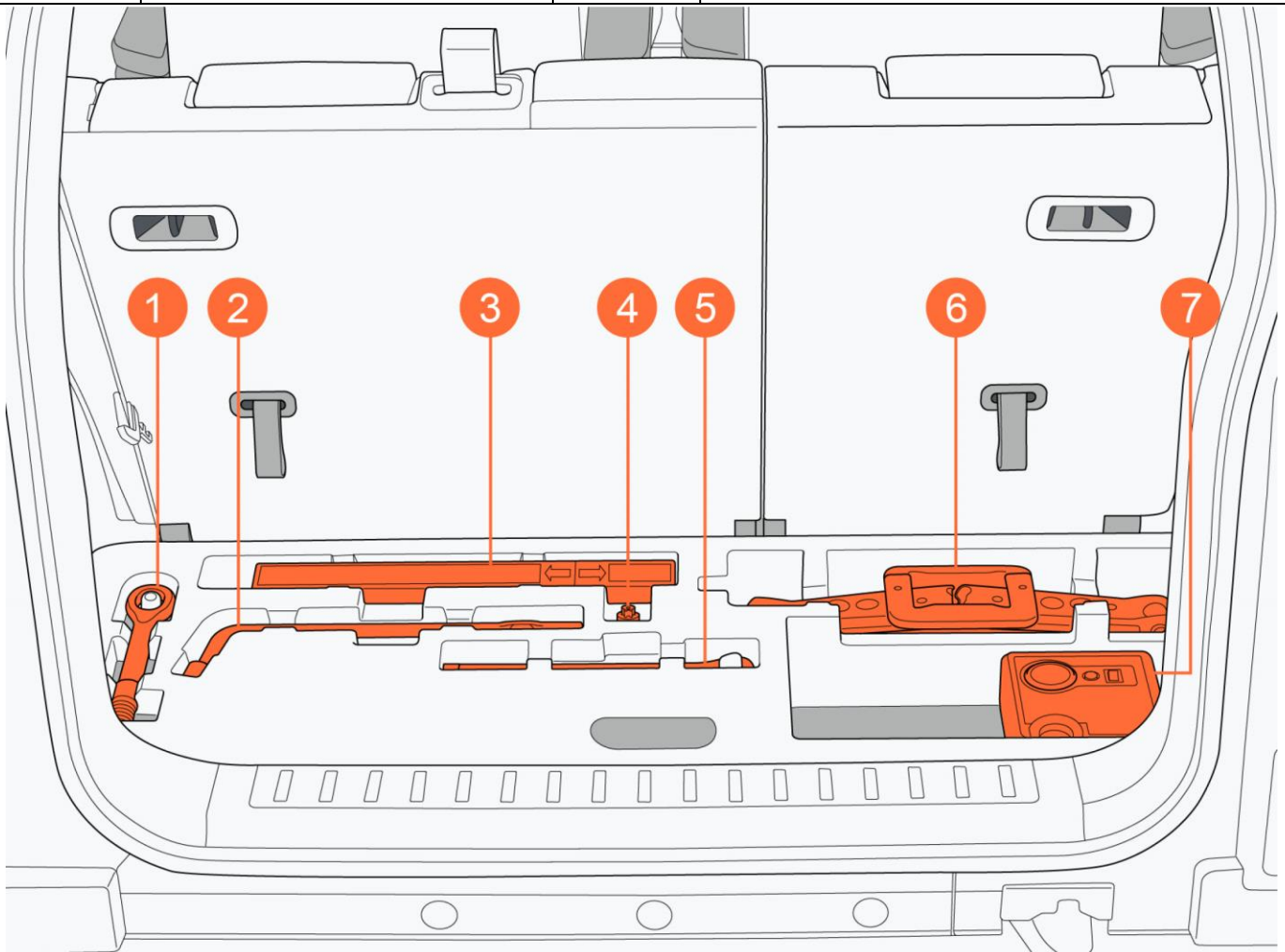



## 9 In case of fault

### 9.1.2 Hazard warning light

#### I. Hazard warning light switch

Press the hazard warning light switch, and all turn signal lamps and the turn signal indicators inside the instrument panel will flicker simultaneously.

#### **i** Tip

- Press the switch again to turn off the hazard warning lights. The hazard warning lights will work regardless of the vehicle's power mode. If the vehicle power is in the "OFF" mode, please turn off the hazard warning lights to avoid draining the battery.

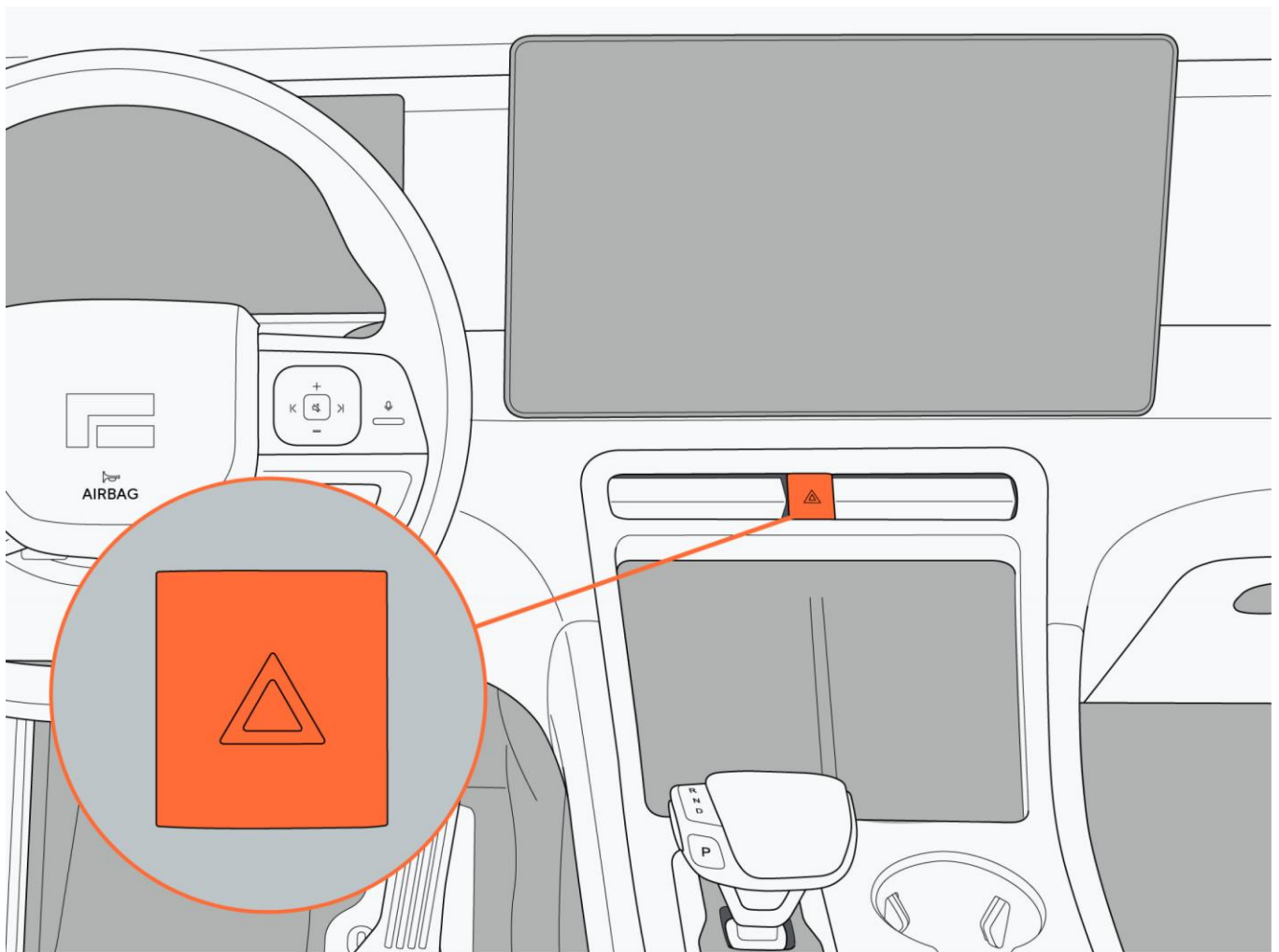

#### II. Emergency braking triggering hazard warning light

When the vehicle is in motion and an emergency brake is applied, the hazard warning lights will be triggered.

#### **i** Tip

- After the emergency brake hazard warning lights are triggered and the vehicle has stopped, they can be manually turned off or will automatically turn off when the vehicle is driven at a speed greater than 20 km/h.

#### III. Collision triggering hazard warning light

After a vehicle collision, the hazard warning lights will be triggered. To turn off them, press the hazard warning light switch.

### 9.1.3 Reflective vest

When dealing with vehicle faults at night or in low visibility conditions, take the reflective vest from the glove box, wear it properly, and then handle the vehicle. This can draw the attention of other drivers and enhance safety.

#### Warning

- When handling vehicle accidents, it is essential to wear the reflective vest as required to draw the attention of other drivers.
- If the vehicle is involved in an accident and parked on the side of the road, passengers should stay away from the parked vehicle while waiting for assistance to avoid secondary rear-end accidents.

#### Caution

- If the reflective vest is damaged or extremely dirty, it is recommended to replace it with a new one.

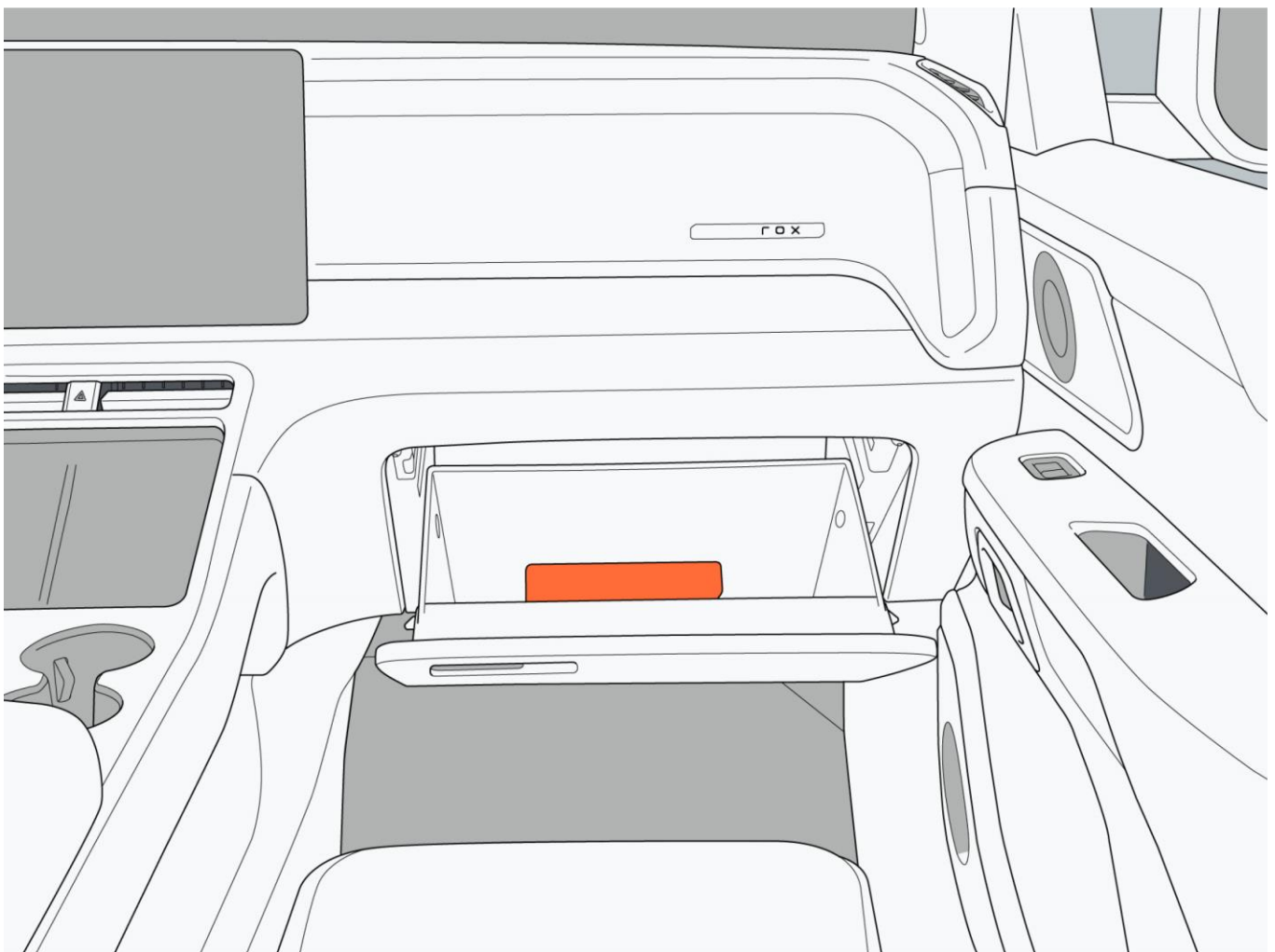

## 9 In case of fault

### 9.1.4 Warning sign

The triangular warning sign is stored in the trunk toolbox.

If the vehicle breaks down, take out the reflective vest from the glove box, wear it properly, and then place the warning sign behind the vehicle at a distance of 50 m to 150 m according to the road section, and turn on the hazard warning lights to warn the vehicles behind.

### 9.1.5 Vehicle needs towing

This vehicle is not suitable for towing with wheels landing on the ground. Please do not use the towing chain to directly tow the vehicle.

I. It is forbidden to use the following methods to tow a car:

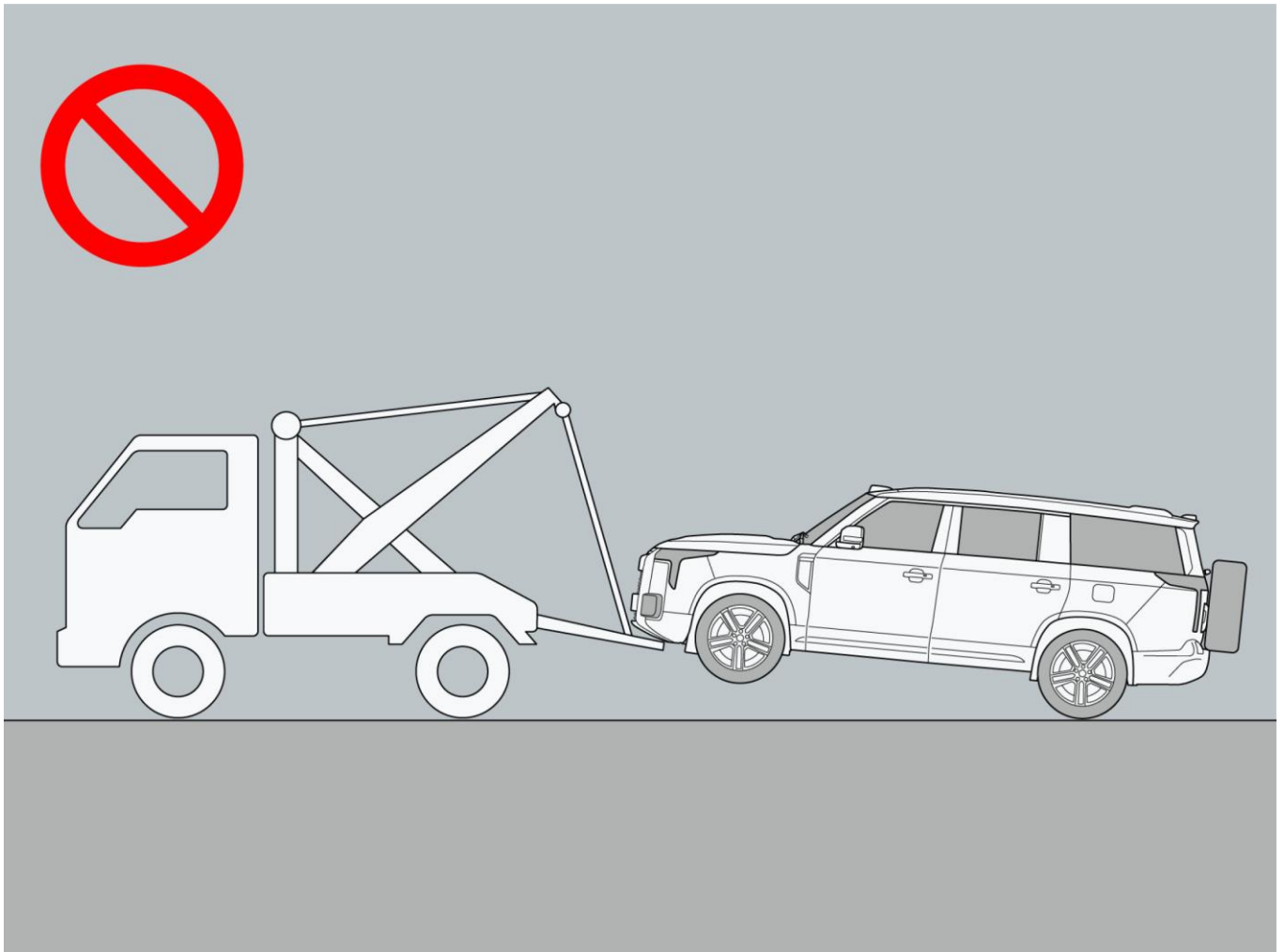

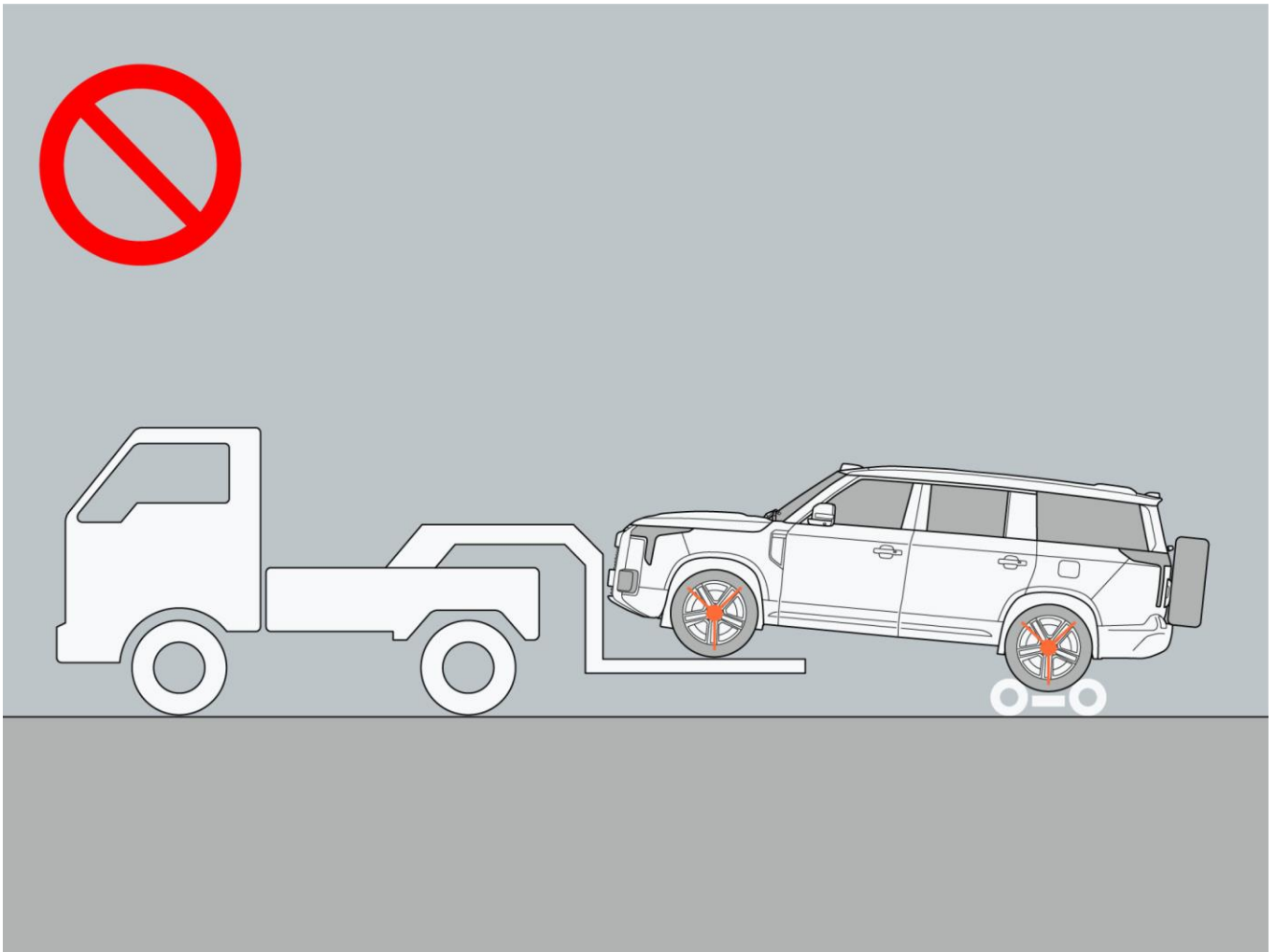

## 9 In case of fault

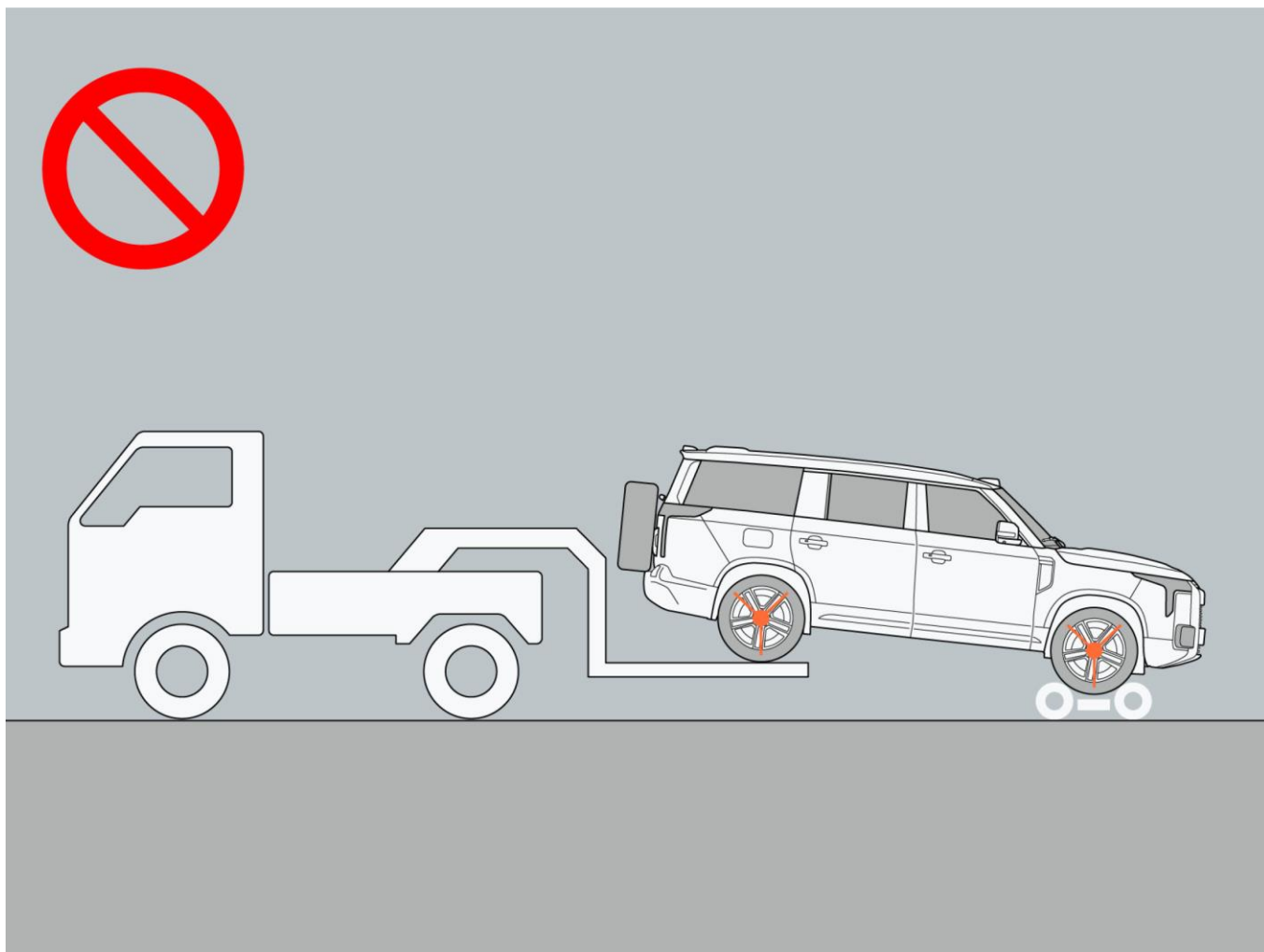

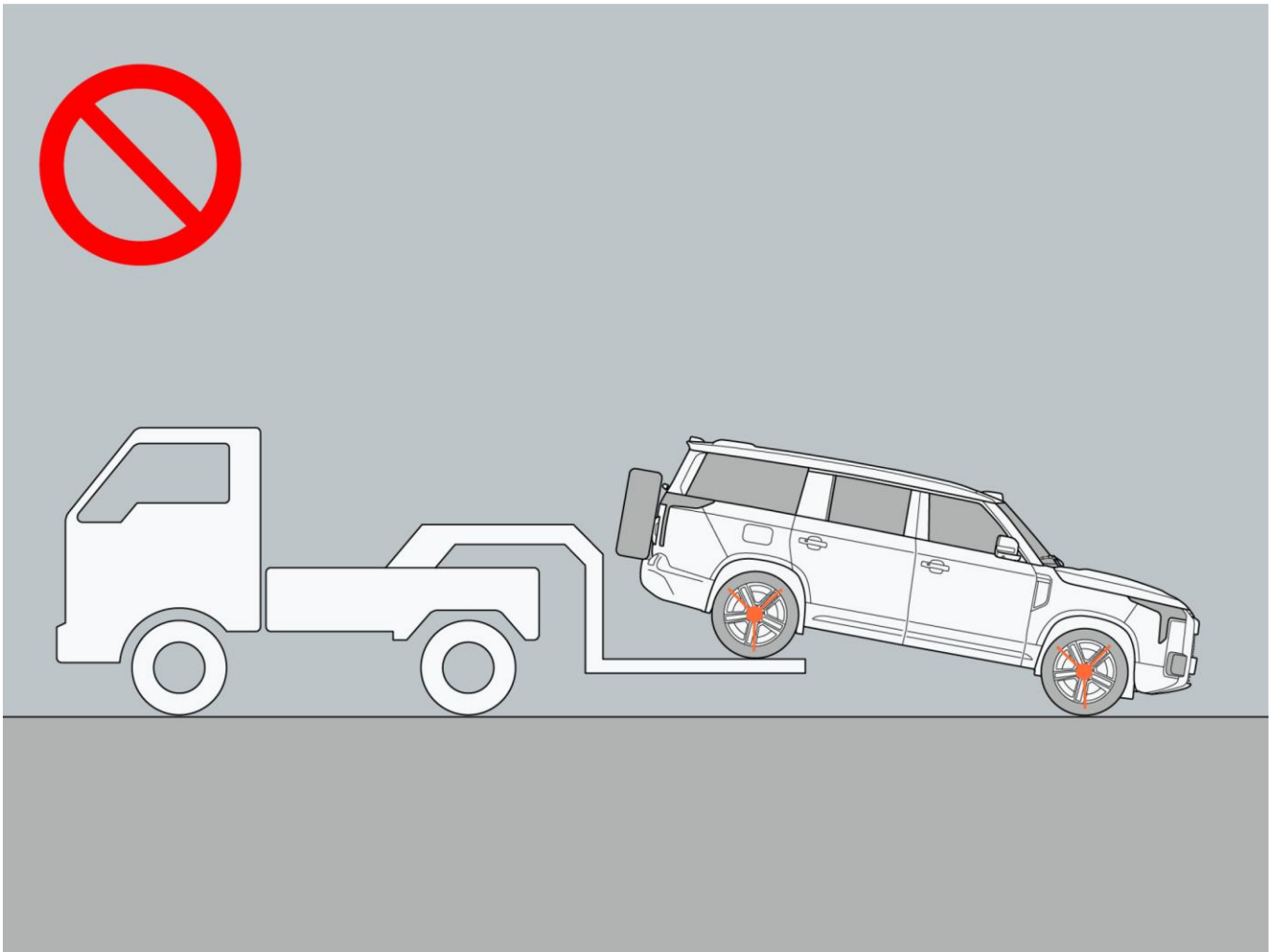

## 9 In case of fault

II. The vehicle can only be transported on a flatbed truck.

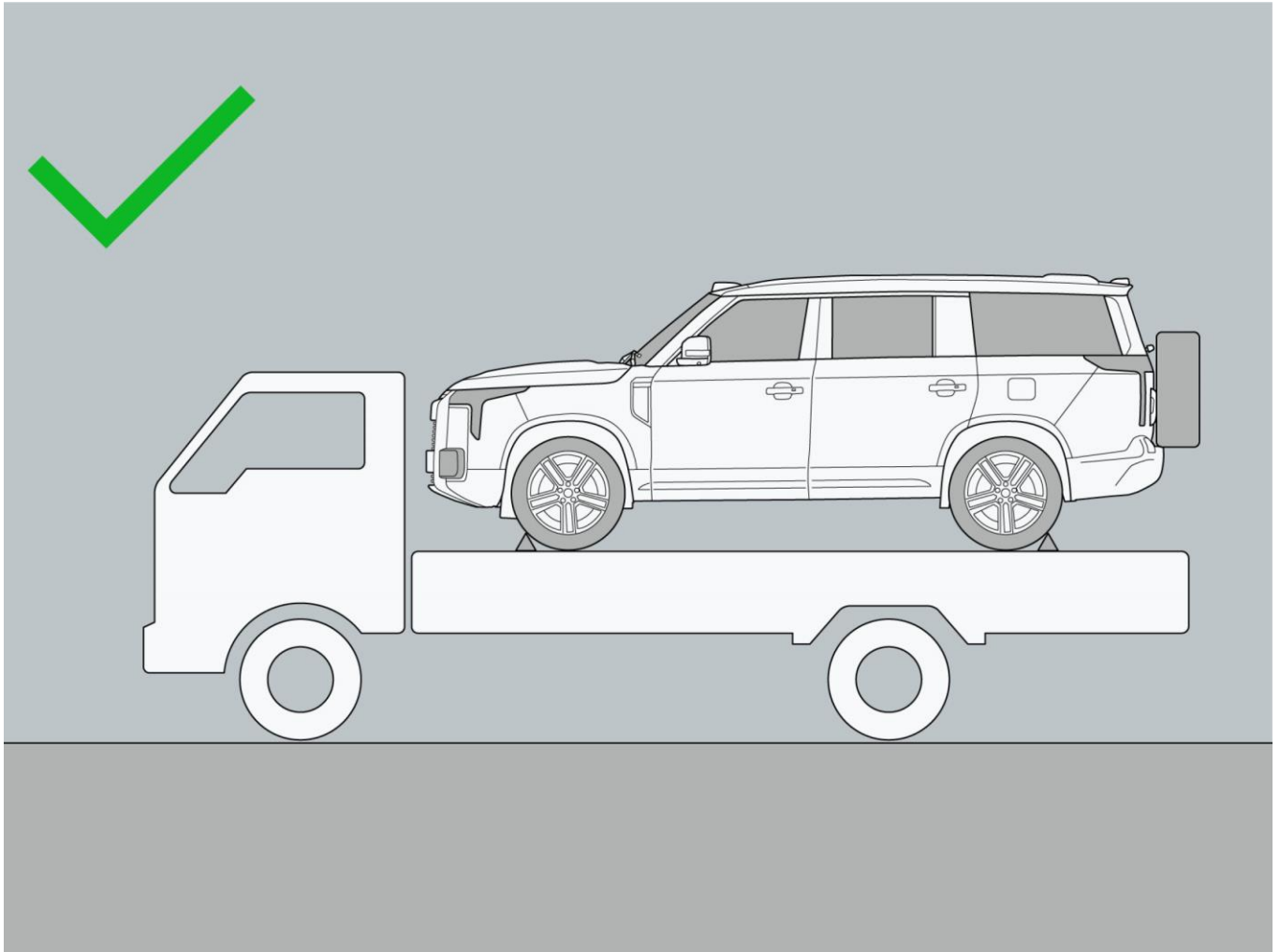

III. Towing mode

Press the brake pedal and. At the same time, click “Vehicle Settings → Vehicle → Driving → Towing Mode” on the central control screen to enable or disable the towing mode. When the vehicle needs to be towed, open the towing mode. During the towing mode, there will be system operation noise, which is a normal phenomenon.

To enable the towing mode, the following conditions must be met, otherwise, the towing mode cannot be enabled:

- The vehicle power is not in the “OFF” mode.
- The charger or external discharge adapter is not connected.
- The current vehicle gear is in P or N gear.
- The traction mode is in the closed state.

### Caution

- Before enabling the towing mode, ensure that the vehicle is stationary.
- After enabling the towing mode, the vehicle will lose its parking ability. Ensure that the vehicle does not slide to avoid safety incidents.
- After enabling the towing mode, the vehicle will not be able to enter the “READY” mode.
- After towing is complete, ensure to exit the towing mode and the vehicle is in a stable state.

#### IV. Emergency towing steps

1. Remove the tow hook from the trunk toolbox.
2. Press the tow hook cover on the left side to open the front tow hook cover.

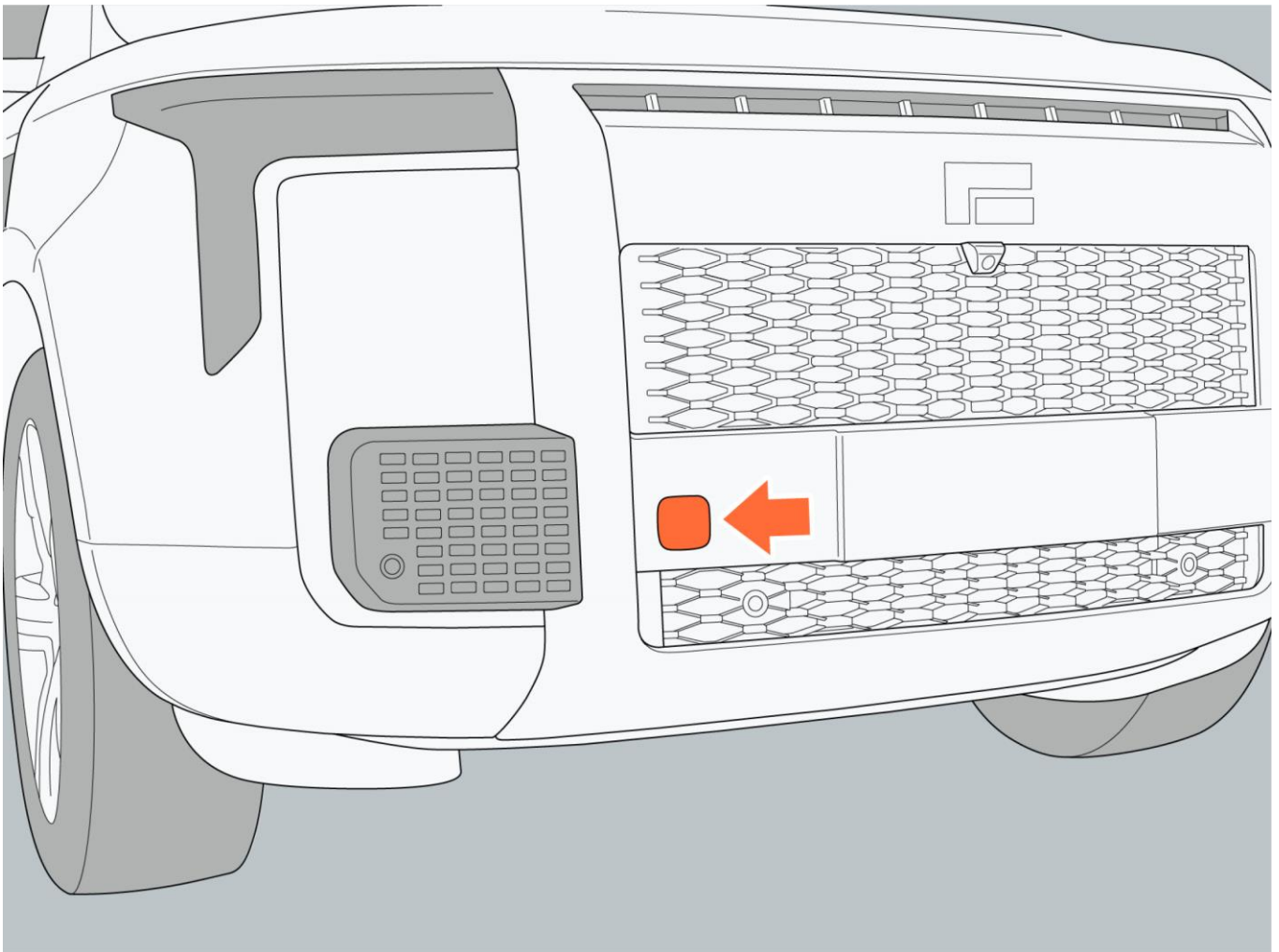



## 9 In case of fault

3. Take the tow hook from the trunk toolbox and screw it into the mounting hole in a clockwise direction.
4. Secure the steel cable or safety chain to the tow hook.
5. Enable the towing mode.

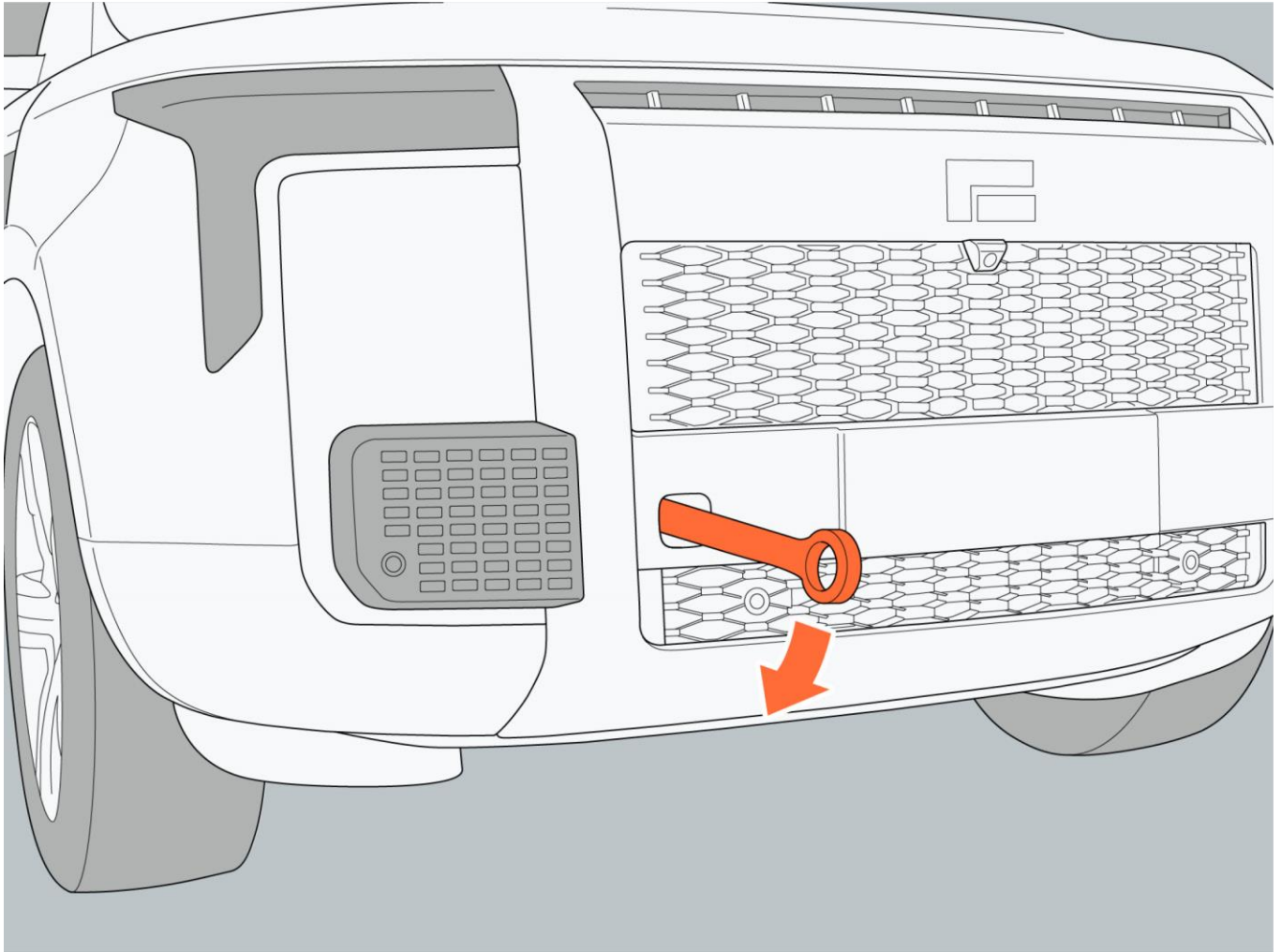

6. Have a professional tow the vehicle onto a flatbed tow truck and secure the vehicle.

### Warning

- Do not tow the vehicle while the tow hook is not securely installed, to avoid safety accidents.
- When towing the vehicle, do not stand on both sides of the tow rope.
- Only tow the vehicle away from the site when you are sure there is no safety risk. If the vehicle's battery pack is deformed, leaking, smoking, or in a similar state, safety risks should be eliminated first.
- During the towing process, do not turn off the towing mode. After towing onto the flatbed truck, the tires must be secured.

**i** Tip

- The rear towing operation method is the same as the front towing operation method.

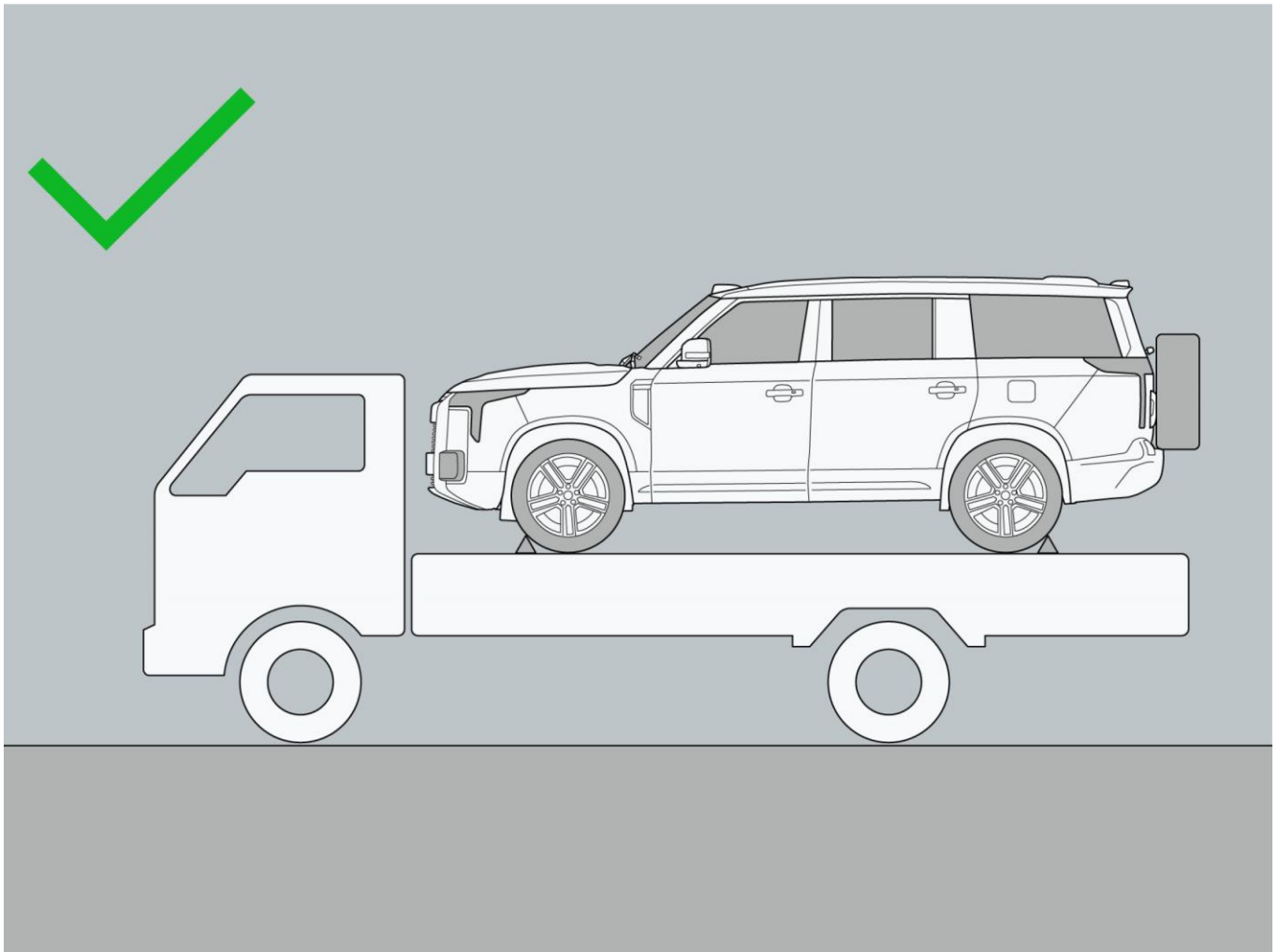

### 9.1.6 Inflation pump

1. Take out the inflation pump from the trunk toolbox.
2. Insert the inflation pump power cord into the 12 V power socket under the second row A/C control panel.
3. Unscrew the tire valve cover and connect the air hose to the tire valve.
4. Turn on the vehicle power, press the inflation pump power switch to inflate the tire. Observe the tire pressure through the inflation pump pressure gauge. When the tire pressure reaches the specified pressure indicated by the tire pressure label, turn off the inflation pump and turn off the vehicle power.
5. After inflation, place the inflation pump back in the trunk toolbox.

**⚠** Warning

- Do not continue driving with tire pressure that is too high or too low, to avoid accidents and personal injury.
- Do not continue driving with a flat tire, even for a short distance, as it can cause irreparable damage to the tire and wheel, potentially leading to an accident.

## 9 In case of fault

### 9.1.7 Tire changing operation

During tire change operations, park the vehicle on a safe, hard and flat surface. Switch the vehicle gear to P, enable the electronic handbrake, and switch the vehicle power to “OFF” mode. Turn on the hazard warning lights, wear a reflective vest, and place warning signs. Confirm the safety of the vehicle’s surroundings before proceeding with the tire change operation.

#### I. Steps for changing a tire

1. Remove the jack, wheel wrench and anti-theft bolt adapter from the trunk toolbox.
2. After taking out the tools, close the trunk, remove the spare tire cover, and connect the wheel wrench with the anti-theft bolt adapter to remove the anti-theft bolts. Unscrew the spare tire fixing bolts counterclockwise and remove the spare tire.

#### **i** Tip

- When removing the spare tire, avoid it from scratching the rear camera.

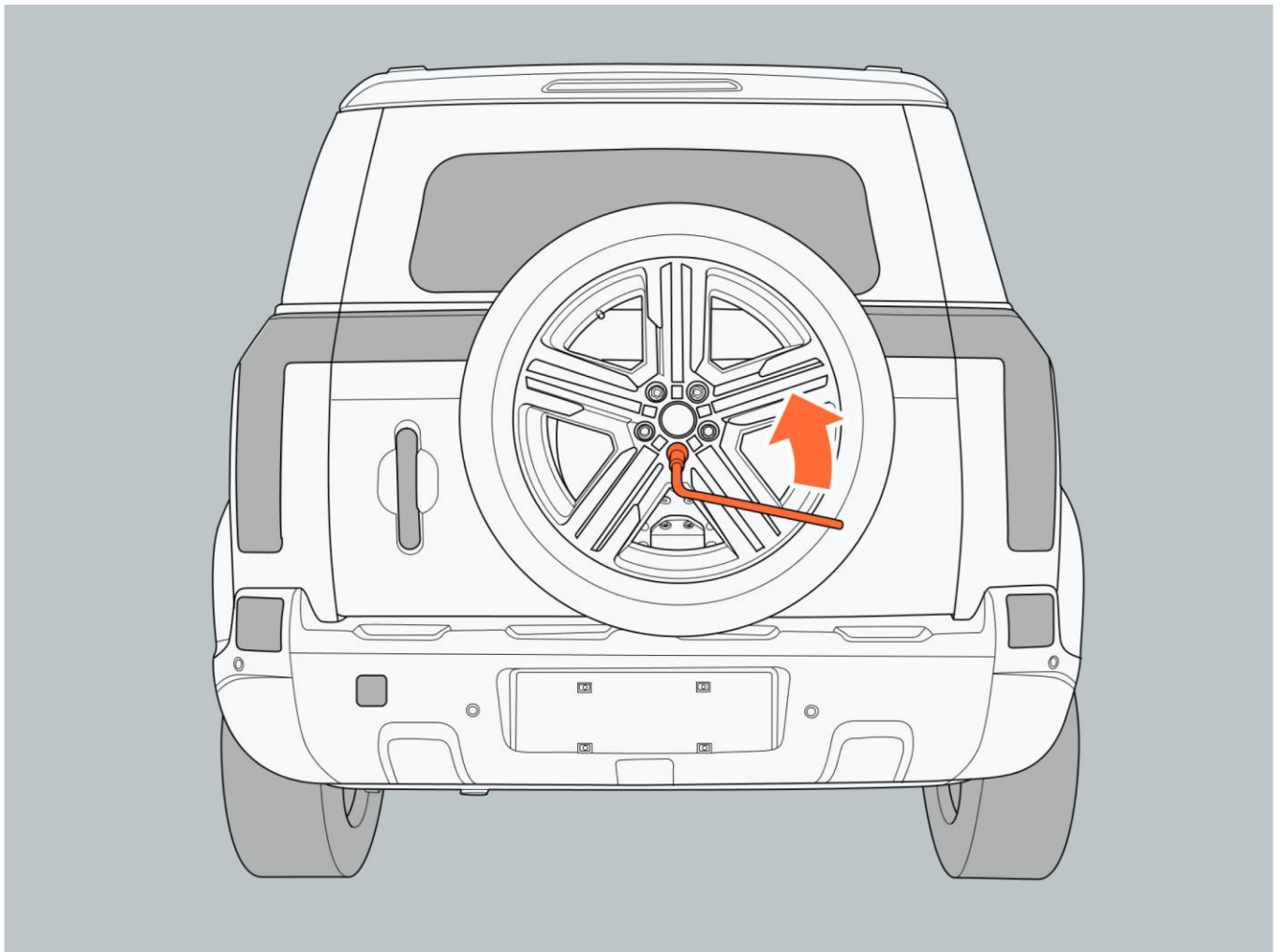

3. After removing the spare tire, place stoppers in front and behind the tire on the diagonal from the flat tire to prevent the vehicle from sliding.
4. Loosen the wheel bolts by turning them counterclockwise with the wheel wrench.

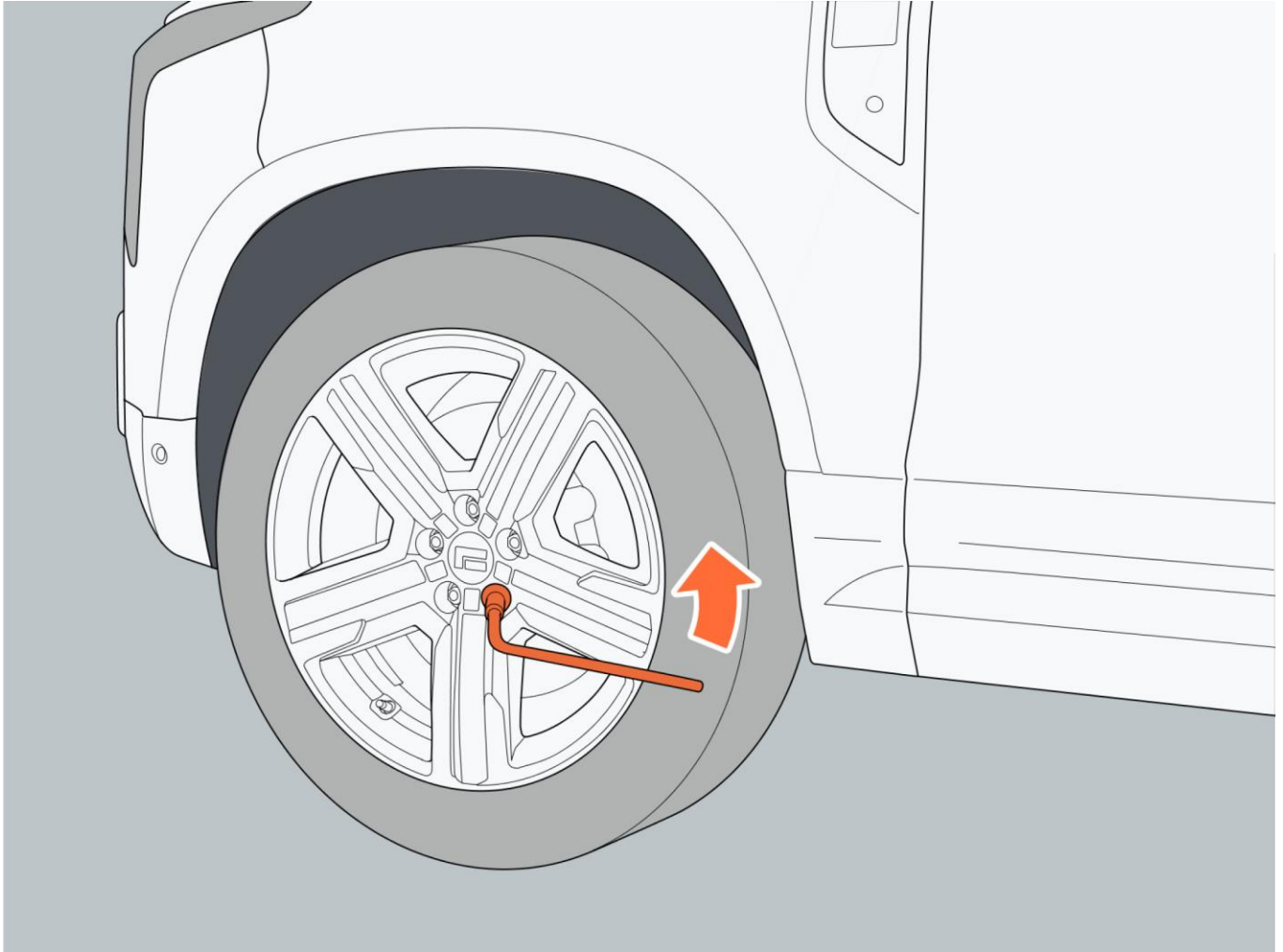

5. Place the jack at the lifting point (refer to the operation mode of the jack mark), and lift the vehicle to the height where the tire can be changed. When the jack is about to lift the vehicle, check again that the jack's position is at the correct lifting point.

## 9 In case of fault

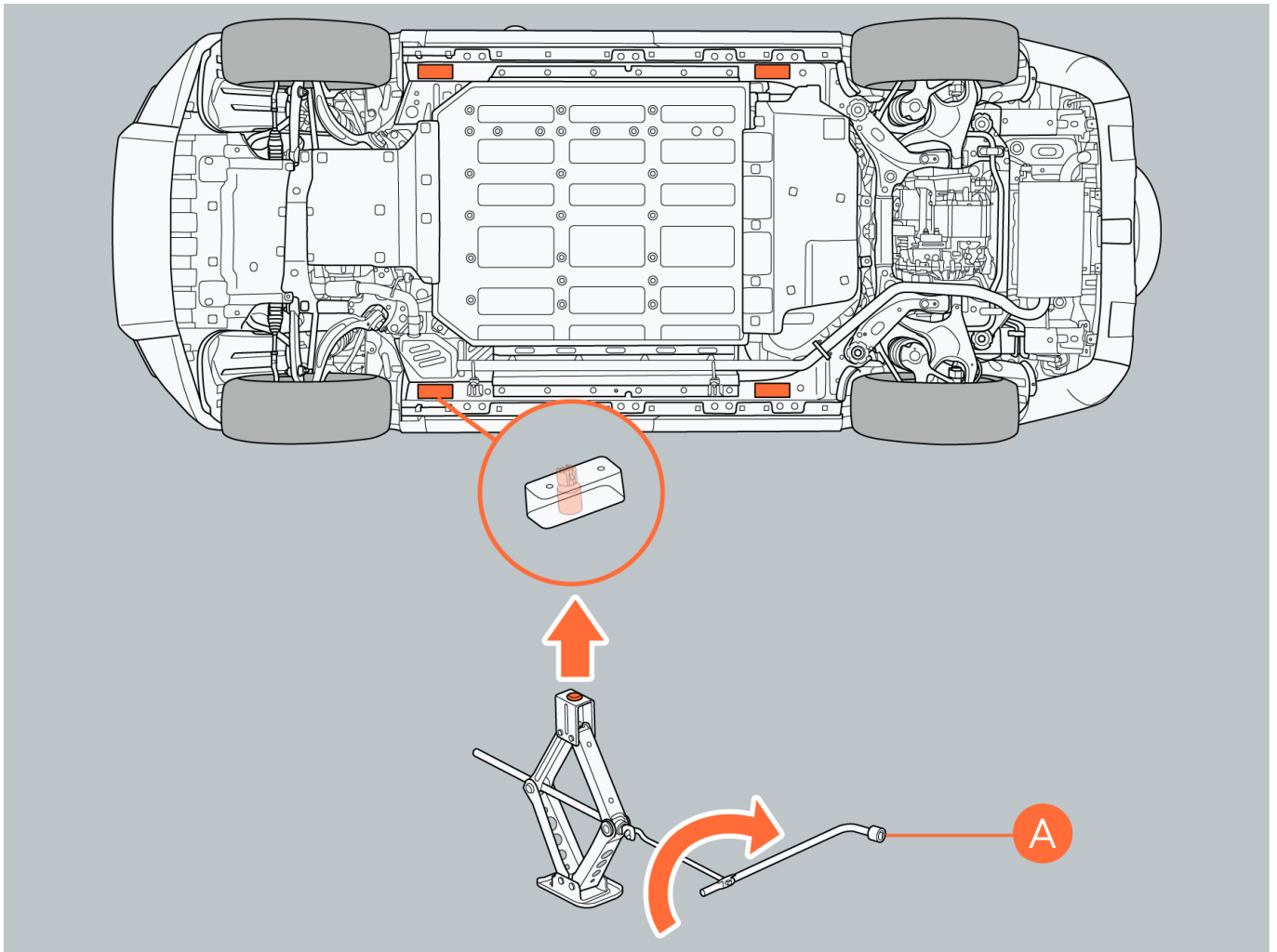

- a. Turn the tire jack "A" position by hand until the top boss of the jack completely enters the pit of the vehicle support block.
- b. Raise the vehicle so that the tire is slightly off the ground.

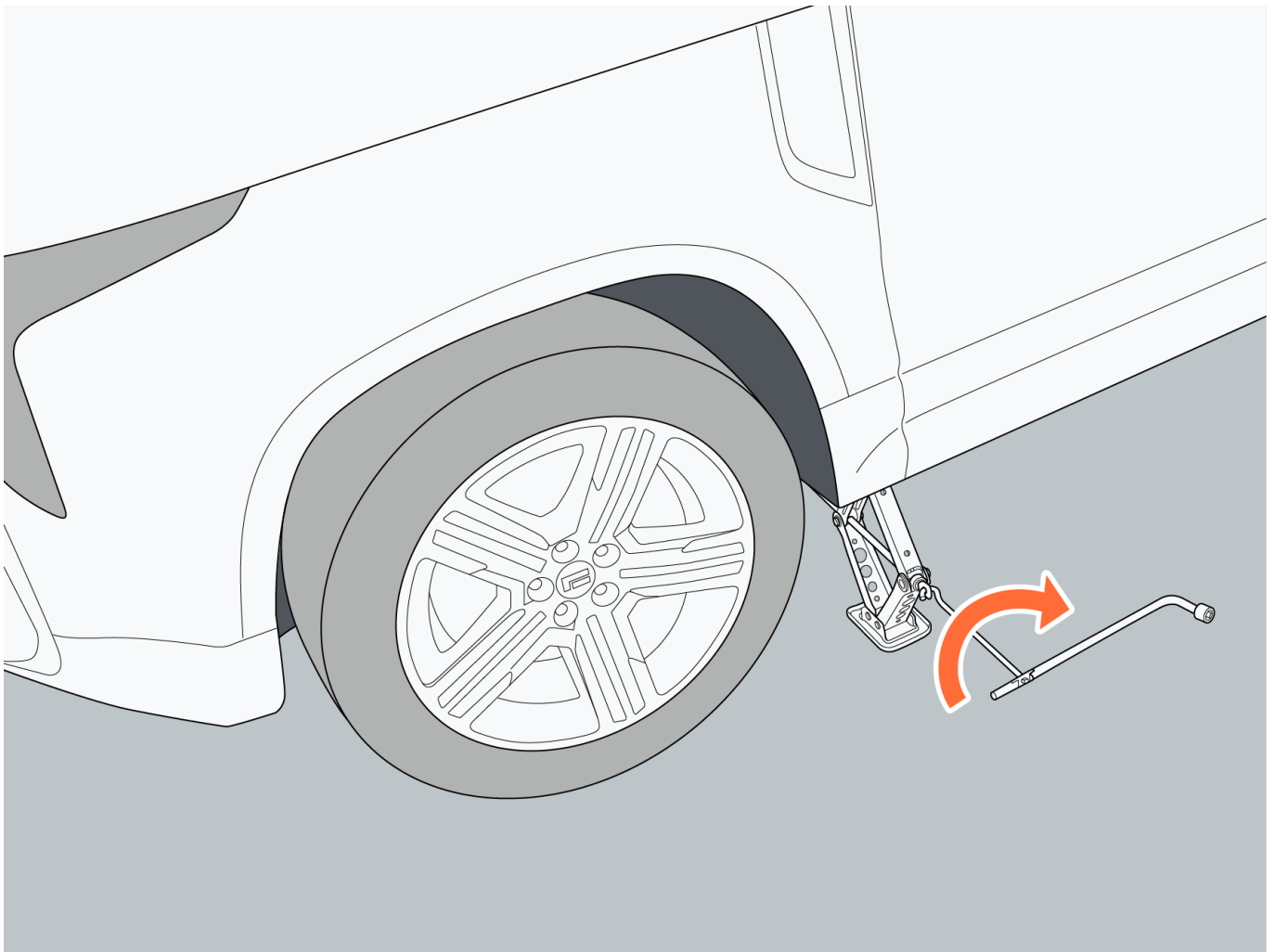

 Caution

- When using a jack, always observe the following. Otherwise, it is easy to damage the vehicle or cause the jack to shift, resulting in serious personal injury:
- Be sure to turn off the engine.
- Do not use the jack when the vehicle is carrying passengers.
- The jack must be placed on a flat, hard surface.
- Do not place items on the top or bottom of the jack.
- The lifting height of the jack should not be too high. It should be suitable for changing the tire.
- When using the jack, ensure that the jack adjusting rod is coaxial with the jack lead screw rotation center. When operating, slightly jack the vehicle and carefully check for any abnormalities before continuing to slowly lift the vehicle.



## 9 In case of fault

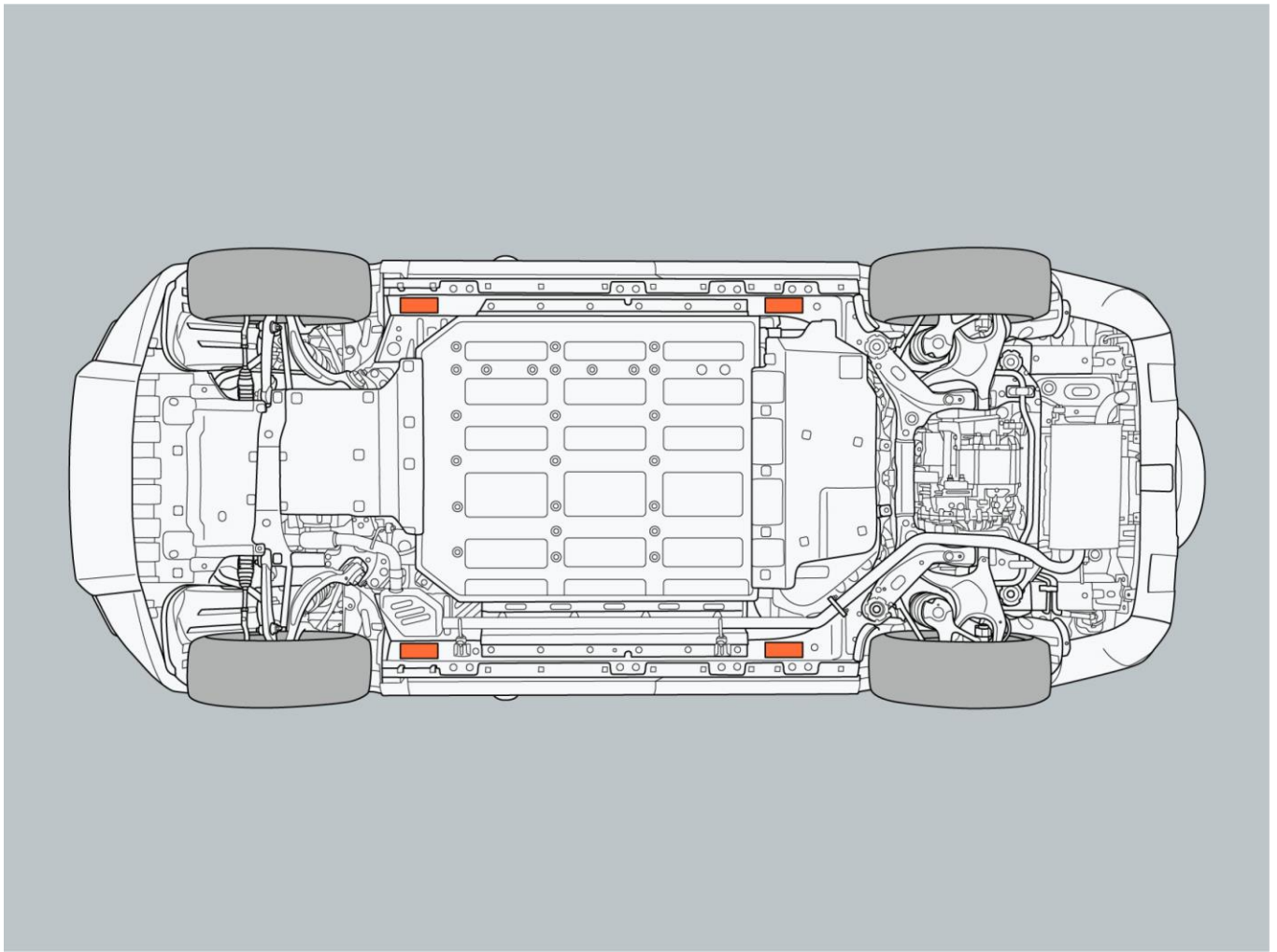

6. Remove the wheel bolts and replace the tire. When installing the tire, align the bolts with the mounting holes and ensure the tire metal surface contacts the mounting surface normally.

### Caution

- When placing the tire directly on the ground, place the spoke rim face up to avoid damage.
- Before installing the spare tire, it is best to place the removed tire under the vehicle to prevent the jack from shifting, causing an accident.

7. After installing the wheel bolts and lightly tightening them, lower the vehicle and remove the jack. Tighten all wheel bolts in a diagonal crisscross order with the wheel wrench, then tighten the wheel bolts to 160 Nm with the torque wrench.

8. Check the tire pressure of the replaced tire and inflate it appropriately if necessary.

### Warning

- When using a jack, do not place it on the wrong support point to avoid damaging the vehicle.
- When the jack is lowering the vehicle, be aware of your surroundings to avoid pinching the operator or other people around.
- If the vehicle is equipped with side pedals, the jack cannot directly lift the side pedals to avoid damaging the side pedals, and can only lift the lifting point of the vehicle.

### Caution

- Non-spare tire models are not equipped with a spare tire. If a tire needs to be replaced, use a tire of the same specification and tread pattern.

### 9.1.8 Power system fails to start

I. Vehicle can drive normally but range extender cannot start

Possible causes:

- There may not be enough fuel in the fuel tank, and the instrument panel displays a low fuel warning icon.
- If the range extender system fails, the instrument panel displays a power system fault warning icon.

II. Vehicle cannot start normally and range extender cannot start

Possible causes:

- The remote key battery may be low and unable to work.
- The battery may be depleted.
- Vehicle electrical fault.

### Tip

- If the above faults occur, please contact the ROX Service Center and park the vehicle in a safe area.

III. Emergency start-up powertrain

When the remote key battery level is too low, you can start the powertrain by following steps:

1. Open the door with the mechanical key.
2. Place the remote key in the storage pot on the center console.
3. Check and confirm that the vehicle is in P gear.
4. Press the brake pedal, and the READY indicator turns on.

### 9.1.9 Battery level depleted

If the battery fails or the interior lighting cannot be turned off due to a fault, resulting in the battery being depleted and unable to start the vehicle normally, please contact the ROX Service Center.

### Caution

- Jump starting between this vehicle and another vehicle is prohibited to avoid damaging the battery.

### 9.1.10 Vehicle overheating

I. Vehicle overheating

1. The instrument panel displays a high temperature warning light for the range extender.
2. The power of the powertrain is reduced (e.g., unable to increase vehicle speed).
3. Steam comes out from under the hood.



# 9 In case of fault

## II. Countermeasures

1. After parking the vehicle in a safe location, turn off the A/C system and disconnect the vehicle's power supply.
2. Turn on the hazard warning light.
3. Take the reflective vest from the trunk toolbox and wear it correctly.
4. Place the warning sign in a suitable position for the vehicle.
5. After the powertrain has cooled down sufficiently, open the hood.
6. Check if the coolant level is within the normal mileage. If the level is within the normal mileage, drive the vehicle to the ROX Service Center for inspection under safe conditions. If the level is not within the normal mileage, please contact the ROX Service Center immediately.

### Warning

- Do not open the coolant filling cap when the coolant temperature is high, to avoid scalding.
- Do not open the hood when steam is coming out from under it, to avoid scalding.

### Tip

- If the coolant level in the expansion kettle is between the "MAX" and "MIN" indicator lines, it indicates that the level is normal. If the level is not between the "MAX" and "MIN" indicator lines, it needs to be added or discharged to the normal mileage.

## 9.1.11 In case of vehicle getting stuck

### I. Vehicle escape

If the tires are spinning or the vehicle is stuck in mud or snow, perform the following operations:

1. Switch the vehicle gear to P.
2. Clear the mud or snow trapped around the wheels.
3. Place wooden blocks, stones, or other items that can help increase the friction of the wheels under the stuck wheels.
4. Select an appropriate driving mode for the current road by clicking the ROX Mode at the bottom of the central control screen.
5. Gently press the accelerator pedal and slightly turn the steering wheel to help the vehicle get unstuck.

When performing escape, follow the following precautions to avoid vehicle damage and even endangering personal safety:

1. When using the tow hook for towing, a flag must be tied in the middle of the tow rope to prevent the tow hook or rope from breaking and rebounding, causing vehicle damage, or even endangering personal safety.
2. It is prohibited to tow from the side or at a vertical angle. The best towing angle for the tow hook is within a range of 5° up and down, and 25° left and right.

3. Ejection towing is prohibited. The initial towing speed should not exceed 5 km/h (start slowly until the tow rope is tightened).
4. When using the vehicle tow hook for towing, the towing traction should not exceed 16 kN.

### Warning

- Do not use the above methods for escape in areas where the vehicle surroundings are narrow.
- Do not operate the gear shift lever when pressing the accelerator pedal, to avoid sudden acceleration causing an accident.

### Tip

- If the vehicle cannot be escaped after following the above steps, contact the ROX Service Center.

## 9.1.12 Emergency Call

### I. Emergency Call (E-Call)

The vehicle is equipped with an emergency call (E-Call) system. When an accident or emergency occurs, the “SOS” function can be activated manually or automatically to obtain rescue from the local road emergency rescue management center.

### II. Manual call

Press the “SOS” alarm button continuously for 3s, or press the SOS button 5 times in quick succession within 10s, to trigger the emergency call function. The vehicle’s status information (location, time, vehicle characteristics, etc.) is automatically sent to the local road emergency rescue management center. This facilitates the rescue center to carry out rescue.

## 9 In case of fault

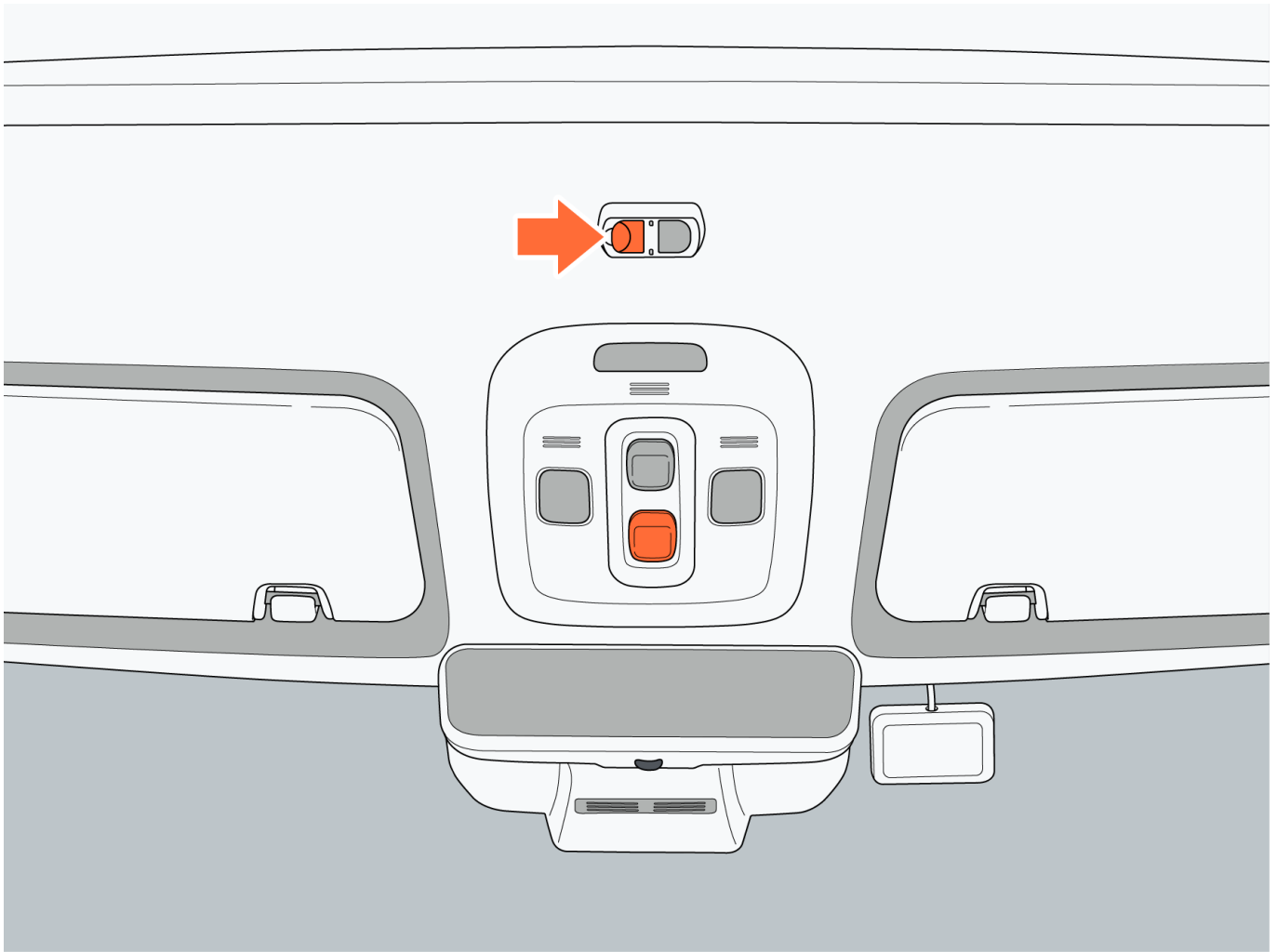

### III. Cancel a manual call

After initiating a manual emergency call with a long press of 3s, the indicator will flash orange-red slowly. The slow flash will last for 6s. Within the 6s period, pressing the SOS button for more than 1s and then releasing it will cancel the manual emergency call.

#### Caution

- Only a manual emergency call initiated with a long press of 3 s can be canceled. Emergency calls triggered in different ways cannot be canceled.
- This function should only be used in emergency situations, such as accidents, illness or threats to occupants.

### IV. Automatic call

When the vehicle sensors detect a collision, rollover, or other accidents, or when the vehicle system receives information about an accident, the alarm function will be automatically triggered. The vehicle's status information (location, time, vehicle characteristics, etc.) is automatically sent to the local road emergency rescue management center. This facilitates the rescue center to carry out rescue.

### V. Indicator instruction

Working status	Instruction
----------------	-------------

## 9 In case of fault

Off status	Total indicator runout
Normal standby operation	"SOS" key white backlight always on
E-Call fault	Red indicator always on
Emergency call center	Green indicator flickering
Emergency call connected	Green indicator always on
Terminating emergency call center	Red indicator flickering
Mode testing	Orange indicator flickering
Self-check	Orange and backlight flashing

## 9 In case of fault

### 9.2 Accident rescue

#### 9.2.1 Appearance identification information

Identify this electric vehicle through its external features: (Type 1)

1. The "EV 01" logo on the right side of the trunk door panel.
2. Charging port cover.

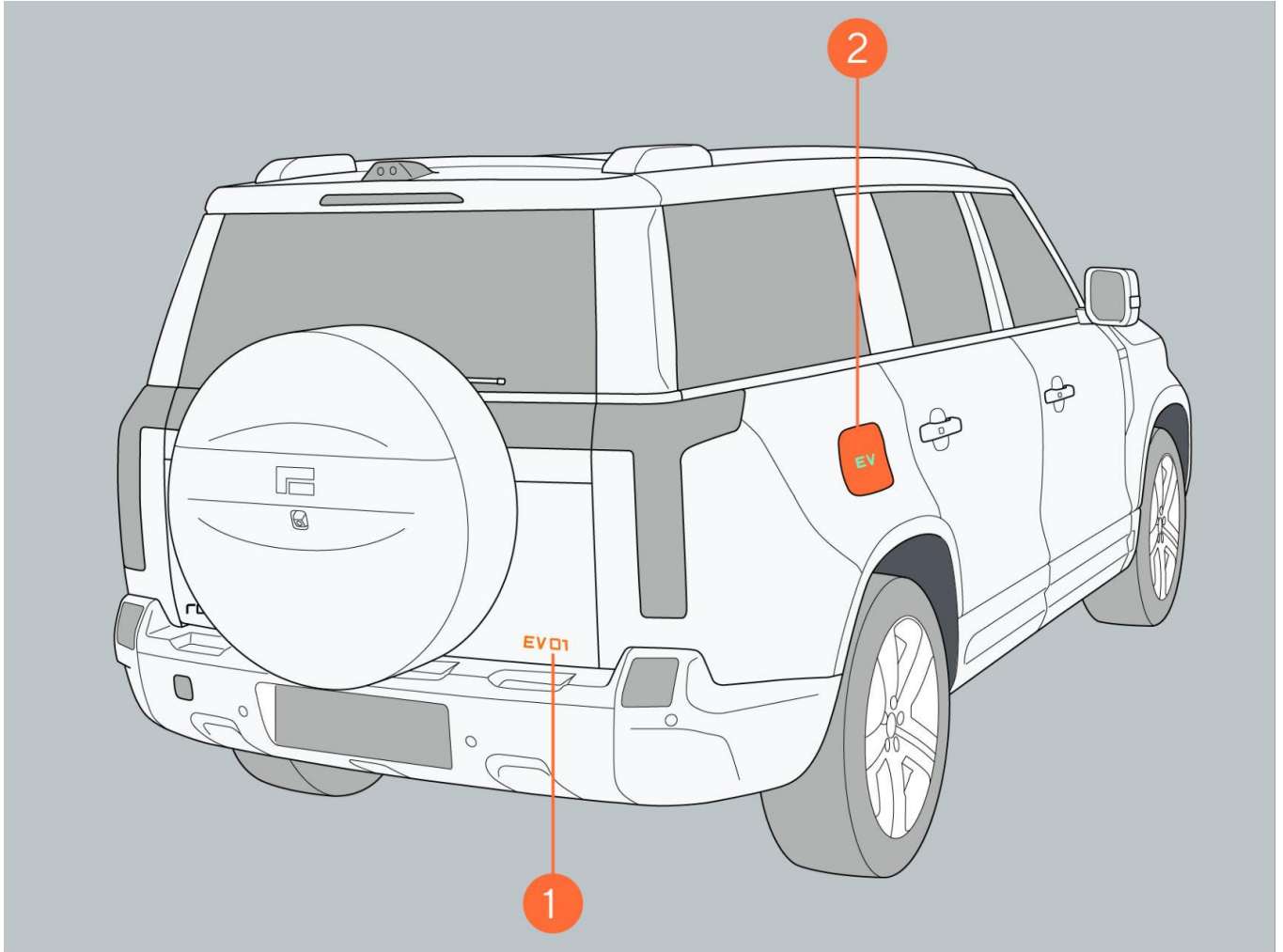

Identify this electric vehicle through its external features: (Type 2)

1. The "01" logo on the right side of the trunk door panel.
2. Charging port cover.

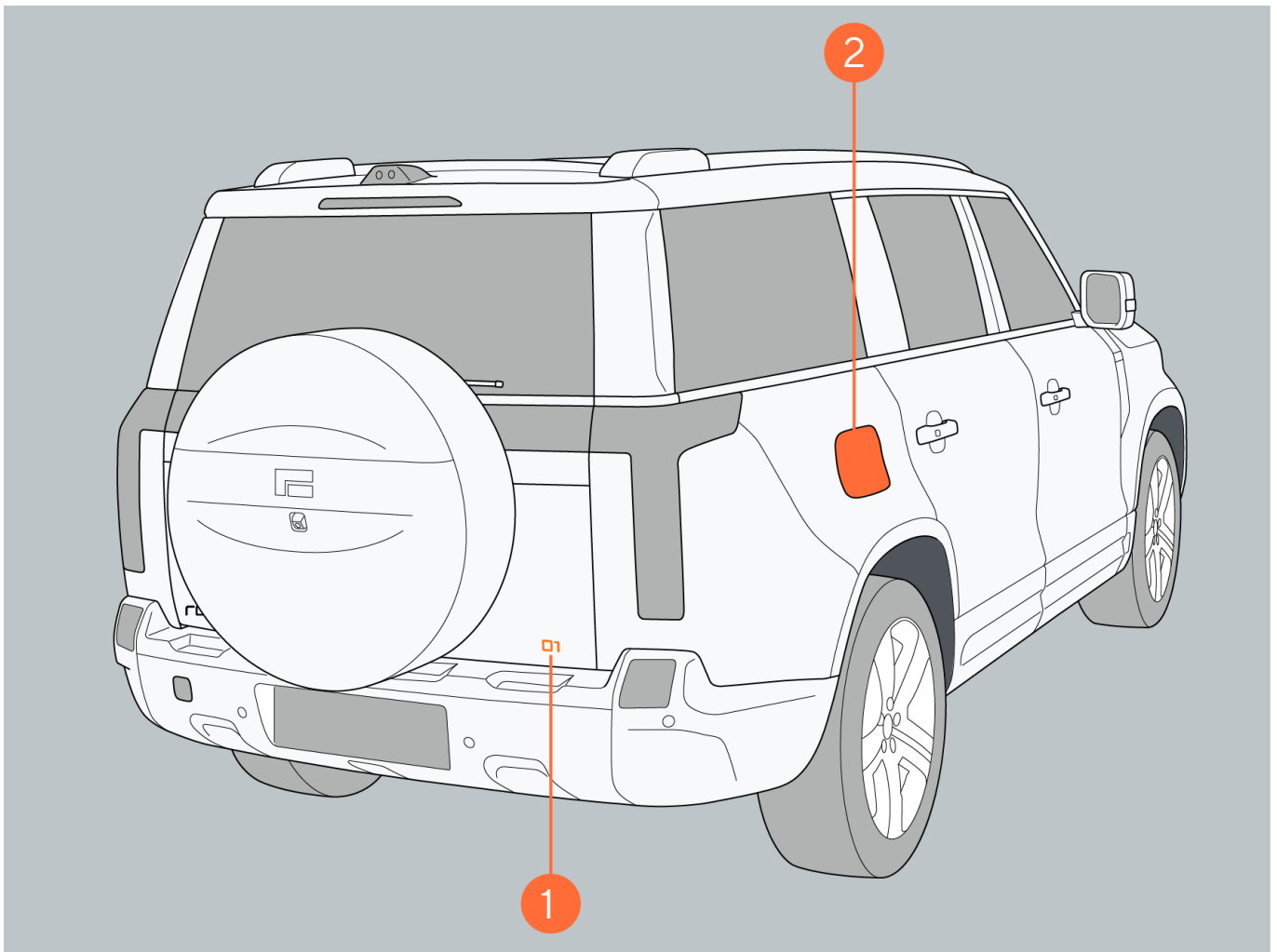

### 9.2.2 Rescue protection device

The powertrain of the vehicle is driven by high-voltage batteries. In the event of a serious collision, there may be a risk of electrical leakage or battery electrolyte leakage. Therefore, when performing vehicle rescue operations, professional rescuers should wear protective devices for rescue operations.

#### I. Physical protection

When rescuing the vehicle, please wear the following protective equipment to prevent electrical accidents:

- High-voltage insulating gloves (natural rubber insulating 1,000 V or more).
- Goggles.
- Insulated rubber shoes.
- Insulating mat (can be used as an alternative if there are no insulating rubber shoes/boots).
- Tools with insulating protective sleeve.

#### II. Chemical protection

If the battery leaks, please wear the following protective equipment to avoid injury to the face, skin, etc.:

- Protection mask.
- Solvent insulating gloves.

## 9 In case of fault

### Warning

- When performing rescue operations, please take off the metal products (such as necklaces, watches, etc.) on the body to prevent electric shock.

### 9.2.3 Emergency cut-off high voltage system

Before performing high-voltage operations on the vehicle, such as troubleshooting, assembly, maintenance and rescue, the vehicle's high-voltage system must be powered off.

Click "Vehicle Settings → General → System Information → Version Information" on the central control screen to query the current vehicle version information

If the version information is V1.2.b or higher than V1.2.b, use Method 1:

Manually shut down the high-voltage power supply by clicking "Power Off" under "Vehicle Settings → Vehicle → Driving → Vehicle Power" on the central control screen.

If the version information is lower than V1.2.b, use Method 2:

1. Disconnect the vehicle's external high-voltage charging connection, such as the charger.
2. Turn on the vehicle's Bluetooth and connect the vehicle Bluetooth to your phone's Bluetooth.
3. Click the communication icon on the central control screen to enter the communication application.
4. Enter the communication application, input `**#800800#` in the dialing pad, and then enter the engineering mode.
5. After entering the engineering mode, click the "One-click Off" function bar on the left, and click "One-click Off" on the right to cut off the high-voltage system. Click "One-click On" to restore the high-voltage system.
6. After the vehicle's high-voltage system is powered off, disconnect the negative terminal of the battery.

### Warning

- Do not perform high-voltage work such as troubleshooting, assembly, maintenance and rescue when the vehicle is not powered off, to avoid electric shock.

### 9.2.4 Vehicle fire rescue

When the vehicle is on fire, take the following rescue measures:

1. If you find smoke or fire while driving, stop the vehicle immediately and have all passengers leave the vehicle.
2. If you find smoke or fire while the vehicle is stationary, evacuate the surrounding people immediately. If the vehicle is charging, press the emergency switch on the charging station immediately to stop the vehicle from continuing to charge.
3. If the fire is not very intense, the on-site personnel should use dry powder or foam fire extinguishers to put out the fire as soon as possible to prevent the fire from expanding.
4. If the fire is intense, professionals should wear protective devices to put out the fire.

#### Warning

- If the vehicle is on fire, do not touch any part of the vehicle. Professionals should wear protective devices for rescue.
- The gas stored in the side curtain airbag cylinder and the high-pressure air suspension cylinder may expand due to heat in high-temperature and may explode. Please be extremely careful before performing any operation to avoid personal injury.



# 9 In case of fault

## 9.2.5 Vehicle wading rescue

It is recommended not to drive the vehicle in deep water for a long time to avoid damage to the vehicle's high-voltage system.

Under the premise that the vehicle body and chassis are not damaged, there will be no greater risk of electric shock due to immersion in water. However, professional rescue personnel need to wear appropriate rescue protective equipment. First pull the vehicle out of the water, and then cut off the high-voltage system immediately.

### Warning

- Do not touch the submerged vehicle without wearing protective equipment to avoid electric shock.

## 9.2.6 Battery leak rescue

When a high-voltage battery leaks, it may generate high temperatures or even cause a fire. Cool down the high-voltage battery before handling the leaked liquid.

### Warning

- When the battery electrolyte leaks, it should be handled by professional rescue personnel wearing protective masks and solvent-resistant gloves. Do not touch the liquid directly.
- When the battery electrolyte leaks, avoid contact with the electrolyte on the skin and eyes. In case of contact, rinse with a large amount of water for 15 min and seek medical assistance. Any person or animal is prohibited from swallowing any part of the battery and any substance contained in the battery.









## 9.2.7 Vehicle cutting area

When the vehicle needs to be cut, it should be performed by professionals with appropriate tools.

The high-voltage power, airbag and flammable areas of the vehicle are prohibited cutting areas, as shown in the figure below.

### Warning

- Do not cut vehicle parts randomly. If the vehicle needs to be cut, it should be done by professionals to prevent serious personal injury.

Icon	Name	Icon	Name
	High voltage part		Airbag controller
	Seat belt pretensioner		Stiffener
	Side air curtain cylinder		Fuel tank
	Gas spring		Airbag
	Low voltage battery		

Configuration 1

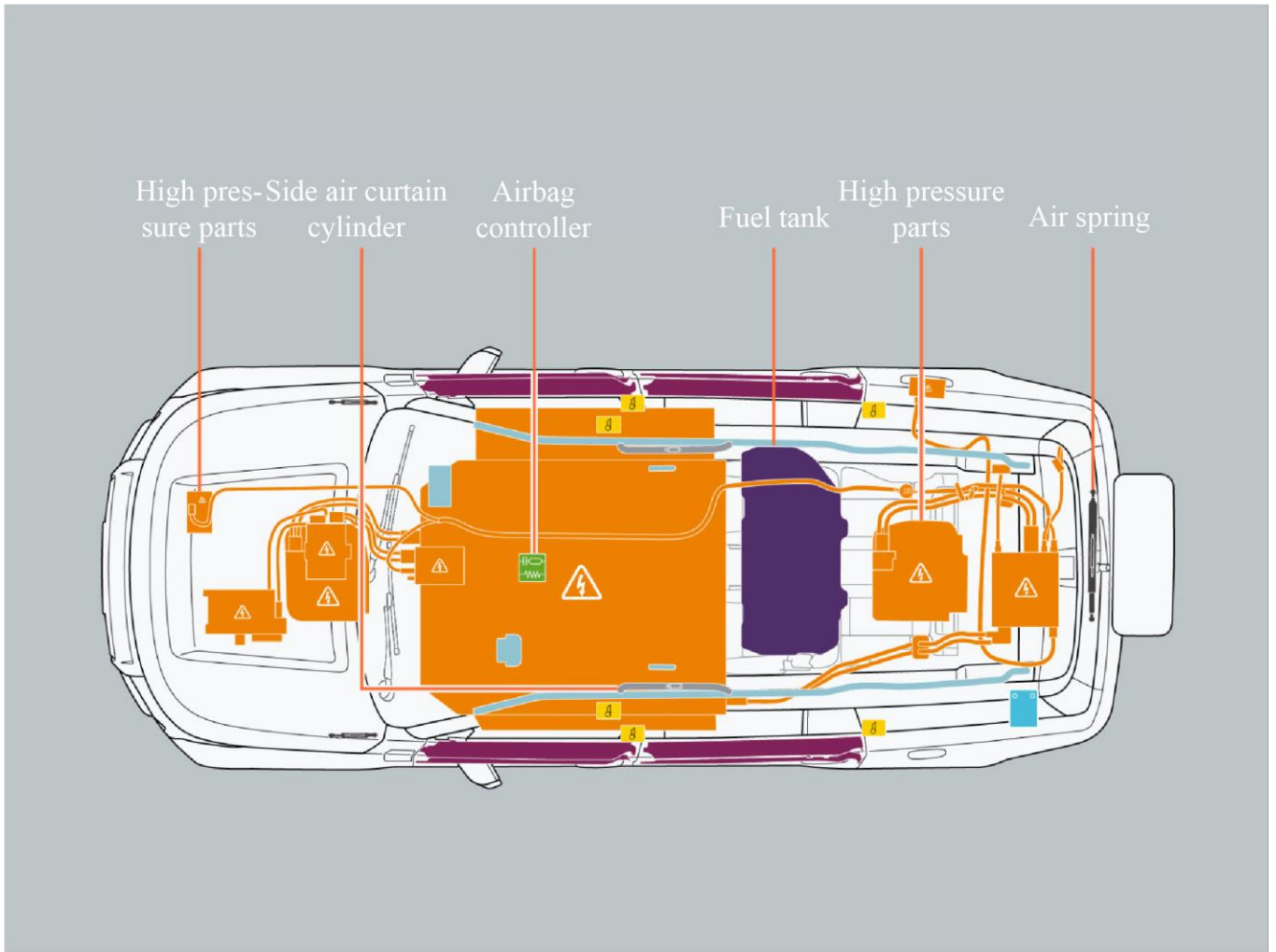

# 9 In case of fault

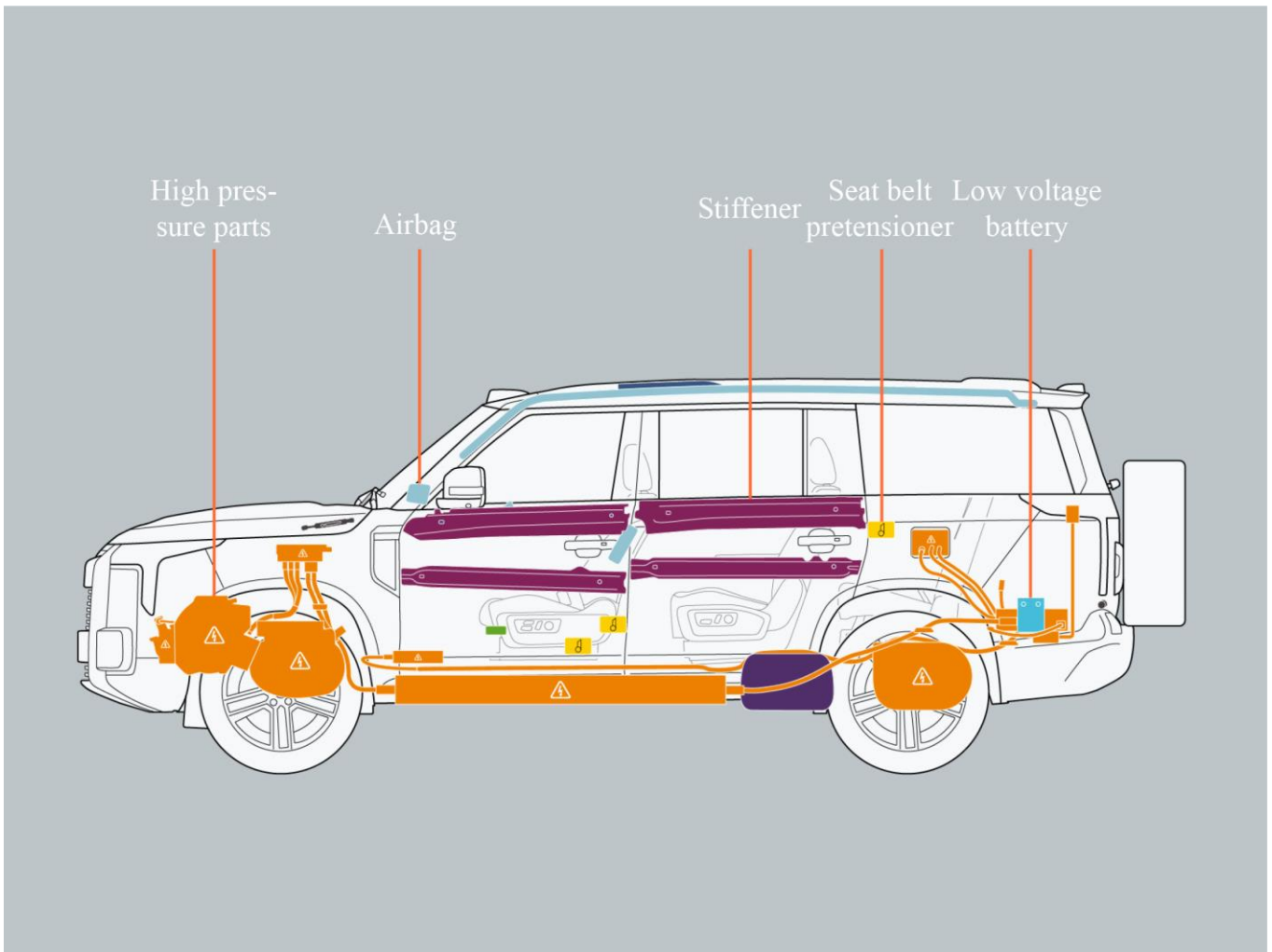

Configuration 2

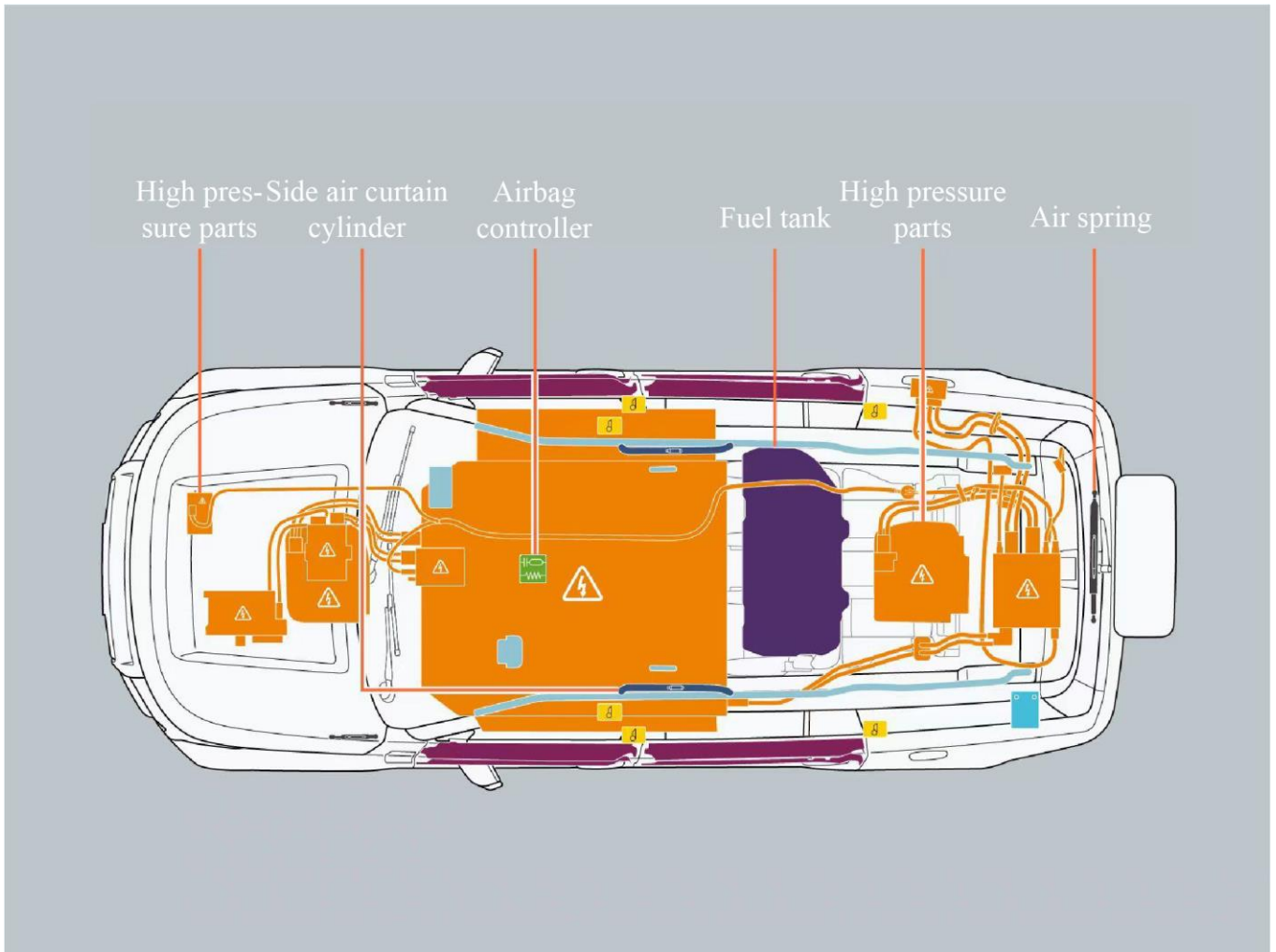

## 9 In case of fault

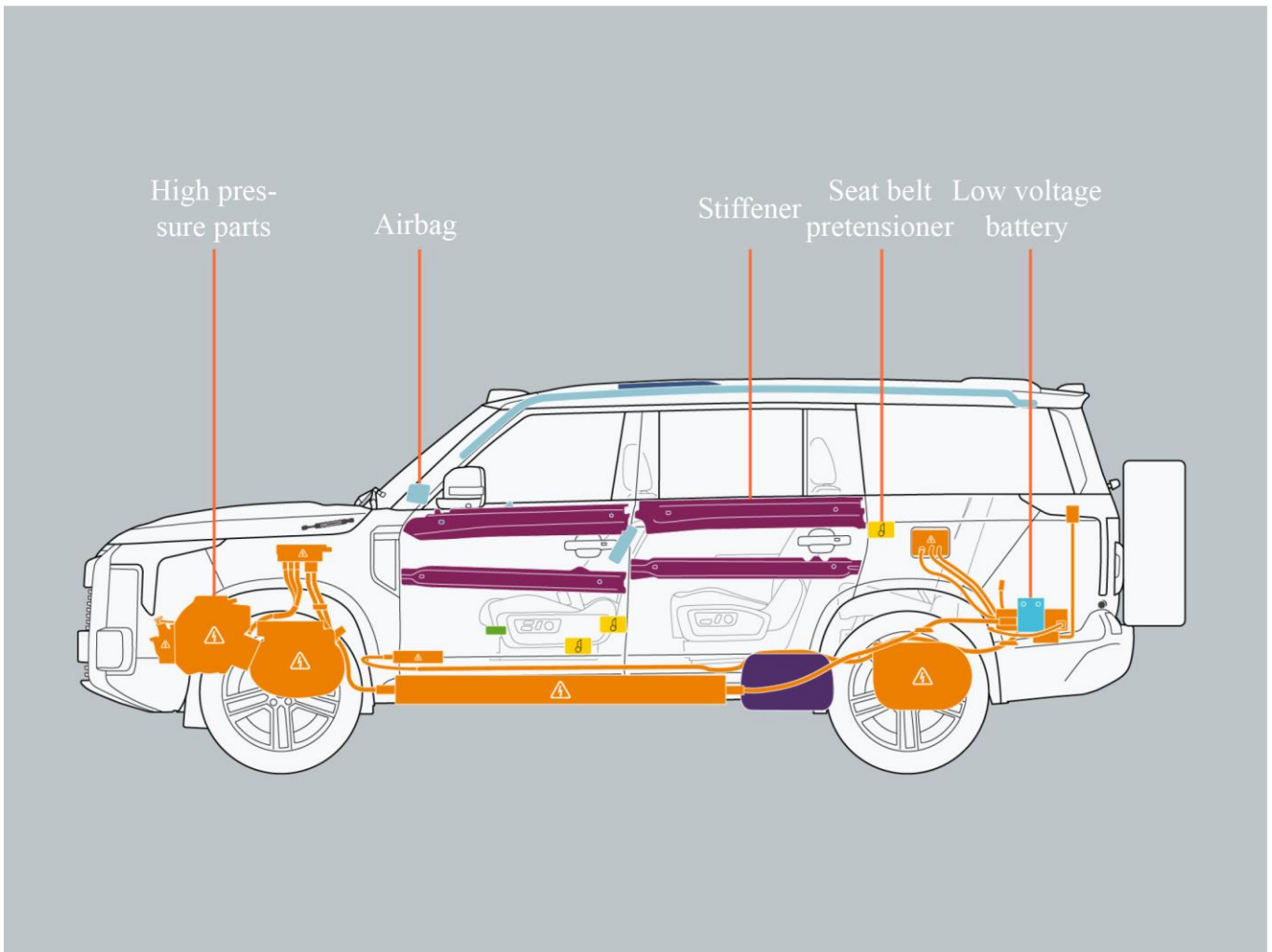

## 10.1 Specification

### 10.1.1 Maintenance data (fuel, oil, etc.)

#### I. Fuel

Item	Parameter
Fuel type	Unleaded gasoline only
Octane number	RON95 # and above
Fuel tank capacity	70L

#### Warning

- Do not use substandard fuel to avoid damaging the range extender. If you accidentally add fuel that does not meet the standards, please do not start the vehicle and contact ROX Service Center immediately.

#### II. Engine oil

Item	Parameter
Engine oil type	ACEAC2/SAE0W-30

#### III. Refrigerant

Item	Parameter
Refrigerant type	R134a
Filling volume	1,100 g±25 g

#### IV. Brake fluid

Item	Parameter
Brake fluid type	DOT4
Filling volume	Fill to close to the MAX line (approx. 0.85 L)

# 10 Vehicle specification

## 10.2 Main dimension parameters of vehicle

### 10.2.1 Front and back of vehicle

I. Front and back of vehicle

1. Model with a spare tire

S/N	Item	Parameter
1	Vehicle height	1,869mm
2	Front tread	1,692mm
3	Vehicle width	1,980mm
4	Rear track	1,701mm
5	Minimum ground clearance	205mm

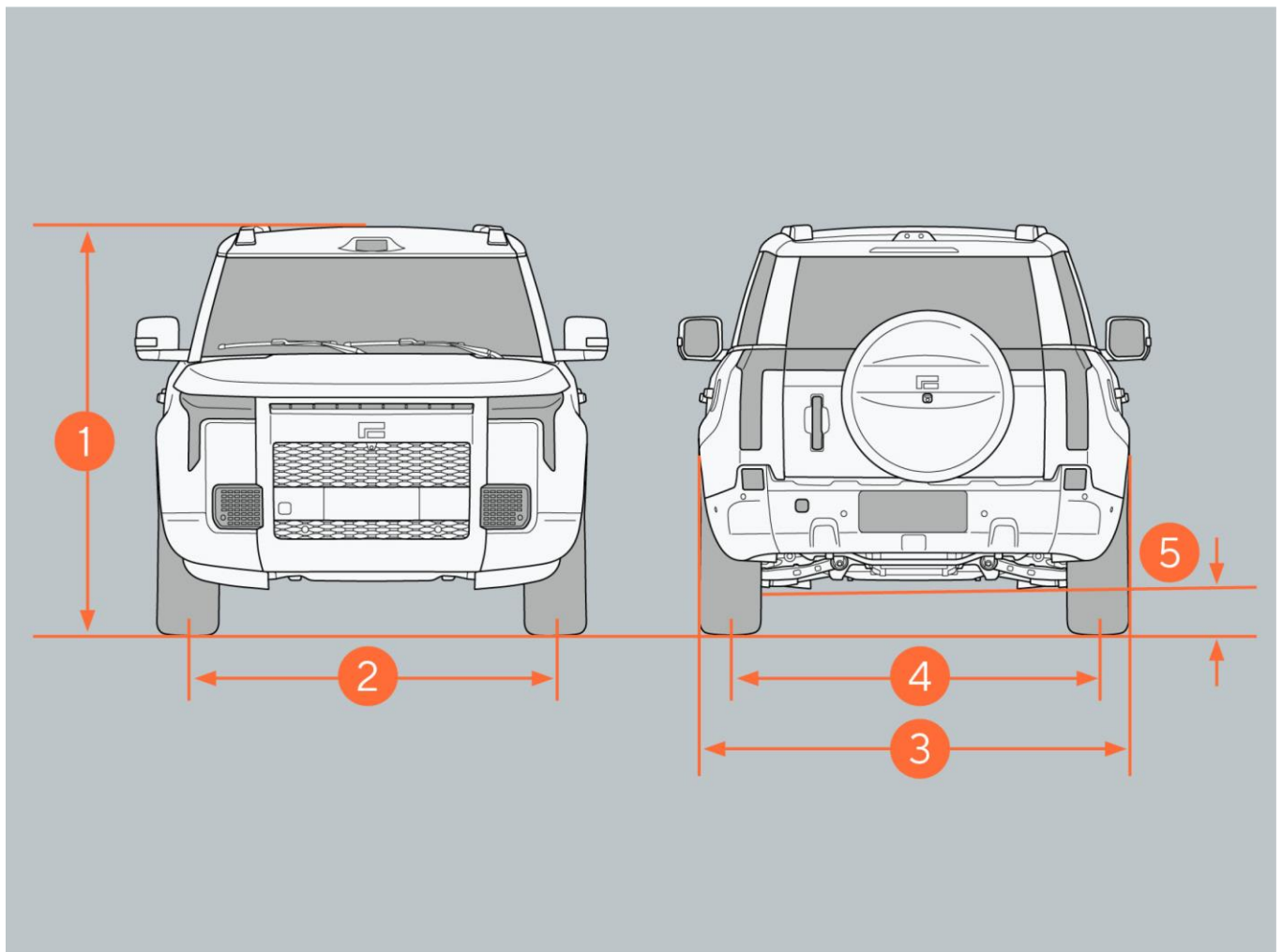

# 10 Vehicle specification

## 2. Model without a spare tire

S/N	Item	Parameter
1	Vehicle height	1,869mm
2	Front tread	1,692mm
3	Vehicle width	1,980mm
4	Rear track	1,701mm
5	Minimum ground clearance	205mm

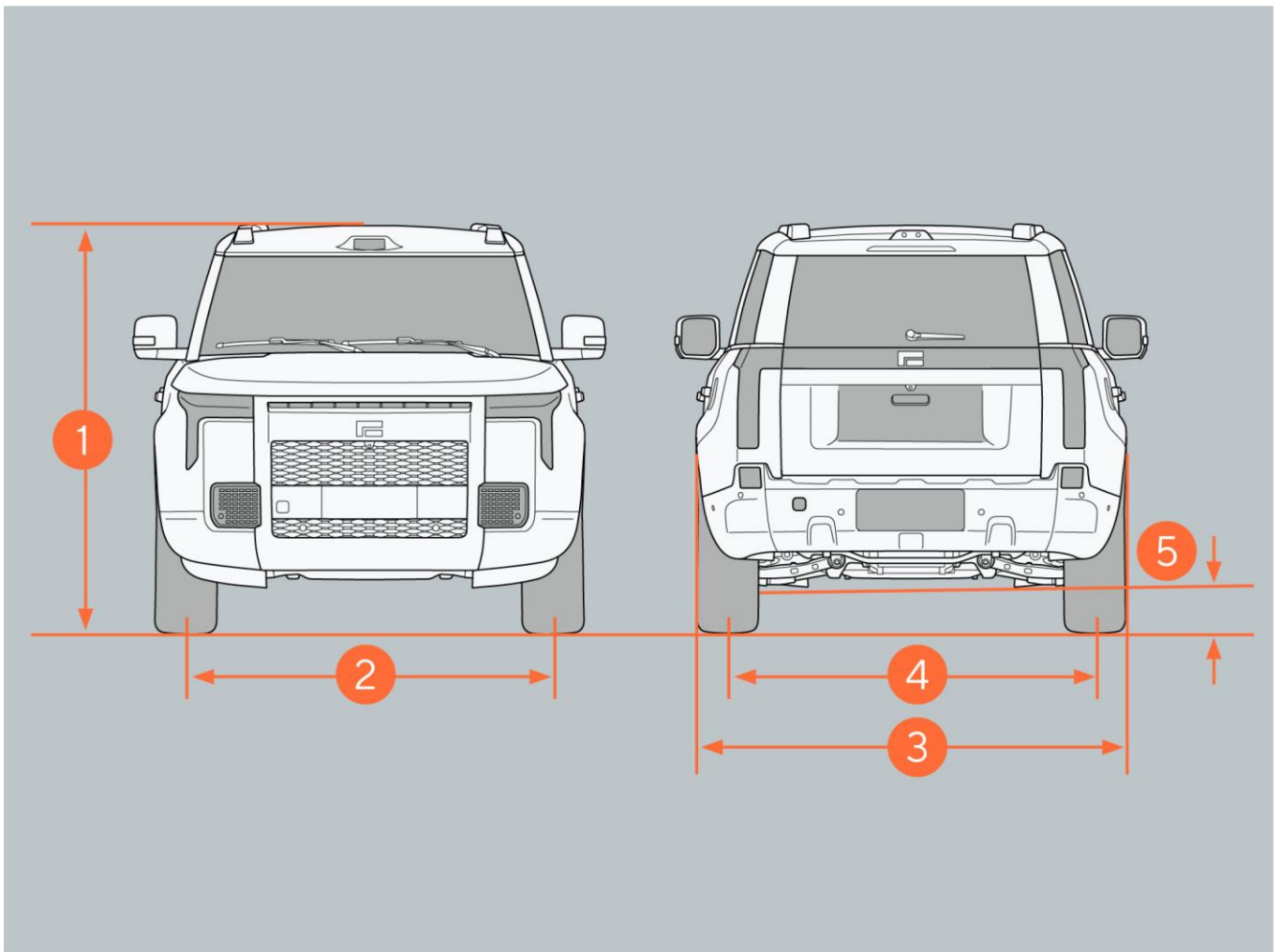



# 10 Vehicle specification

## 10.2.2 Vehicle side

I. Model with a spare tire

1. Model with a spare tire

S/N	Item	Parameter
1	Vehicle length	5,295mm
2	Wheelbase	3,010mm
3	Front overhang	9,65mm
4	Rear overhang	1,320mm
5	Approach angle	$\geq 22^\circ$
6	Departure angle	$\geq 25^\circ$

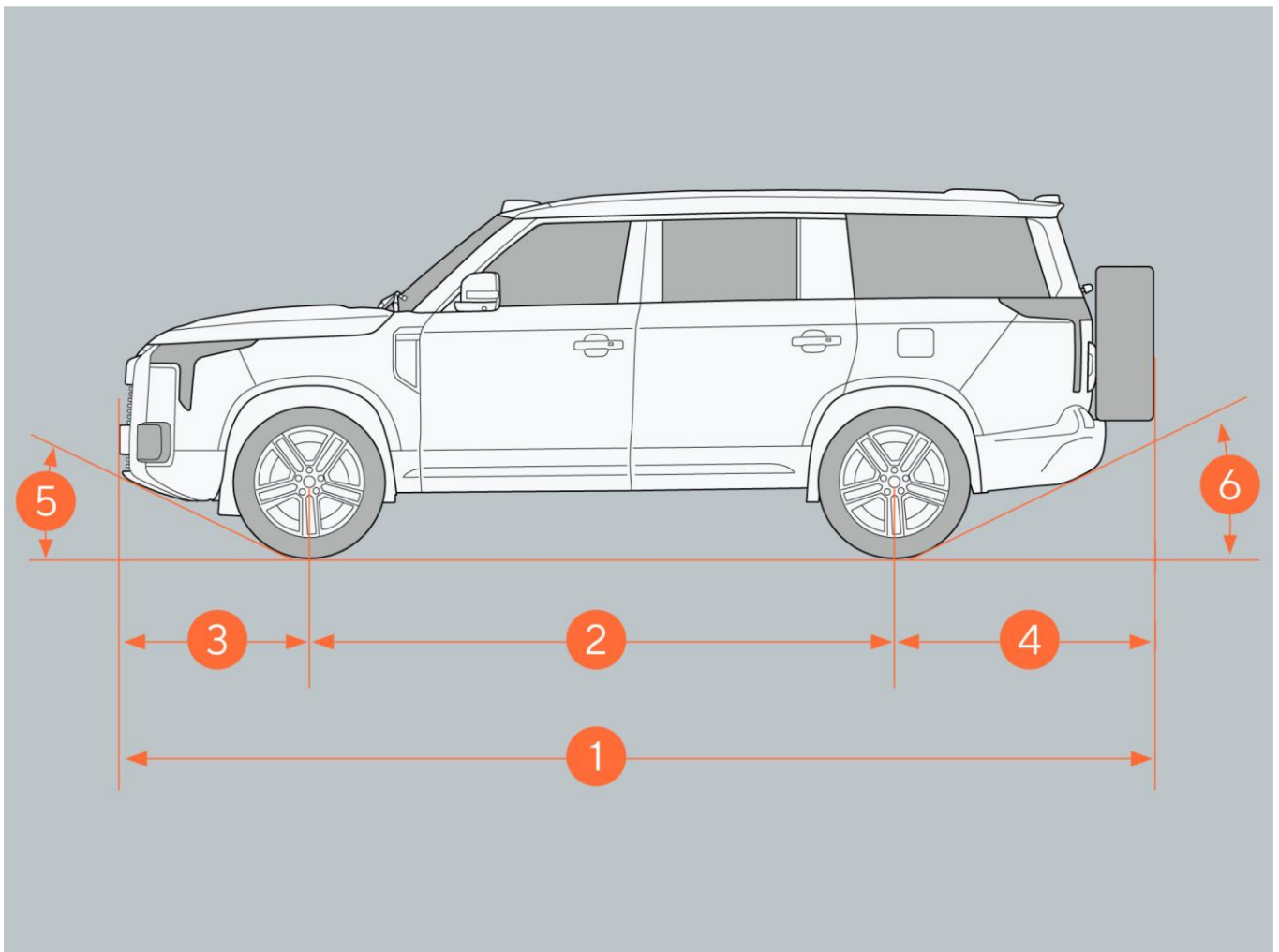

# 10 Vehicle specification

## 2. Model without a spare tire

S/N	Item	Parameter
1	Vehicle length	5,050mm
2	Wheelbase	3,010mm
3	Front overhang	965mm
4	Rear overhang	1,075mm
5	Approach angle	$\geq 22^\circ$
6	Departure angle	$\geq 25^\circ$

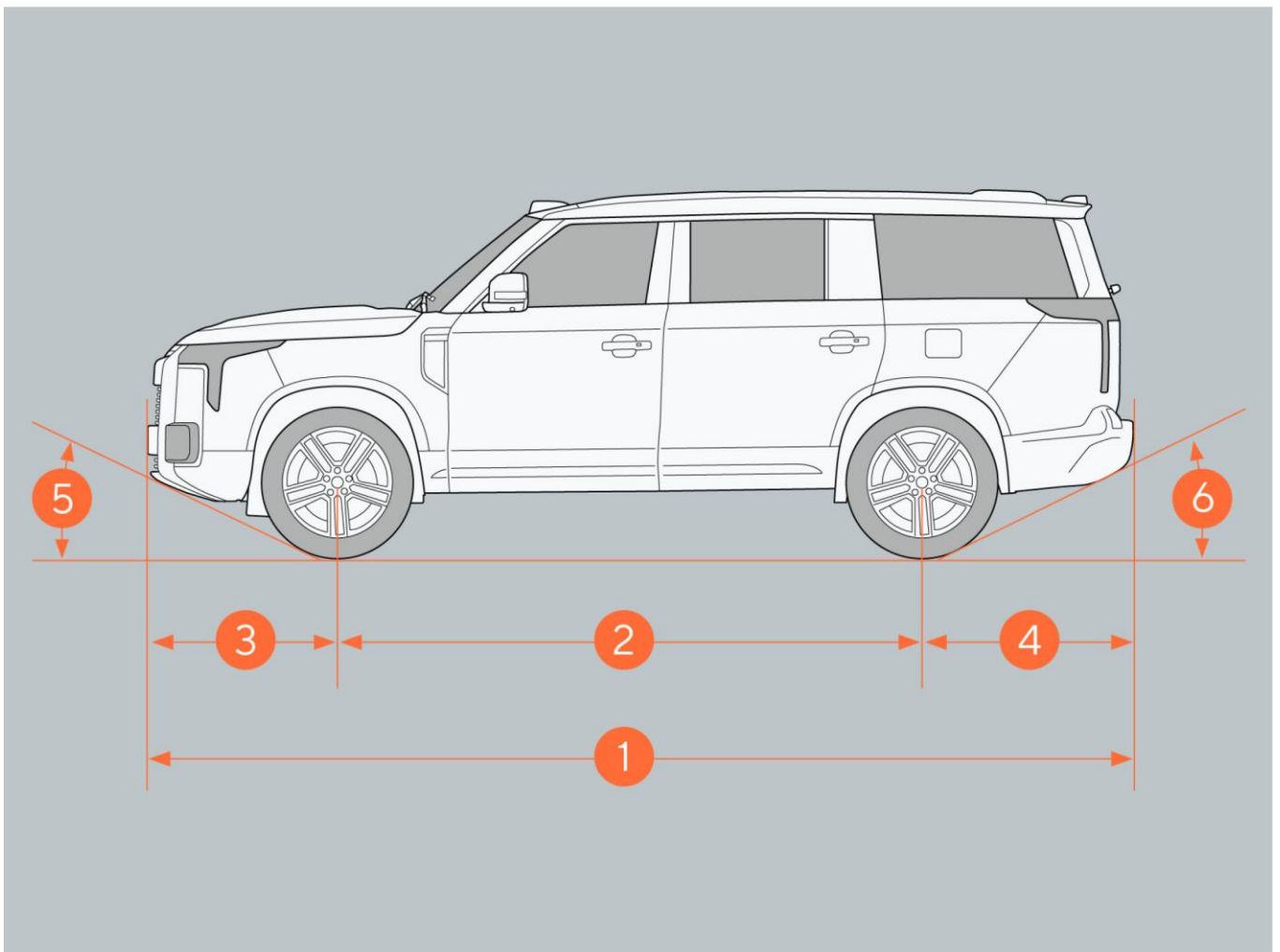

Note: The above dimensions are the measured values at curb weight.

# 10 Vehicle specification

## 10.3 Vehicle technical performance parameters

### 10.3.1 Vehicle mass parameters

Item	Parameter	
	All models with spare tire or aviation seat	All models without spare tire or aviation seat
Number of passengers	6-7 persons	7 persons
Curb mass	2,660 kg	2,580 kg
Front axle load at curb weight	1,295 kg	1,285 kg
Rear axle load at curb weight	1,365 kg	1,295 kg
Max. allowable front axle load	1,393 kg	1,393 kg
Max. allowable rear axle load	1,797 kg	1,797 kg
Max. allowable total mass	3,189 kg	3,189 kg

### 10.3.2 Power parameter

Item	Parameter
Max. speed	190km/h
Maximum grade ability	45°

### 10.3.3 Energy economy parameter

Item	Parameter
Fuel consumption	Refer to Vehicle energy consumption label
Power consumption	Refer to Vehicle energy consumption label
Electric energy equivalent fuel consumption	Refer to Vehicle energy consumption label
Fuel consumption in minimum charge state	Refer to Vehicle energy consumption label

### 10.3.4 Vehicle model

Item	Parameter
Vehicle model	BAW*****

#### Tip

- Each \* represents a number or a letter, please refer to the real car.

### 10.3.5 Drive type

Item	Parameter
Drive type	Front and rear dual motor four-wheel drive

## 10.4 Assembly technical parameters

### 10.4.1 Range extender (engine) specifications and parameter

Item	Parameter
Model	B15F
Number of cylinders	4-cylinder
Bore x stroke	74.5 mm×85.8 mm
Displacement	1.496L
Compression ratio	12.5: 1
Max. net power/speed	110 kW/4,800 rpm
Max. net torque/speed	240 Nm/2,250 rpm ~ 4,000 rpm

### 10.4.2 Tire and hub parameters

Item	Parameter	
	Model with a spare tire	Model without a spare tire
Tire specification	275/45R21110Y	275/45R21110Y
	265/50R20111T	265/50R20111T
Wheel hub specifications	R21X9.0j	R21X9.0j
	R20X8.5j	R20X8.5j
Wheel hub bolt torque	160±16 Nm	160±16 Nm
Vehicle dynamic balancing requirements	Residual dynamic unbalance within 5g on one side	Residual dynamic unbalance within 5g on one side

#### Tip

The tire pressure label is located on the rim of the driver's door, and the tire pressure shown on the label is the cold tire pressure value.

### 10.4.3 Four-wheel alignment

#### I. Front wheel

Parameter Name	Parameter value
Front wheel single-side toe-in	0.2°±0.1°
Front wheel total toe-in	0.4°±0.2°
Front wheel camber	-0.4°±0.5°
Front wheel camber difference	0.5°

# 10 Vehicle specification

## II. Rear wheel

Parameter Name	Parameter value
Single-side toe-in	0.1°±0.1°
Total toe-in	0.2°±0.2°
Camber	-1.2°±0.5°
Camber difference	0.5°

## 10.4.4 Drive motor performance parameters

### I. Front drive motor performance parameters

Item	Parameter
Rated power	66 kW
Rated speed	4,800 rpm
Rated torque	131 Nm
Peak power	150 kW
Peak speed	16,000 rpm
Peak torque	340 Nm

### II. Rear drive motor performance parameters

Item	Parameter
Rated power	80 kW
Rated speed	4,365 rpm
Rated torque	175 Nm
Peak power	200 kW
Peak speed	16,000 rpm
Peak torque	400 Nm

## 10.4.5 Power battery parameter

Item	Parameter
Battery type	Ternary lithium-ion battery
Battery rated voltage	352.3 V
Battery rated capacity	159 Ah
Battery rated energy	56.01 kWh

## 10.4.6 Brake system parameters

Brake system Parameters	
Item	Parameter

## 10 Vehicle specification

Standard thickness of front brake disc	32 mm
Min. thickness of front brake disc	29 mm
Standard thickness of front brake pad	8.5 mm
Min. thickness of front brake pad	2 mm
Standard thickness of rear brake disc	24 mm
Min. thickness of rear brake disc	21 mm
Standard thickness of rear brake pad	8 mm
Min. thickness of rear brake pad	2 mm
Brake pedal free travel	7~10 mm

# 10 Vehicle specification

## 10.5 Vehicle identification information

### 10.5.1 Vehicle identification number (VIN)

Vehicle identification number (VIN)

The VIN is the legal identification number of the vehicle, which is unique and is engraved at the following locations:

- Left front of the instrument panel.

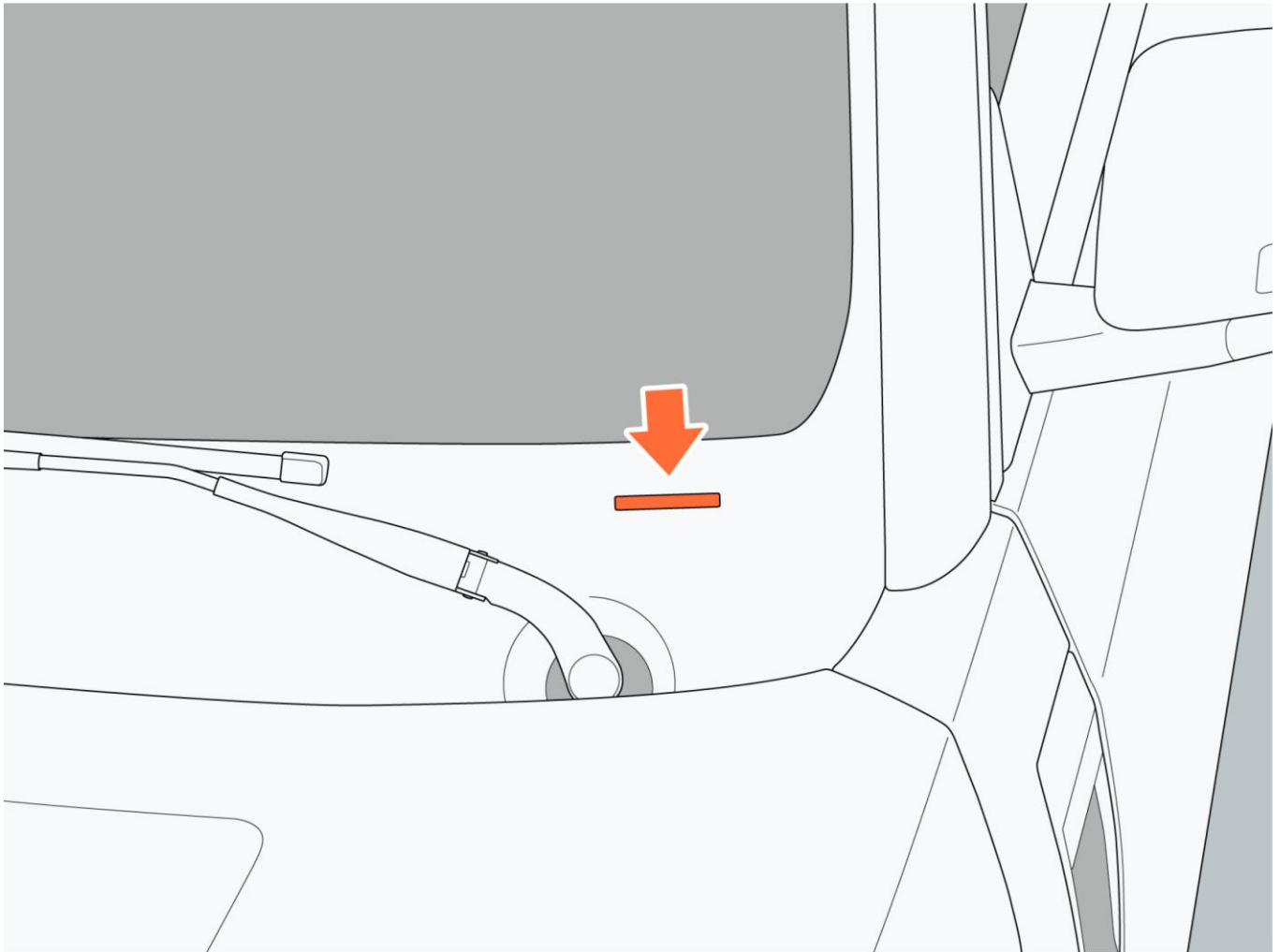

## 10.5.2 Range extender (engine) ID code

The range extender (engine) identification code is printed on the cylinder block.

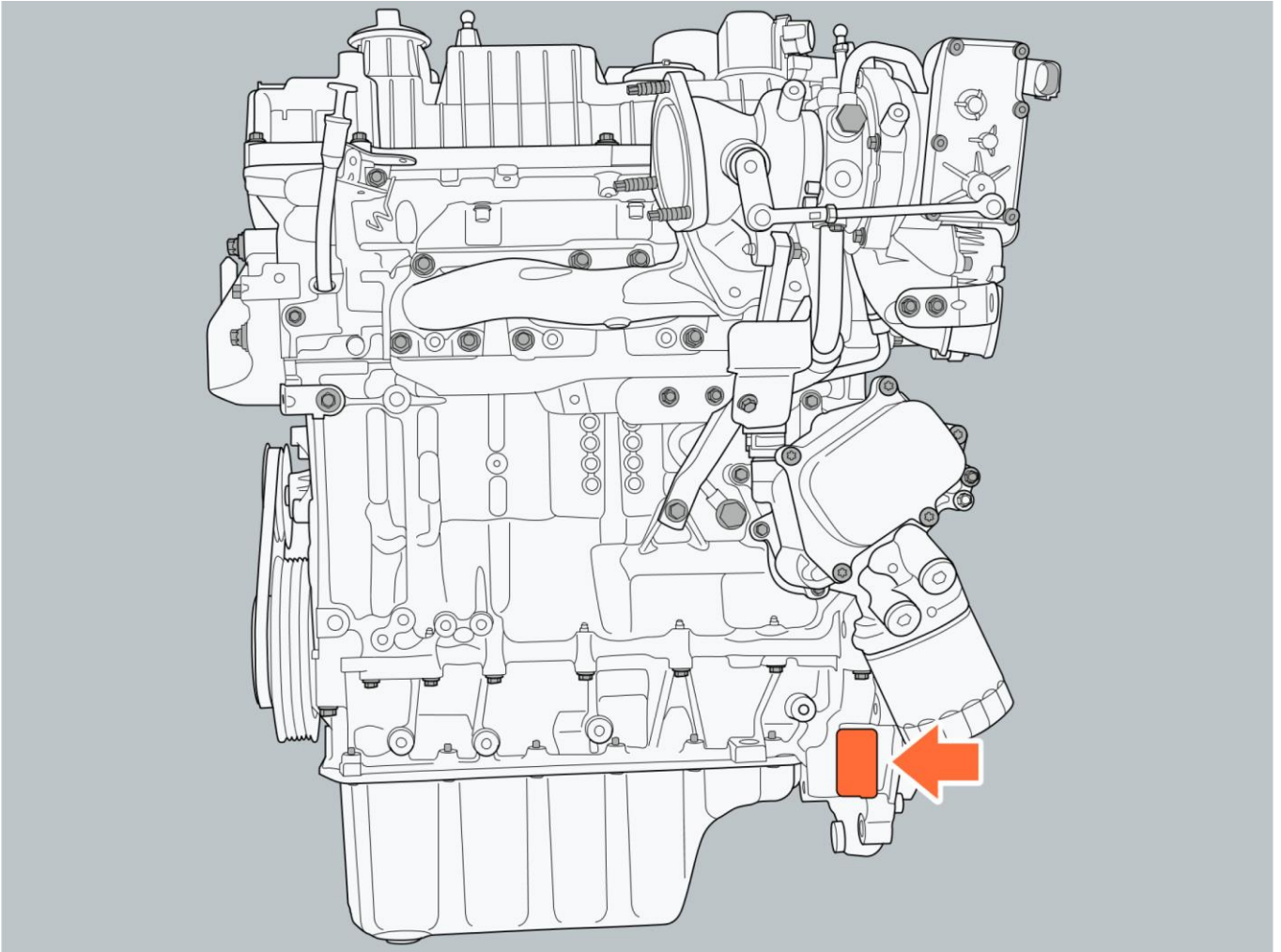



# 10 Vehicle specification

## 10.5.3 Drive motor identification code

### I. Front drive motor

S/N	Item
1	Motor identification code
2	Motor stamping

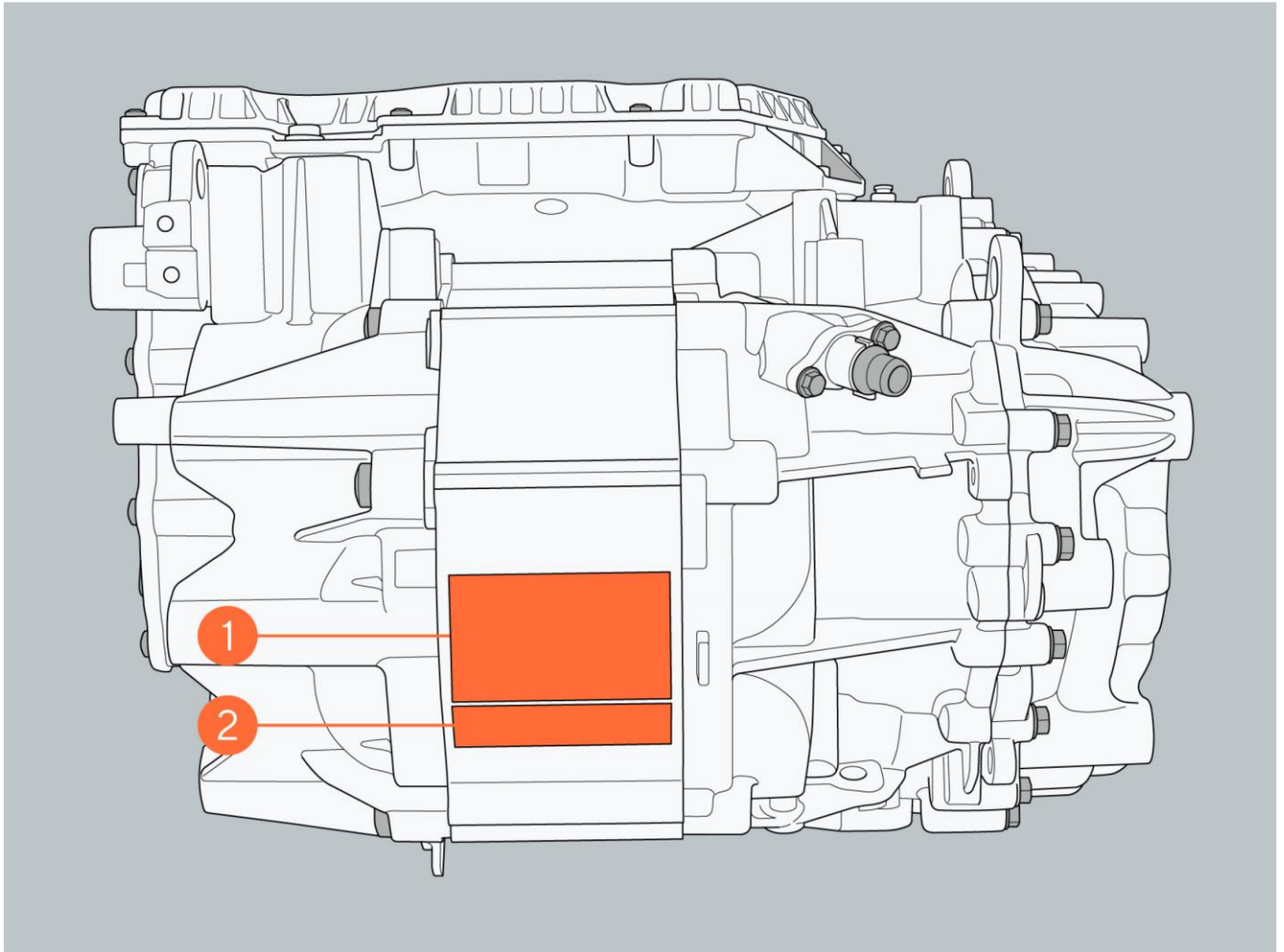

# 10 Vehicle specification

## II. Rear drive motor

S/N	Item
1	Motor identification code
2	Motor stamping

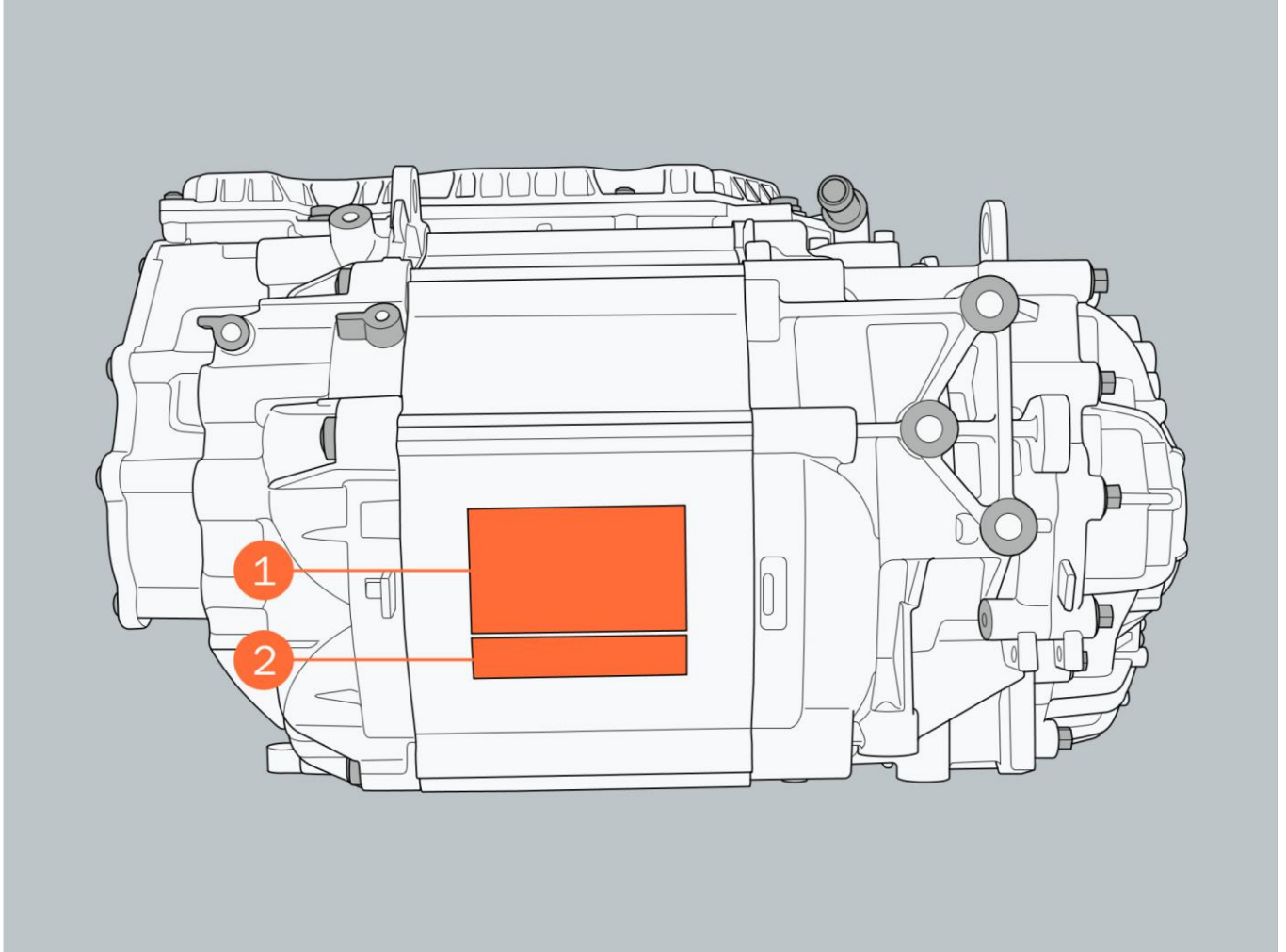

# 10 Vehicle specification

## 10.5.4 Microwave window

### Microwave window

There is a microwave window on the windshield, which can be used to paste electronic label.

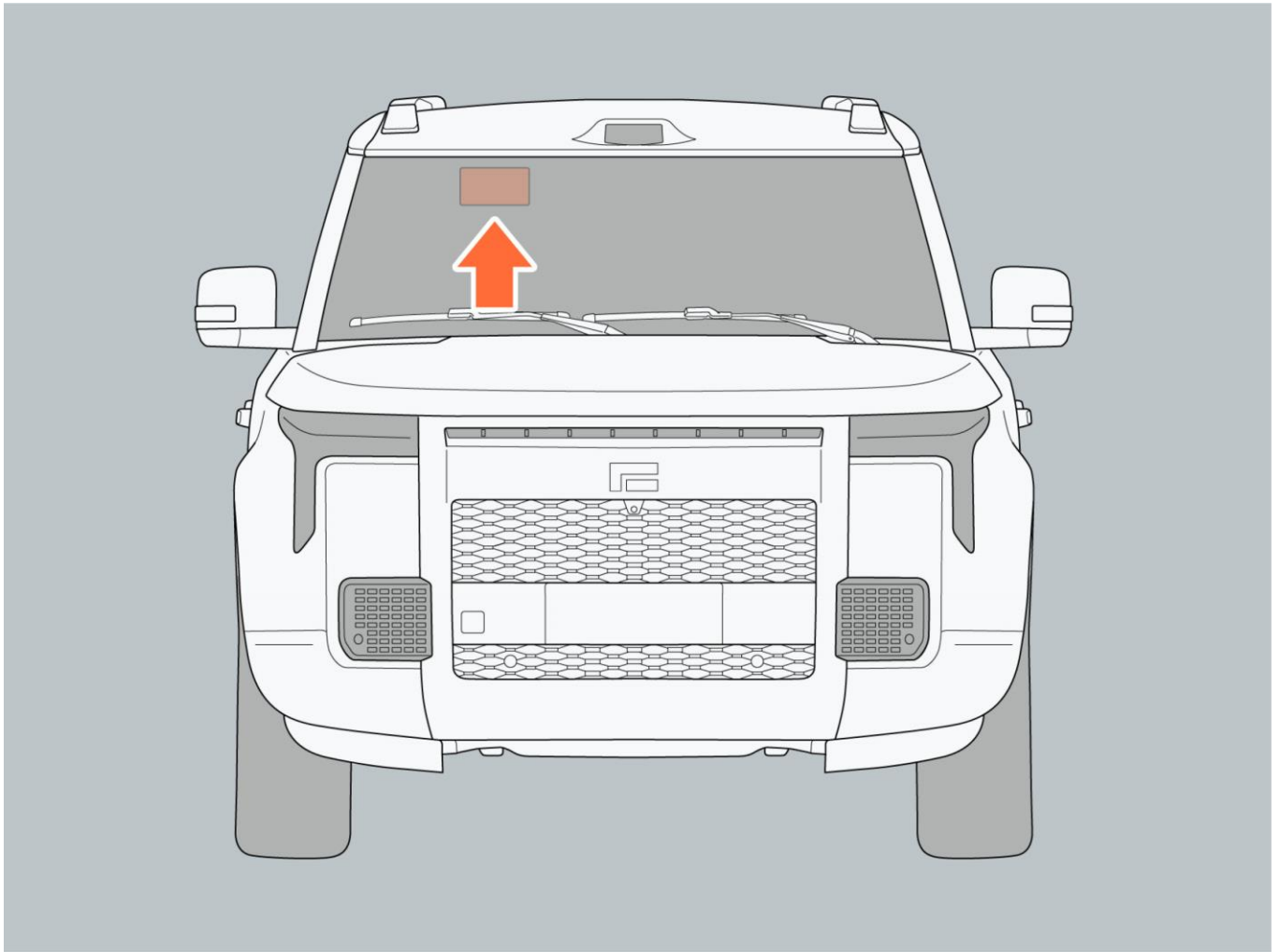

## 10.5.5 Ex-work nameplate

### Ex-work nameplate

The ex-work nameplate is located at the lower end of the B-pillar on the passenger side, which is marked with the vehicle model, VIN and other information.

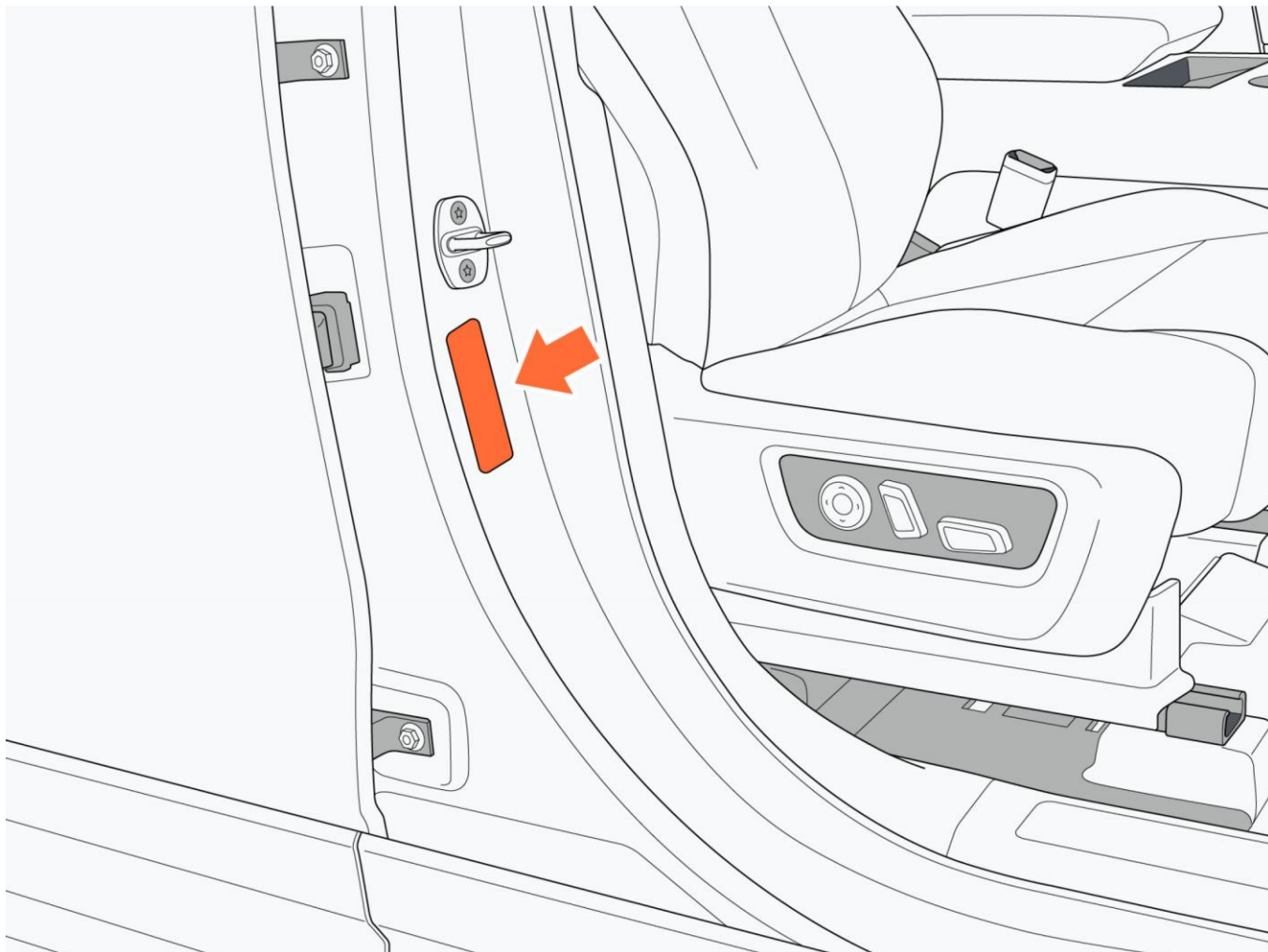

# 10 Vehicle specification

## 10.5.6 Diagnostic interface

The diagnostic interface is located on the left side of the instrument panel, above the brake pedal, which is used to read vehicle information.

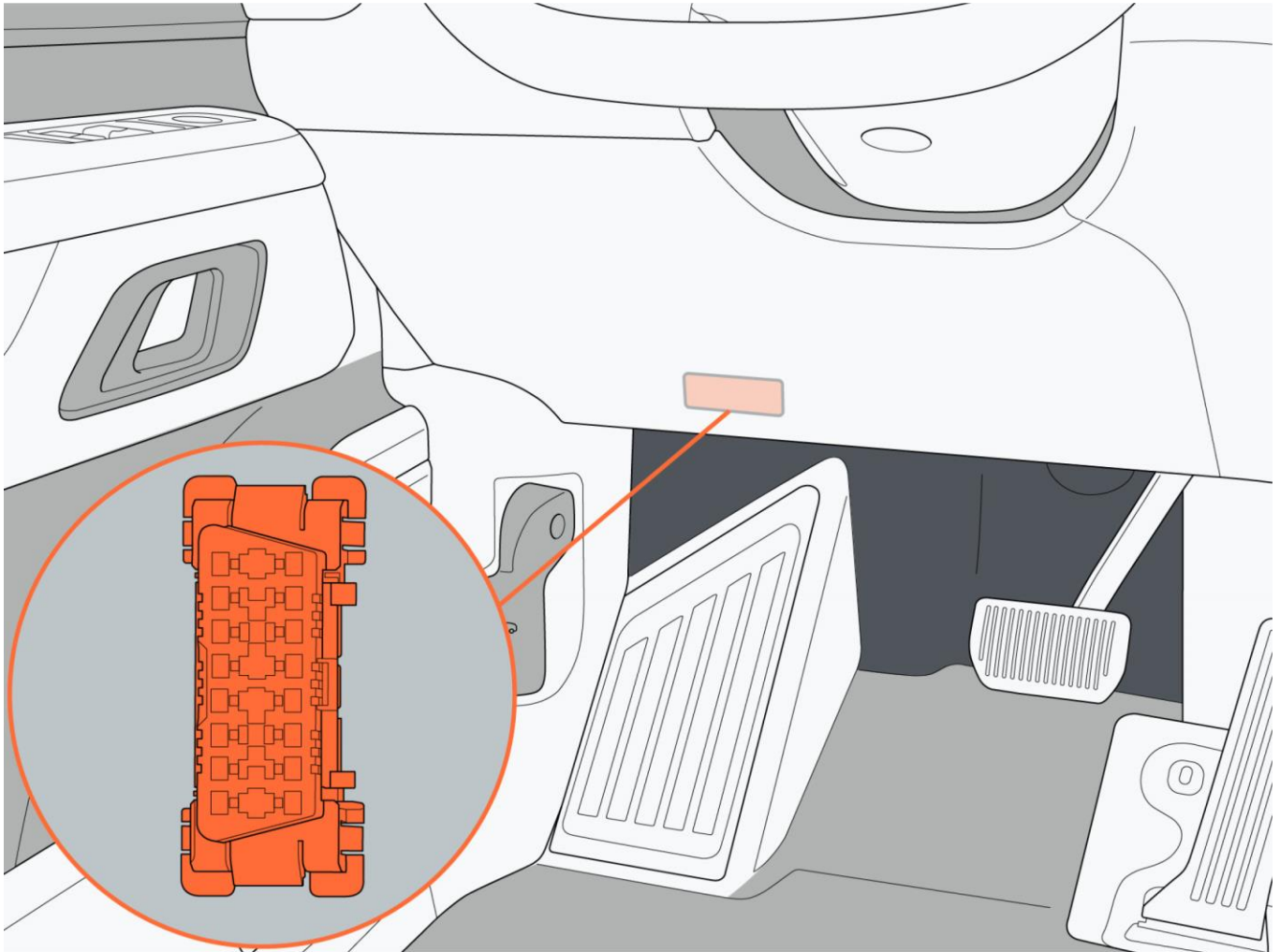

## 10.5.7 Warning and indication label

I. Engine compartment safety warning label

 <b>CAUTION</b> تنبيهات <b>ВНИМАНИЕ</b> 		
 	<b>Refrigerant</b> سائل تبريد Тип хладагента	<b>R134a</b>
	<b>Charge level</b> كمية التحميلة Заправка хладагента	<b>(1100±25)g</b>

# 11 Warranty Manual

## 11.1 Warranty scope

### 11.1.1 Warranty scope

- During the warranty period of ROX 01, if the vehicle is damaged due to the design, manufacture, assembly or raw material defects of the product, the local service center will provide the warranty service and bear the expenses.
- During the warranty period of the power battery, if the capacity of the power battery decreases below 70%, the local service center will provide free repair or replacement of the power battery for the user.

## 11.2 Warranty period

### 11.2.1 Vehicle Warranty period of whole vehicle

The warranty period of the whole vehicle and related parts is as follows:

Classification	Types and scope of parts	Warranty period
Whole vehicle	The whole vehicle and the following unspecified parts	5 years or 100,000km
Three-electric	Power battery, driving motor and its controller	8 years or 160,000km
Key parts	Range extender (engine), generator	5 years or 100,000km
Consumable parts	Air conditioning filter	10,000km
	Wiper blade	10,000km
	Brake pad	20,000km
	Tire	10,000km
	Battery (12V)	4 years or 80,000km
	Remote control battery	20,000km
	Bulb	20,000km
	Fuses and ordinary relays (excluding integrated control units)	20,000km

	Oil filter	10,000km
	Air filter	10,000km
	Spark plug	20,000km

Explain:

- The warranty period in the table shall be based on the time and mileage whichever comes first.
- For parts, accessories or fine products whose warranty period is otherwise agreed with users, the agreed warranty period shall prevail..

## 11.2.2 Special explanation on the warranty period

The work completed by fulfilling the warranty responsibility shall not extend the warranty period of the product. During the warranty period, parts, accessories or fine products that are replaced on the vehicle for free shall have the same warranty period as the remaining warranty period of the replaced parts, accessories or fine products, and will end with the end of the remaining warranty period of the replaced parts, accessories or fine products. When the ownership of the vehicle changes, the warranty responsibility of the vehicle shall not be terminated, and the vehicle shall still maintain the warranty period specified in this warranty clause.

## 11.3 Warranty disclaimer

### 11.3.1 Warranty disclaimer

During the vehicle warranty period, if there are product quality issues with the Household ROX 01, we can assist the user in handling replacement matters, except for the following situations:

- Normal component wear or aging, such as normal wear and tear of tires, wiper blades, deformation or fading caused by normal aging of rubber, paint, envelope, etc., normal attenuation of chemical energy storage devices such as power battery cells, 12V batteries, and remote key batteries.
- Product quality problems occur after the consumable parts exceed the specified warranty period.
- The vehicle purchased by the user has been notified in writing (including but not limited to the user manual, warranty clause, and purchase contract) that there are defects.
- The vehicle is used for rental, online car-hailing, leasing or other operational purposes.
- The vehicle is used for non household purposes and conditions such as competition, off-road race, performances and entertainment, experiment, military action, requisition, etc.
- Damage to the vehicle caused by self modification, adjustment, or disassembly by the user.
- Malfunctions caused by the use of automotive components, oils, and accessories that do not meet the original factory standards, or by the use of products that may damage the vehicle.



# 11 Warranty Manual

- Power battery failure or damage caused by immersing any part of the power battery in water or other liquids.
- Power battery failure or damage caused by the use of non-standard or incompatible charging equipment, or failure to follow the correct charging operation process.
- Vehicle damage caused by improper handling by users due to product quality issues.
- Damage caused by failure to use, maintain, and repair the product correctly in accordance with the usage requirements and maintenance specifications in this manual.
- Failure or damage of the power battery caused by long-term storage of the vehicle for more than 3 months without regular maintenance of the power battery.
- Vehicle damage caused by external environmental factors, such as corrosive chemicals in the air, radioactive dust, tree sap, animal and insect excrement, seawater, acid rain, stones, industrial smoke/dust, hail, earthquake, flood, storm, lightning, etc.
- Vehicle damage caused by incorrect chemical treatment, such as vehicle damage or corrosion caused by improper use of chemicals or sealants.
- Vehicle damage caused by theft, car accidents, traffic accidents, overloading, wading, destruction, riots, explosions, and impact of foreign objects or intentional actions.
- Other damages caused by force majeure, except as mentioned above.

# 12 Abbreviations and terminology

## 12.1 Abbreviations and terminology

### 12.1.1 Abbreviations and terminology

Abbreviation	Instruction	Abbreviation	Instruction	Abbreviation	Instruction	Abbreviation	Instruction
A	Ampere	km	Kilometer	m	Meter	MΩ	Megohm
dB	Decibel	km/h	Kilometer/hour	mA	Milliamper e	N	Newton
ft	Foot	kPa	Kilopascal	mg	Milligram	Nm	Newton•mete r
g	Gram	kW	Kilowatt	MHz	Megahertz	No.	S/N
gal	Gallon	KΩ	Kiloohm	ml	Milliliter	rpm	Revolutions per minute
Hz	Hertz	lb	Pound	mm	Millimeter	V	Volt
in	Inch	lb-in	Pound-inch	mpg	Miles per gallon	W	Watt
kg	Kilogram	lb-ft	Pound-foot	mph	Miles per hour	ya	Yard
kHz	Kilohertz	L	Liter	mV	Millivolt		

## 12 Abbreviations and terminology

Abbreviation	English full Name	Chinese Name	Abbreviation	English full Name	Chinese Name
ABS	Anti-lock Brake System	防抱死制动系统	DOHC	Double Overhead Camshaft	顶置双凸轮轴
A/C	Air Conditioning	空调	DTC	Diagnostic Trouble Code	故障代码
AM/FM	Amplitude Modulation/Frequency Modulation	调幅/调频	DVD	Digital Video Disk	DVD
ASR	Acceleration Skid Control System	加速防滑控制系统	EBD	Electric Brake force Distribution	电子制动力分配
AT	Auto Transmission	自动变速器	ECM	Engine Control Module	发动机控制模块
BCM	Body Control Module	车身控制模块	EDS	Electronic Differential System	电子差速锁
CD	Compact Disc	CD	EGR	Exhaust-Gas Recirculation	废弃再循环
CAN	Controller Area Network	控制器局域网	ESP	Electronic Stability Program	电子稳定程序
EOBD	European On Board Diagnostic	欧洲在线诊断	FWD	Front Wheel Drive	前轮驱动
ISO	International Standards Organization	国际标准化组织	LED	Light-Emitting Diode	发光二极管
MP3	MPEG Audio Layer3	MP3	MT	Manual Transmission	手动变速器
GPS	Globe Positioning System	全球定位系统	HVAC	Heating Ventilation Air Conditioning	暖风、通风和空调
OBD-II	On Board Diagnostic II	在线诊断II	OEM	Original Equipment Manufacturer	原始设备制造商

## 12 Abbreviations and terminology

PAM	Parking Aid Module	停车辅助模块	RWD	Rear Wheel Drive	后轮驱动
SAE	Society of Automotive Engineers	美国汽车工程师学会	SFI	Sequential Fuel Injection	顺序燃油喷射
SOHC	Single Overhead Camshaft	单顶置凸轮轴	SRS	Supplemental Restraint System	辅助安全系统
SUV	Sport Utility Vehicle	越野车	TDI	Turbo Direct Injection	涡轮增压直喷
TPMS	Tire Pressure Monitoring System	轮胎压力监控系统	4WD	Four Wheel Drive	4轮驱动
MS-CAN	Middle Speed Controller Area Network	中速控制器局域网			



